

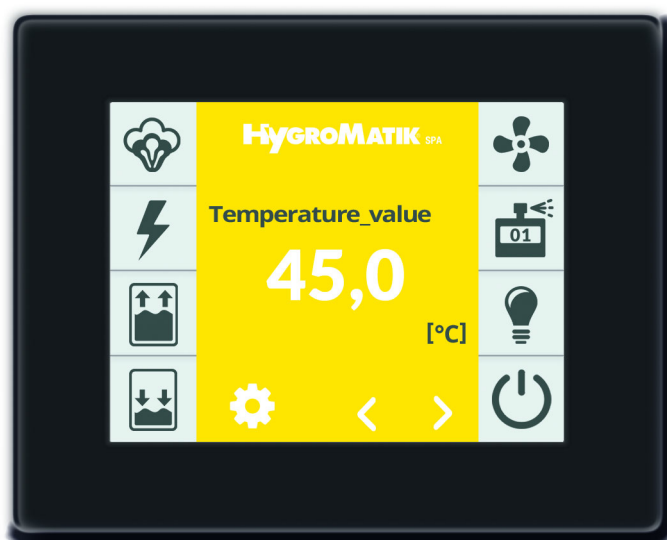

HyGROMATIK® SPA

FlexLine Spa

Control



Manual



FL-TSPA.EN
E-8881168

Certain computer programs contained in this product [or device] were developed by HygroMatik GmbH ("the Work(s)").

Copyright © HygroMatik GmbH [30.08.2021]

FlexLine SPA Control

Validity: This documentation is valid for the control system of the Flexline device series.

All Rights reserved.

Current version of this manual can be found at: www.hygromatik.co.uk

HygroMatik GmbH grants the legal user of this product [or device] the right to use the Work(s) solely within the scope of the legitimate operation of the product [or device]. No other right is granted under this licence. In particular and without prejudice to the generality of the foregoing, the Work(s) may not be used, sold, licensed, transferred, copied or reproduced in whole or in part or in any manner or form other than as expressly granted here without the prior written consent of HygroMatik GmbH.

Information in this manual is subject to change or alteration without prior notice.

The device-specific wiring diagrams are included in the scope of delivery. Please keep them carefully for future use.

▲ WARNING

Risk of electrical shock!

Hazardous electrical high voltage!

All electrical work to be performed by certified expert staff (electricians or expert personnel with equivalent training) only.

1. Introduction	5
1.1 Typographic Distinctions	5
1.2 Documentation	5
1.3 Symbols in Use	5
1.3.1 Specific Symbols related to Safety Instructions	5
1.3.2 General Symbols	5
2. Safety Instructions	7
2.1 Guidelines for Safe Operation	7
2.1.1 Scope	7
2.1.2 Unit control	7
2.1.3 Unit Operation	7
2.1.4 Mounting, dismantling, maintenance and repair of the unit	8
2.1.5 Electrical	8
2.2 Disposal after dismantling	8
3. Overview of the operation and layout of a steam bath	9
3.1 Layout of steam bath (schematic diagram)	10
3.2 Temperature sensor usage	11
3.2.1 Installation of the temperature sensor	11
3.2.2 Connection of the temperature sensor	11
3.3 Steam bath temperature control	11
3.4 Fan control	12
3.4.1 Supply fan	12
3.4.2 Exhaust fan	12
3.5 Sample diagram for temperature profile in steam bath	13
4. Description of control	14
4.1 General description	14
4.2 Layout of control	14
4.3 Mainboard	15
4.3.1 Connections on the mainboard	16
4.4 Expansion board (double cylinder units)	17
4.4.1 Connections on the expansion board	17
4.5 Relay circuit board	18
4.5.1 Connections on the relay board	18
4.6 Electrical connection	19
4.6.1 Connection of control voltage	19
4.6.2 Connection of interlock (safety) system	19
4.6.3 Connection of the temperature sensor(s)	20
4.6.4 Connecting the digital input (DI)	20
4.6.5 Wiring for control signal and safety (interlock) system for multiple units	20
5. The display	21
6. Operation of control	23
6.1 Operation basics	23
6.2 Screen 1 - Commissioning	25

6.2.1 Setting the language	25
6.2.2 Input of date and time of day	25
6.2.3 Control settings	26
6.3 Screen 2 - Main screen	27
6.3.1 Changing the set point temperature	28
6.4 Password entry	29
6.5 Screen 3 - Main menu (user level)	29
6.6 User level submenus	29
6.6.1 Settings submenu	31
6.6.2 Reading values submenu	32
6.6.3 History submenu	34
6.7 Screen 3 - Main menu (operator level)	36
6.8 Operator level submenus	37
6.8.1 Settings submenu	38
6.8.2 Reading values submenu	39
6.8.3 Control submenu	39
6.8.4 Service submenu	40
6.8.5 History submenu	42
6.8.6 Blow-down submenu	43
6.8.7 Fill parameters submenu	43
6.8.8 Functions submenu	44
6.8.9 Communication interface submenu	46
6.8.10 Weekly timer submenu	47
6.8.11 SPA submenu	48
6.8.12 Essence submenu	49
6.8.13 Recording submenu	50
6.8.14 Cylinder extension submenu	52
6.8.15 Relay extension 1 submenu	53
6.8.16 Relay extension 2 submenu	54
7. Faults and service messages	58
7.1 Fault handling	58
7.1.1 Table of fault messages, possible causes and countermeasures	58
7.2 Servicemessages and warnings	65
7.3 Functional fault chart	66
8. Wiring diagrams	70
8.1 FLE - Option 230V	70
8.2 FLE - Option 24V	77
8.3 FLH - Option 230V	80
8.4 FLH - Option 24V	83
8.5 FLP - Option 230V	86
8.6 FLP - Option 24V	89
9. Glossary	92
10. Technical data	97

1. Introduction

Dear Customer,

Thank you for choosing a HygroMatik steam humidifier.

HygroMatik steam humidifiers represent the latest in humidification technology.

In order to operate your HygroMatik steam humidifier safely, properly and efficiently, please read these operating instructions, which are supplemented by other operating instructions for the relevant basic unit.

Employ your steam humidifier only in sound condition and as directed. Consider potential hazards and safety issues and follow all the recommendations in these instructions.

If you have additional questions, please contact your expert dealer.

For all technical questions or spare parts orders, please be prepared to provide unit type and serial number (see name plate on the unit).

1.1 Typographic Distinctions

- Preceded by a bullet: general specifications
- » Preceded by an arrow: procedures for servicing or maintenance which should or must be performed in the indicated order
- ☑ Installation step which must be checked off.

italics Terms used with graphics or drawings

1.2 Documentation

Retention

Please retain these operating instructions in a secure, always accessible location. If the product is resold, turn the documentation over to the new operator. If the documentation is lost, please contact HygroMatik.

Versions in Other Languages

These operating instructions are available in several languages. If interested, please contact HygroMatik or your HygroMatik dealer.

1.3 Symbols in Use

1.3.1 Specific Symbols related to Safety Instructions

According to ANSI Z535.6 the following signal words are used within this document:

▲ DANGER

DANGER indicates a hazardous situation which, if not avoided, will result in death or serious injury.

▲ WARNING

WARNING indicates a hazardous situation which, if not avoided, could result in death or serious injury.

▲ CAUTION

CAUTION indicates a hazardous situation which, if not avoided, could result in minor or moderate injury.

NOTICE

NOTICE is used to address practices not related to physical injury.

1.3.2 General Symbols

Please note

This symbol is used whenever a situation requires special attention beyond the scope of safety instructions.

Intended Use

The control described is an integral part of a HygroMatik steam humidifier. Use for other applications is not permitted. All instructions on intended use, which are given in connection with the basic device, apply.

Proper usage also comprises the adherence to the conditions specified by HygroMatik for:

- installation
- dismantling
- reassembly
- commissioning
- operation
- maintenance
- disposal

Only qualified and authorised personnel may operate the unit. Persons transporting or working on the unit must have read and understood the corresponding parts of the Operation and Maintenance Instructions and especially the chapter 2. „Safety Notes“. Additionally, operating personnel must be informed of any possible dangers. You should place a copy of the Operation and Maintenance Instructions at the unit's operational location (or near the unit).

By construction, HygroMatik steam humidifiers are not qualified for exterior application.

▲ WARNING

Risk of scalding!

Steam with a temperature of up to 100 °C is produced.

Do not inhale steam directly!

2. Safety Instructions

These safety instructions are required by law. They promote workplace safety and accident prevention.

2.1 Guidelines for Safe Operation

2.1.1 Scope

Comply with the accident prevention regulation „DGUV Regulation 3“ to prevent injury to yourself and others. Beyond that, national regulations apply without restrictions. This way you can protect yourself and others from harm.

2.1.2 Unit control

Do not perform any work which compromises the safety of the unit. Obey all safety instructions and warnings present on the unit.

In case of a malfunction or electrical power disruption, switch off the unit immediately and prevent a restart. Repair malfunctions promptly.

⚠ WARNING

Restricted use.

IEC 60335-1 stipulates as follows:

This device may be used by children of eight years of age and above as well as by persons with reduced physical, sensory or mental capabilities or lack of experience and knowledge so long as they are supervised or have been instructed regarding the safe use of the device and understand the hazards that may result from it. Cleaning and user maintenance of the unit must not be undertaken by children without supervision.

2.1.3 Unit Operation

⚠ WARNING

Risk of scalding!

Uncontrolled hot steam escape in case of leaking or defective components possible. Switch off unit immediately.

⚠ WARNING

For Ministeam devices applies:

Risk of scalding!

No persons may be under the cloud of steam blowing out (at a distance of approx. 1 m/40 inch in the direction of blowing out and 0.5 m/20 inch on both sides of the device).

NOTICE

Risk of material damage!

- The unit may be damaged if switched on repeatedly following a malfunction without prior repair. Rectify defects immediately!
- The unit must not be operated on a DC power supply.
- The unit may only be used connected to a steam pipe that safely transports the steam (not valid for MiniSteam units).
- Regularly check that all safety and monitoring devices are functioning normally. Do not remove or disable safety devices.
- Steam operation is only allowed when the unit cover is closed.

NOTICE

Water leaks caused by defective connections or malfunctions are possible.

Water is constantly and automatically filled and drained in the humidifier. Connections and water-carrying components must be checked regularly for correct operation.

2.1.4 Mounting, dismantling, maintenance and repair of the unit

NOTICE

The HygroMatik steam humidifier is IP20 protected. Make sure that the unit is not object to dripping water in the mounting location.

Installing a humidifier in a room without water discharge requires safety devices to protect against water leakages.

- Use genuine spare parts only
- After any repair work, have qualified personnel check the safe operation of the unit
- Attaching or installing of **additional components** is permitted only with the **written consent** of the manufacturer

NOTICE

Do not install HygroMatik steam generators above electrical equipment such as fuse boxes, electrical appliances, etc. In the case of a leakage, leaking water can damage the underlying electrical equipment

2.1.5 Electrical

⚠ WARNING

Risk of electrical shock!

Hazardous electrical voltage!

Any work on the electrical system to be performed by certified expert staff (electricians or expert personnel with comparable training) only.

Steam operation may only be started when the unit cover is closed.

During maintenance or installation work, the device must be disconnected from the power supply and secured against being switched on again. The absence of voltage must be ensured by a measurement.

Leaks can cause leakage currents. Observe safety regulations on working with voltage parts (applies to electrode steam humidifiers).

After electrical installation or repair work, test all safety mechanisms (such as grounding resistance).

NOTICE

Use only original fuses with the appropriate amperage rating.

Regularly check the unit's electrical equipment. Promptly repair any damage such as loose connections or burned wiring.

Responsibility for intrinsically safe installation of the HygroMatik steam humidifiers is incumbent on the installing specialist company.

2.2 Disposal after dismantling

The humidifier is made up of metal parts and plastic parts. In reference to European Union directive 2012/19/EU issued on 4 July 2012 and the related national legislation, please note that:

The components of the electrical and electronic devices must not be disposed of as municipal waste, and therefore the method of waste separation must be applied. The public or private waste collection systems defined by local legislation must be used.

NOTICE

The operator is responsible for the disposal of unit components as required by law.

3. Overview of the operation and layout of a steam bath

The HygroMatik steam generator provides the steam bath with the steam required for operation. The temperature measured in the steam bath is the only control variable used to control the steam production. When standard settings are used, the steam bath reaches approx. 45 °C at 100% humidity. One or, if required, two supply fans introduce fresh air to the steam bath, one or two exhaust fans extract warm air from the steam bath to ensure a continuous supply of steam and stable temperature control. The steam generator can control up to 4 essence injectors.

Heating-up phase:

Steam is supplied to the steam bath, which is still cold. As a result, the relative humidity increases first to 100%, while the temperature remains almost constant. A further supply of steam then increases the temperature; the relative humidity remains at 100%.

Operational phase:

When the set point temperature value + switch-off temperature difference has been reached, steam production is interrupted. If the steam bath temperature sinks below the adjustable set point temperature, steam is again introduced into the cabin.

Please note

Controls for lights, fans and essences are optional accessories. The HygroMatik steam bath functions are optionally available in 24 V or 230 V versions.

⚠ WARNING

There is a danger of electric shock due in case of non-observance!

Only safety extra-low voltage (24 V) may be used in the steam cabin for fans and lights.

⚠ WARNING

Risk of scalding!

- Ensure that there is no skin contact with the hot steam in the direct area of steam supply to the cabin.
- Ensure that possible condensate from the point of steam feed into the cabin cannot drip on the skin.

3.1 Layout of steam bath (schematic diagram)

Position	Designation
1	Steam generator
2	Essence peristaltic pump
3	Essence container
4	Essence line to steam hose
5	T-piece for essence injection into steam hose
6	Steam hose
7	Steam manifold in steam bath
8	Supply fan
9	Temperature sensor
10	Exhaust fan
11	Cabin light

Please note

The following figure shows a simplified diagram of a steam bath - it is not an installation instruction!

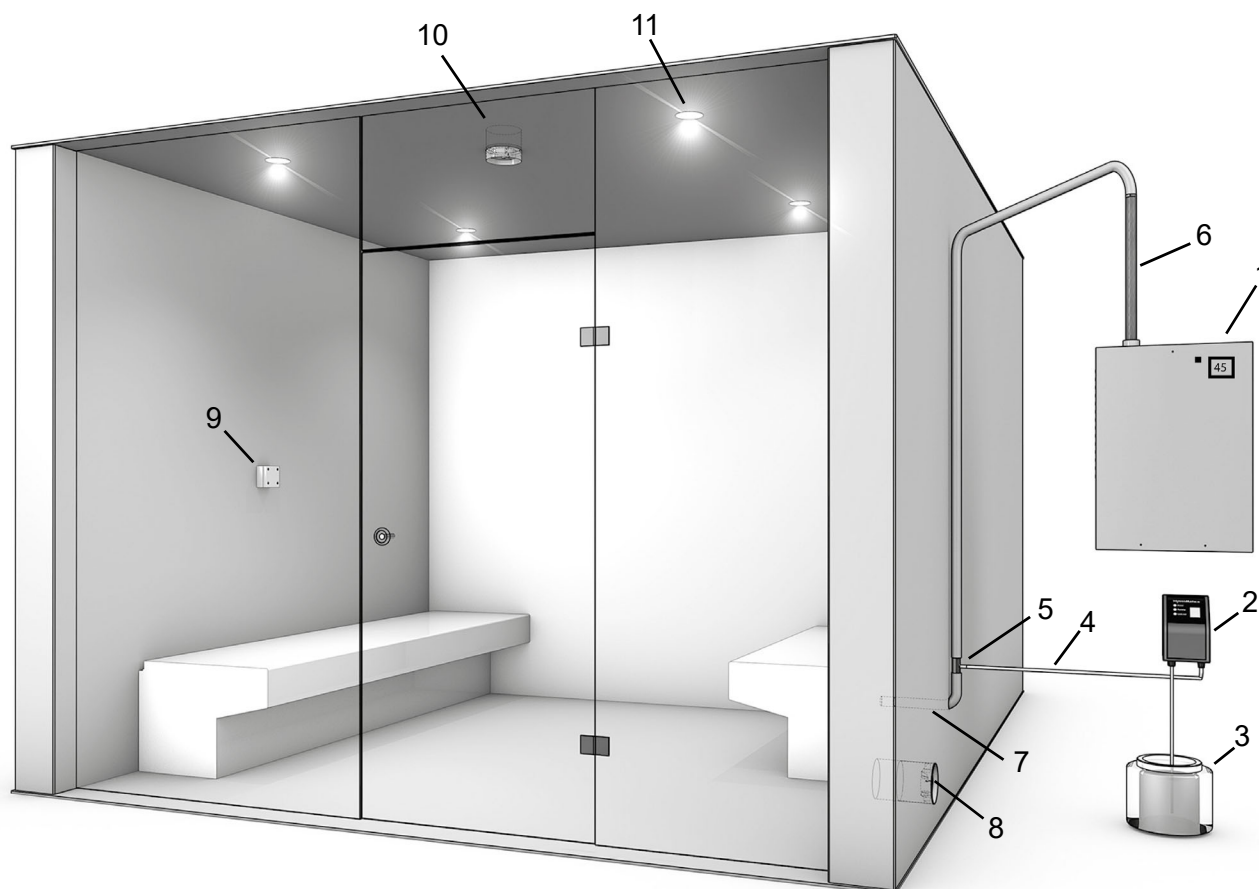

3.2 Temperature sensor usage

A temperature sensor must be installed in the cabin for a steam bath. The sensor measures the actual temperature and transmits the measurement value to the control. The temperature serves as the controlled variable for controlling the steam production.

3.2.1 Installation of the temperature sensor

The best mounting position of the temperature sensor is 800 to 1000 mm (31 to 39 inch) above the seating surface (and thus in the height of head of the persons in the steam bath cabin). The sensor must be mounted directly to the wall surface. Installation under a panelling would falsify the measurement result.

Please note

The sensor must not be mounted directly above the steam entrance into the cabin.

⚠ WARNING

Risk of scalding when steam bath temperature rises due to temperature sensor manipulation!

Do not cover the temperature sensor or pour over cold water.

3.2.2 Connection of the temperature sensor

The connection cable of the temperature sensor is to be wired to terminals 4 and 7 of the FlexLine SPA control. The sensor has been adjusted ex-factory. Verifying of the measurement value can be made by using the temperature/resistance table following below. Readjustment of the sensor can be made in a +/- 5 K range, if required. In this case, an additional temperature measurement device is required for referencing.

Temperature/resistance-table	
Temperature in °C	Resistance in kΩ
10	28,5
20	18,5
30	12,3
40	8,3
50	5,8
60	4,1
70	2,9
80	2,1

3.3 Steam bath temperature control

The steam output of the HygroMatik steam generator is controlled by the FlexLine SPA control according to the measured temperature. The **relative humidity** is not measured because it is **always 100%** after the heating-up phase. Essence injectors, lights and supply and exhaust fans, which are available as order options, can be connected to the steam generator.

The functioning of the temperature control is illustrated by the sample diagram in section 3.5, which is based on the following default values:

Steam bath temperature set value: **45 °C**

ΔTemp._steam_on/off: **1K**

(Temp._set value + Temp._steam_on/off) = 45 °C + 1K = **46 °C**

- When 46 °C has been reached, steam production is switched off in 1 step operation, during continuous operation (with the internal PI controller), it is reduced
- If the temperature in the steam bath drops below the set value 45 °C, steam production is resumed (1 step operation) or ramped up (continuous operation)

3.4 Fan control

The influences of the fan control of the supply and exhaust fans (both in automatic mode) are also illustrated in the sample diagram.

3.4.1 Supply fan

The supply fan is switched on by the control, as long as the steam bath temperature has not reached the set value. It switches off at (Temp._set value + supply fan 1_ΔTemp.) In the example:

Temperature set value: **45 °C**
Supply fan 1_ΔTemp.: **1K**

- The supply fan 1 switches off at $45\text{ °C} + 1\text{K} = \mathbf{46\text{ °C}}$
- Supply fan 1 switches back on again if the temperature falls below the temperature set value

If a second supply fan is used or if the supply fan has a 2nd power level, both supply fans are switched on until the temperature set value is reached. Analogous to supply fan 1, supply fan 2 is switched off when (Temp._set value + supply fan 2_ΔTemp.) is reached.

This mechanism is not illustrated in the sample diagram. Numerically, it could be represented as follows:

Temperature set value: **45 °C**
Supply fan 1_ΔTemp.: **2K**
Supply fan 2_ΔTemp.: **0.5 K**

- Supply fan 1 switches off at $45\text{ °C} + 2\text{ K} = \mathbf{47\text{ °C}}$
- Supply fan 2 switches off at $45\text{ °C} + 0.5\text{ K} = \mathbf{45.5\text{ °C}}$

3.4.2 Exhaust fan

The exhaust fan is switched on if the temperature set value is exceeded. The exhaust fan switches off when the temperature falls below (Temp._set value - exhaust fan 1_ΔTemp.). In the example:

Temperature set value: **45 °C**
Exhaust fan 1_ΔTemp.: **1K**

- The exhaust fan switches off at $45\text{ °C} - 1\text{K} = \mathbf{44\text{ °C}}$

If a second exhaust fan is used or if the exhaust fan has a 2nd power level, this additionally switches on if (set temperature value + exhaust fan 2_ΔTemp.) has been reached. This mechanism is not illustrated in the sample diagram. Numerically, it could be represented as follows:

Temperature set value: **45 °C**
Exhaust fan 1_ΔTemp.: **1K**
Exhaust fan 2_ΔTemp.: **0.5 K**

- Exhaust fan 1 switches on at **45 °C**
- Exhaust fan 2 additionally switches on at **45.5 °C**
- Both exhaust fans switch off at **44 °C**

Steam is only produced as long as the temperature in the steam bath is below the set temperature. If the temperature in the steam bath remains above the set temperature for a long time, i.e. **no visible steam** is produced, the reason for this can be:

- A high additional heat supply, e.g. due to heated benches
- Excessive insulation of steam bath
- Insufficient ventilation in the steam bath

An exhaust fan promotes the air exchange in the steam bath, leading to a faster temperature reduction in the steam bath. The temperature drop is compensated by renewed steam production. In this way, the fan ensures that there is a steady, constant production of steam and visible vapour in the cabin a result.

3.5 Sample diagram for temperature profile in steam bath

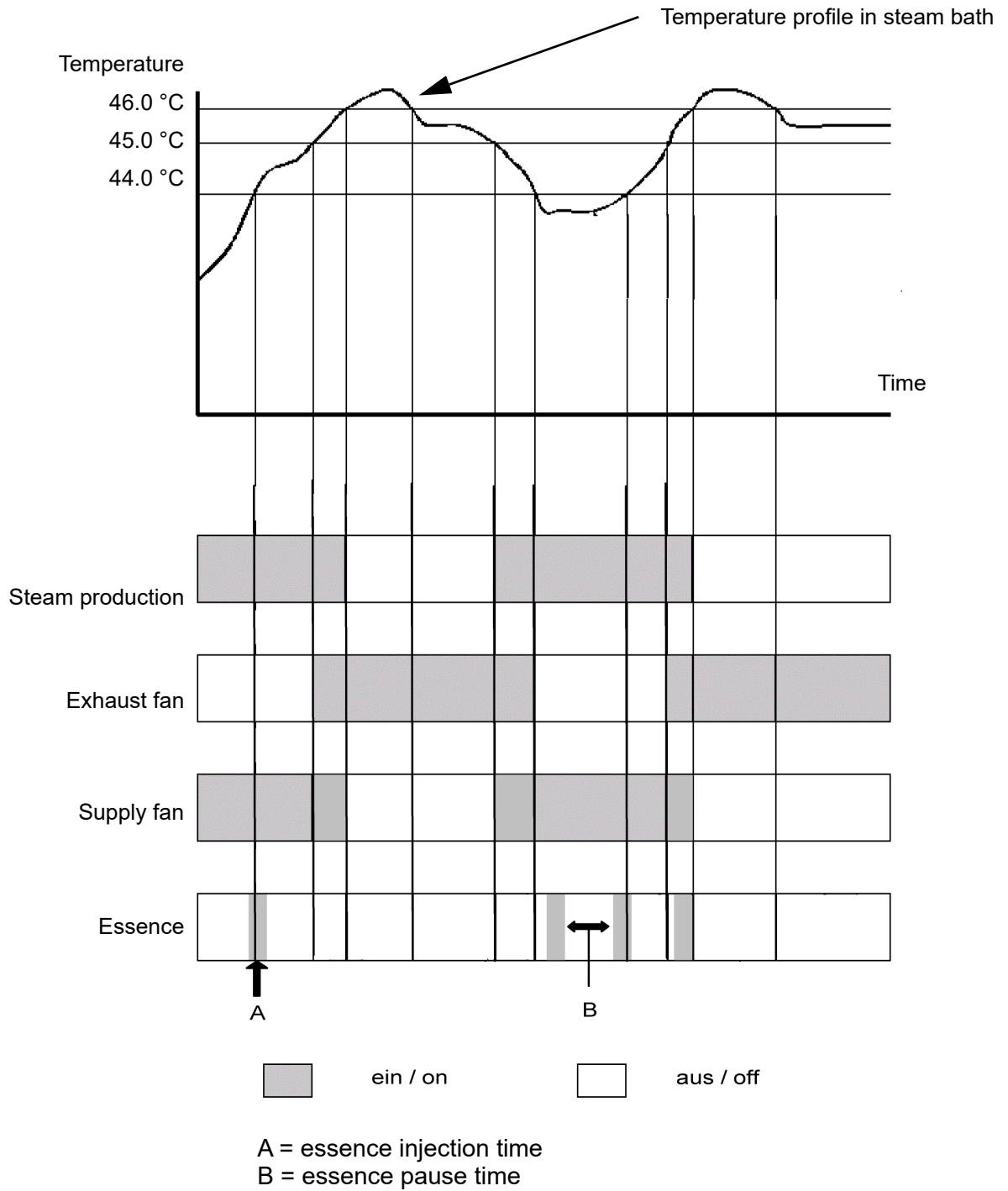

4. Description of control

4.1 General description

The control is integrated into the steam humidifier and is operated via a 3.5" graphic display on the front of the unit.

An additional operating element on the front of the unit is a control switch, whose positions are assigned as follows:

Pos. "0": The unit is switched off

Pos. "I": The unit is switched on

Pos. "II": The cylinder water is pumped off without the participation of the control. The control is not active, the display remains dark.

Control switch



By changing the parameters, the user/operator can adapt the control to the system specifications and the special characteristics relating to the use of the unit.

The operation of the unit is described in Section 6.

4.2 Layout of control

The control consists of the 3.5" screen and the mainboard. The mainboard can be extended for additional functions with one or 2 relay boards (with 3 relays each) and additional optional relays in DIN rail format.

The relay boards are connected to the mainboard via a plug system.

The DIN rail relays are connected via cables with plug. 2 additional relay modules can be used, with 2 relays each.

For use with double cylinder units, an extension board is added to the mainboard.

The fuse protection of the control voltage for all boards with 2 x 2.5 A Flink (F1, F2) takes place on the mainboard.

The external circuitry for the control voltage and the interlock (safety) system are connected directly to the mainboard on plug ST1. If additional boards are connected, the connection moves from the mainboard to the outermost board (see sketch).

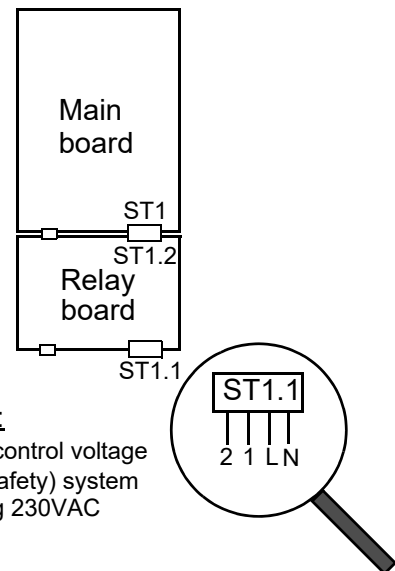

Please note

For device versions with separate control voltage, this is connected to clamps L and N. For versions with internal control voltage and control voltage transformer, the wiring is pre-installed here.

4.3 Mainboard

The mainboard is "the heart" of the control. All logic functions and control operations for the steam humidifier take place here. The relays for the control of the main contactor, solenoid valve and blow-down pump are arranged directly on the mainboard.

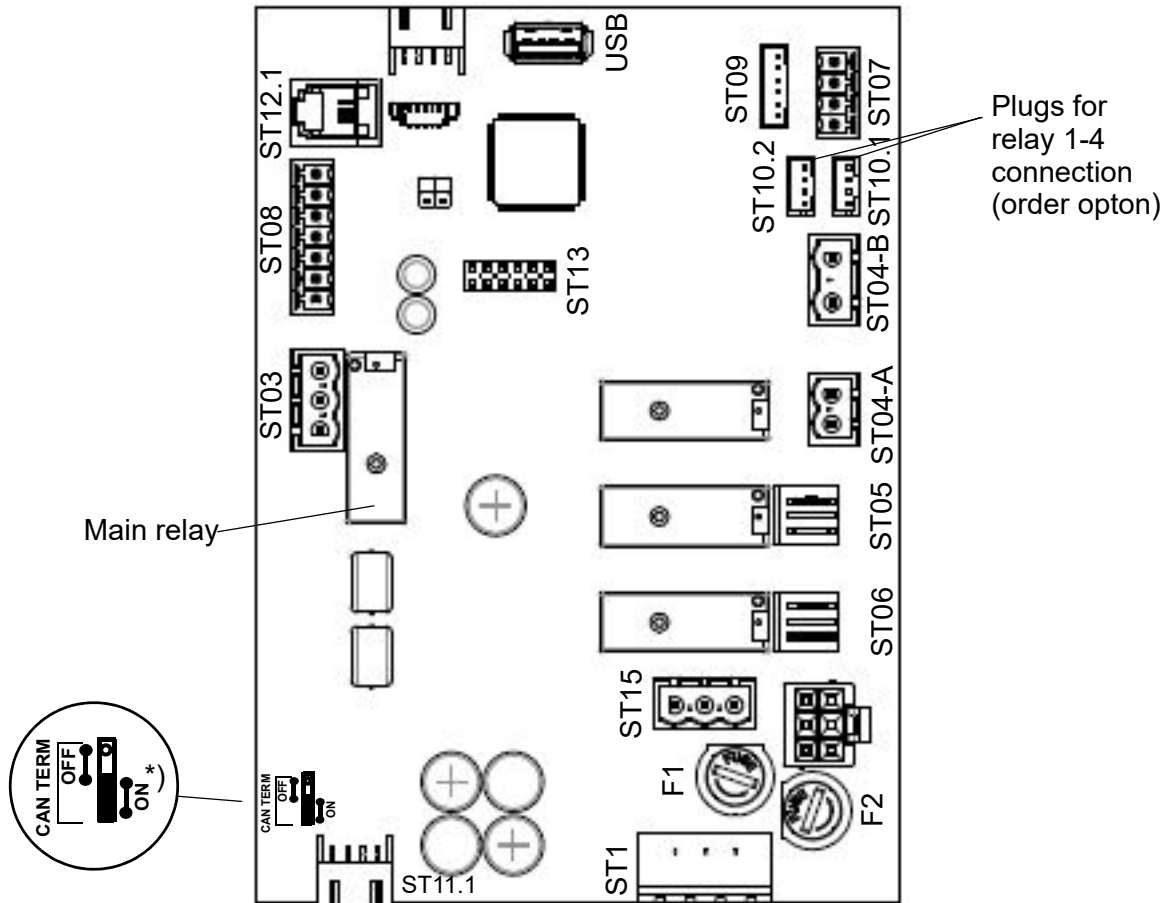

*) This jumper must always be set to „ON“

Ex-factory relay assignment:

In case of a unit without any additional options built in, assignment of the base relay (ST03) is „Collective fault“ (0). All other relay contacts carry the assignment „Not in use“ (284).

4.3.1 Connections on the mainboard

The use of the connections is illustrated by the wiring diagrams (see Chapter 8)

4.3.1.1 Customer-side computer interfaces

Inputs

ST08:

- Input for control signal of temperature sensor
- Configurable digital input 12 VDC

Outputs

ST03:

- Potential free break/make contacts NC and NO, programmable, relay assigned to "Collective fault" in factory setting

ST10.1/ST10.2:

- Connection options for optional relay each in top-hat rail version with wiring harness (order option)

ST07:

Control output 0...10 VDC (max. 8 mA)

ST08:

- +20 VDC supply voltage (max. 20 mA) for humidity sensors (can be used as auxiliary voltage for digital input)

ST15:

- Tap for 1,2 and N (max. 2.5 A) for customer use

USB:

Connection for USB stick for use as a data logger and for parameter or software updates

4.3.1.2 System-side interfaces

ST1:

- 4-pin screw / plug connection for the connection of L1 and N and the interlock (safety) system

ST11.1:

- +12 V, GND, CANbus

Inputs

ST09:

- Input for current transformer for ELDB (= Electrode steam humidifier) / level control for HKDB (heater steam humidifier) with automatic detection (for explanation of terms see Glossary, Index 7)

ST04-B:

- Galvanically isolated input (optical coupler) for sensor electrode for ELDB

Outputs

ST04-A:

- Main contactor

ST05:

- Blow-down pump

ST06:

- Inlet solenoid valve

Bi-directional

ST12.1:

- Serial interface for screen connection

ST 13:

- Base for adapter board with RS485 interface

4.4 Expansion board (double cylinder units)

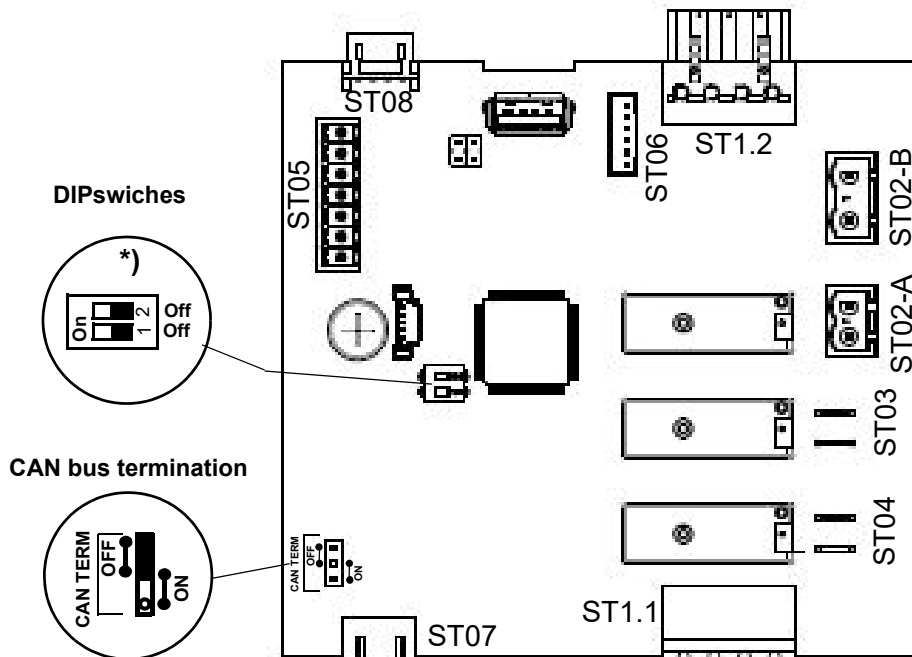

^{*)}The DIP switches

serve for CAN bus address setting. They are factory preset according to the unit configuration.

^{**)} The jumper for the CAN bus termination is in the „ON“ position only on the lowest extension or relay board of the assembly, i.e. the termination is then effective. On the boards that are attached in higher mounting positions, the correct

4.4.1 Connections on the expansion board

4.4.1.1 Customer-side computer interfaces

Inputs/outputs

ST05: not used

4.4.1.2 System-side interfaces

ST1.1:

- 4-pin screw / plug connection for the connection of L1 and N and the inter-lock (safety) system

ST1.2:

- Loop-through of ST1.1

ST07:

- +12 V, GND, CAN-Bus

ST08:

- Loop-through of ST07

Inputs

ST02-B

- Electrically isolated input (optical coupler) for sensor electrode (ELDB)
- Thermoswitch connection (HKDB)

ST06:

- Input for current transformer (ELDB) / level control (HKDB) with automatic detection

Outputs

ST02-A:

- Main contactor

ST03:

- Blow-down pump

ST04:

- Inlet solenoid valve

4.5 Relay circuit board

The relay board has three additional relays with potential free break/make contacts (contact load 250 VAC/8 A) for switching or controlling of additional functional units or options.

A maximum of 2 relay boards can be installed. When 2 boards are in use, different CAN bus addresses must be set (see fig. below).

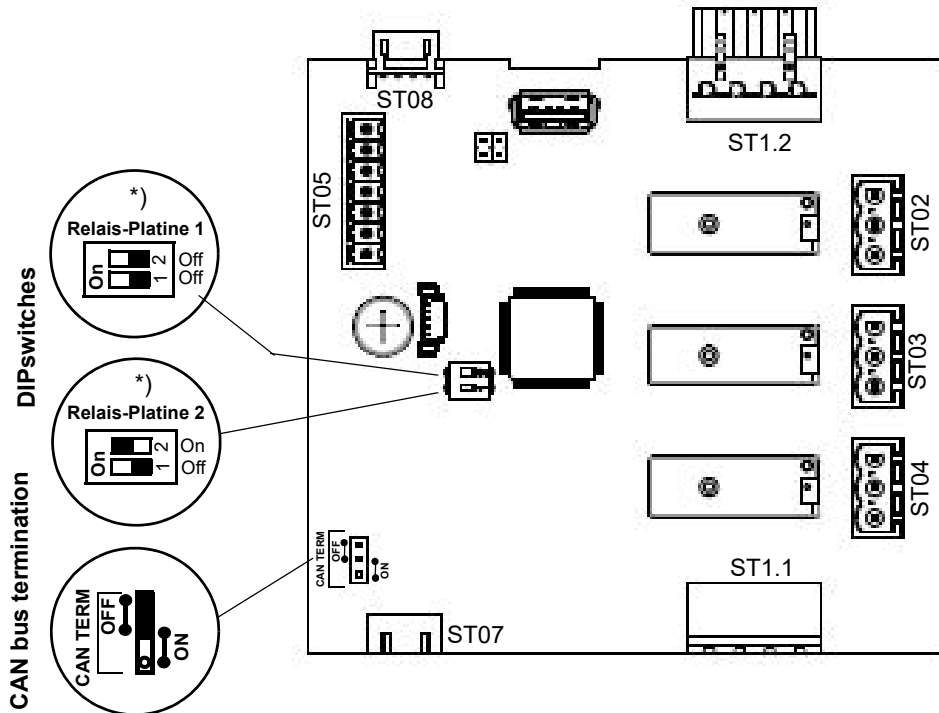

*) The DIP switches serve for CAN bus address setting. They are factory preset according to the unit configuration.

**) The jumper for the CAN bus termination is in the „ON“ position only on the lowest extension or relay board of the assembly, i.e. the termination is then effective. On the boards that are attached in higher mounting positions, the correct jumper setting is „OFF“. On the main board the correct setting of the Can-Bus termination is always "ON".

4.5.1 Connections on the relay board

4.5.1.1 Customer-side interfaces

Inputs

ST05:

- Configurable digital input 12 VDC

Outputs

ST02:

- Potential free break/make contacts NC and NO, programmable

ST03:

- Potential free break/make contacts NC and NO, programmable

ST04:

- Potential free break/make contacts NC and NO, programmable

4.5.1.2 System-side interfaces

ST1.1:

- 4-pin screw / plug connection for the connection of L1 and N and the inter-lock (safety) system

ST1.2:

- Loop-through of ST1.1

ST08:

- +12 V, GND, CAN bus

ST07:

- Loop-through of ST08

4.6 Electrical connection

⚠ WARNING

Danger of electric shock!

Dangerous electric voltage!

All work relating to the electrical installation may only be carried out by designated specialist personnel (electrician or qualified person with equivalent training).

Please note

The customer / operator is responsible for monitoring the qualifications of the specialist personnel.

NOTICE

Potential component damage due to electrostatic discharge!

To protect the sensitive electronic components, measures to prevent damage due to electrostatic discharge must be taken before the start of the installation work.

4.6.1 Connection of control voltage

The control voltage of 230 VAC is to be applied to the board which is closest to the cable gland on the underside of the housing. The plug designation differs depending on the level of expansion:

Type of board	Plug designation
Mainboard	ST1
Extension board	ST1.1
Relay board	ST1.1

The pin assignment is identical for all plugs. L and N are labelled on the boards. The pins are accessible via a terminal strip adaptor pushed on the corresponding plug.

For device versions with internal control voltage, no voltage must be applied to L and N. The wiring is pre-installed here.

4.6.2 Connection of interlock (safety) system

⚠ WARNING

Danger of electric shock!

Dangerous electric voltage!

After the commissioning of the unit, a 230VAC voltage is present at terminal 1 when standard wiring is used.

The so-called interlock (safety) system is located between terminals 1 and 2 with terminal 1 holding 230 VAC. For closing the interlock, a make contact is required across terminals 1 and 2. This contact is supplied by relay K21. For energising the relay, a make contact or a bridge is required across the additional terminals on the hat-top rail.

If the interlock (safety) system is open, the humidifier does not start or the operation is interrupted.

Interlock (safety) system

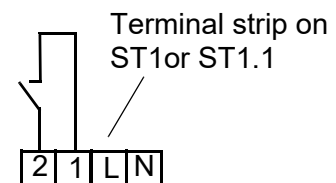

Terminals 1/2 on the mainboard (terminal strip on ST1) or on the extension/relay board (terminal strip on ST1.1) for the connection of the interlock (safety) system

If steam operation is interrupted for a longer period of time, it is recommended to switch off the steam generator or to open the safety chain. The latter makes it possible to control external consumers, e.g. an exhaust fan during the fan run-on time to dry out the steam bath, although steam operation is interrupted.

NOTICE

We recommend the use of safety systems (e.g. a door contact switch).

Please note

The interlock (safety) system is not closed when delivered ex-factory!

The contacts, which are connected to terminals 1 and 2 must be potential free and suitable for switching of 230 VAC.

4.6.3 Connection of the temperature sensor(s)

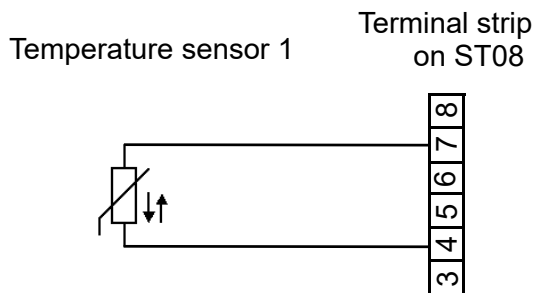

Connection of temperature sensor 1 to the mainboard

If a 2nd temperature sensor is used, this is to be connected to the extension board or to relay board 1 (if several relay boards are present):

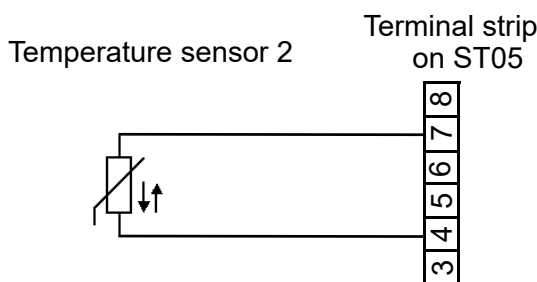

Connection of temperature sensor 2 to extension board or relay board 1 (if an extension board is not present)

4.6.4 Connecting the digital input (DI)

The digital input on the mainboard can be used for switching functions.

The digital input must be wired on-site in accordance with its use, e.g. with a push-button or a switch (also see chapter 6.8.8 „Function parameters“ / „Function_digital_input“).

Wiring the digital input (DI):

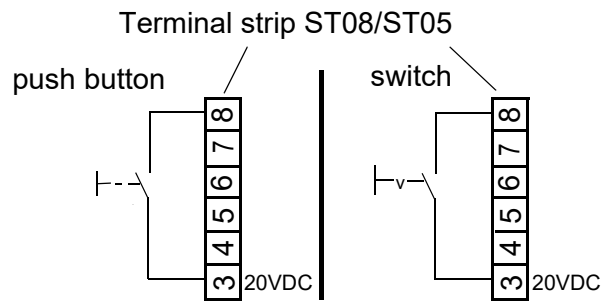

Terminals 3/8 provided for connecting the digital input

- mainboard (terminal strip ST08)
- extension board/relay board (terminal strip ST05)

4.6.5 Wiring for control signal and safety (interlock) system for multiple units

In the case of multiple units, separate humidifiers work together. The control signal and the safety (interlock) system are connected to the master unit as described above. In addition, connecting cables are established between the guiding unit and the succeeding unit(s) (provided on-site). These provide the succeeding unit with a control signal from the guiding unit and the transmitted (potential free) safety (interlock) system.

The wiring for the control signal and the safety (interlock) system must be implemented as follows for multiple units:

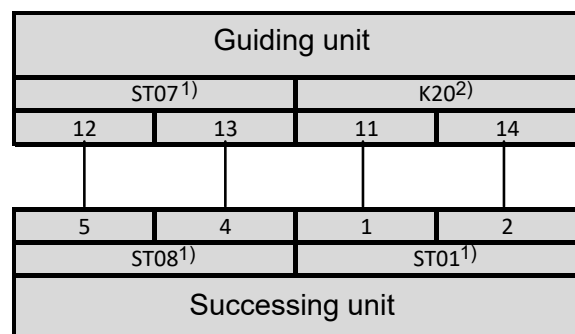





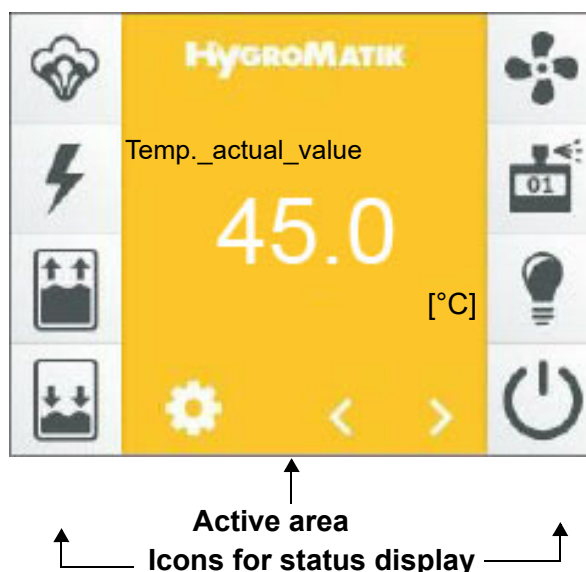

¹⁾ „ST0x“ designates connector plugs on the mainboard

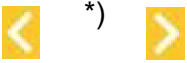





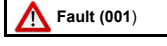

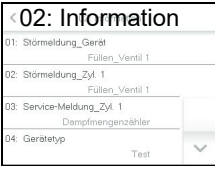
²⁾ „K20“ is the relay used for the connection of the succeeding unit with the installed option (CN-07-10012) or the enclosed option (CN-07-10002)

5. The display



Active display area	Use
	<p>Main display for operating values, navigation using the scroll keys^{*)}</p>
 <p>^{*)}</p>	<p>Scroll keys, used to display the following operating values:</p> <ul style="list-style-type: none"> Temp._actual value [° C] Temp._set value [° C]^{1,2)}, can be changed using the on-screen keyboard^{**) after tapping on it} Steam_actual_unit [kg/h] Steam_output_max. [%] Demand [%] Control_signal_internal [%] Output signal [V] Current_actual_Cyl. 1[A] (only for electrode steam humidifier ELDB) Current_actual_Cyl. 2 [A] (only for ELDB double cylinder units) Water_level_cyl. [mm] (only for heater steam humidifier HKDB) Water_level_cyl. 2 [mm] (only for HKDB double cylinder units) Essence_selection1 (1... 4, if enabled) <p>1) only when PI-controller is set 2) the display and option to change the temperature set value is not available with weekly timer operation; with the following exception: If "ECO" is selected for the steam generation, the temperature set value display is also available in the weekly timer operation.</p>
<p>^{**)}</p> 	<p>On-screen keyboard for changing the Temp._set value; is displayed after tapping on the temperature set value display and is used for the direct input of the set value.</p> <p>Confirm the input and save using the check mark in the top right, cancel using the "X" in the top left.</p>

Active display area	Use
	Icon to open set-up mode (via password prompt). Password "000" -> operating functions of user level (see Section 6.5) Password "010" -> operating functions of operator level (see Section 6.7)
  	In the event of a fault or a service message, the relevant display field is shown instead of the HygroMatik logo. Tapping on it opens the unit info screen (see Section 6.9).
	Unit info screen (see Section 6.9) for the display of fault and service messages in plain text. Is displayed by touching the fault or service message.

Icon	Status	Meaning
	dark bright flashes	Steam generation active No steam generation Cylinder full state; after 1 hour: cylinder full fault
	dark bright flashes	Main contactor switched Main contactor not switched Fault main contactor
	dark bright flashes	Filling active No filling Fault filling
	dark bright flashes	Blow-down active No blow-down Fault blow-down <u>Manual blow-down</u> A manual blow-down can be triggered by tapping on the icon. Touching the icon again stops the manual blow-down.
	dark bright flashes	Fan function active Fan function not active Fan working
	dark bright flashes	Essence function active Essence function not active Essence is fed
	dark bright	Light active Light not active
	dark bright flashes	Operating mode display No temperature control enabling due to e.g. timer expiry or under weekly timer control (details can be found in Read_values/Status_unit). Unit is in the initialisation phase

6. Operation of control

6.1 Operation basics

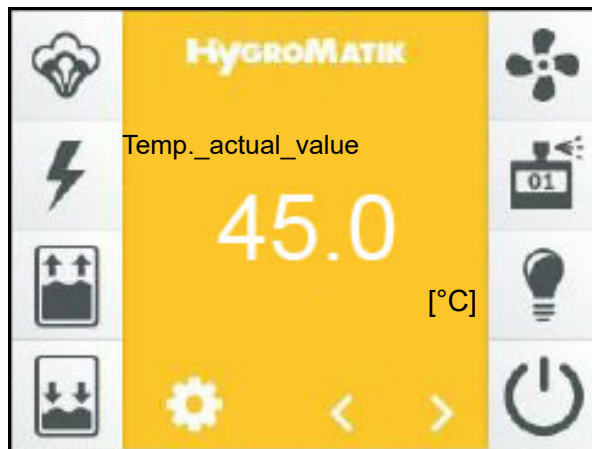

Operation takes place via the built-in touch-sensitive 3.5 inch display. It is used for all operating steps which are required for the settings and operation of the unit. In addition to operating the unit directly, it is possible to control it remotely via the building technology control system or a PLC, using the communication interface. Supplementary documentation is available from HygroMatik for this type of application.

Screen views

The operating structure uses several screens, which are schematically displayed in the table below.

User guidance

In the user guidance, a distinction is made between the "user level" and "operator level". While the user level only makes it possible to carry out basic device operations, the operator level also makes it possible to make comprehensive parameter and unit settings. The possible operating functions of the two levels are presented in the following sections.

Overview of the screens

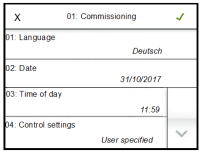
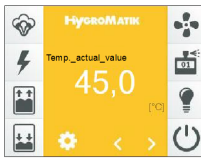
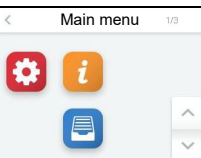
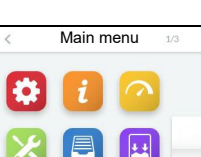
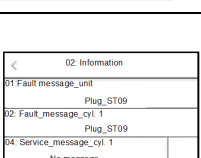
	Content of screen page	Presentation	Sec.
Screen 1 Commissioning	Used for the basic unit settings (e.g. user language) after the unit is switched on for the first time. This page is then closed. To do so, use the confirmation tick to exit it.		6.2
Screen 2 Main screen	Displays the current operating values and unit status information (status icons).		6.3
Screen 3 Main menu (user level)	Allows access to submenus for comprehensive unit settings, reading values and history.		6.5
Screen 3 Main menu (operator level)	Allows access to submenus for comprehensive unit settings, reading values, parameter settings, service settings and history.		6.7
Screen 4 Unit information	Is only displayed after a fault or a service message has occurred; provides information on device data, statistics, faults that have occurred and service requirements.		6.9

Operating ranges at the user/operator level

Level	Permits
User level	<ul style="list-style-type: none"> • Display of the reading values of the main screen • Setting the temperature set value in the main screen • Display of the unit information after a fault or status message • After password entry: Display of the complete list of reading values and adjustment options for some service parameters
Operator level	<ul style="list-style-type: none"> • All functions of the user level • Advanced settings options for operation and service parameters

6.2 Screen 1 - Commissioning

After connection to the mains supply and initial actuation of the control switch, the commissioning screen for the basic device settings appears on the display once the self-test of the control has been completed:

X	01: Commissioning	✓
01: Language	English	
02: Date	31/10/2017	
03: Time	11:59	
04: Control	User-defined	

6.2.1 Setting the language

- » Tap on the line with parameter "01: Language". The following screen is displayed:

<	Language	✓
German		
English		✓
Français		
Castellano		∨

- x The currently selected language is marked with a tick in the relevant line. By tapping on the scroll-down icon, the 2nd page of the screen is displayed if required
- » Change the language by tapping on the language selection

- » Confirm the input and return to the "Commissioning" screen with the green tick in the top right (cancel by tapping on "X" in the top left)

6.2.2 Input of date and time of day

The parameters "02: Date" and "03: Time of day" require digits to be entered. To do so, a screen with a keyboard and an input field in the date or time format will be displayed after tapping on the relevant line.

As an example, the date input is described below:

- » Tap on line "02: Date". The following screen is displayed:

X	Date	✓
28/10/17		
1	2	3
4	5	6
7	8	9
.	0	X

- » Enter the date in the format DD/MM/YY (D = day, M = month, Y= year) as digits only (the forward slashes are added automatically)
- » Confirm the input and return to the "Commissioning" screen with the green tick in the top right (cancel by tapping on "X" in the top left)

6.2.3 Control settings

The control behaviour of the control is set in the next step. The following variants are offered for selection on the screen: 1 step operation (on/off control) or the use of the internal PI controller. If the unit was already factory-preset according to customer requirements, the selection tick appears in the "User-defined" line.

The parameters are displayed in blocks on a screen page, which include a maximum of 4 entries. Scroll icons are used to switch between the individual display blocks.

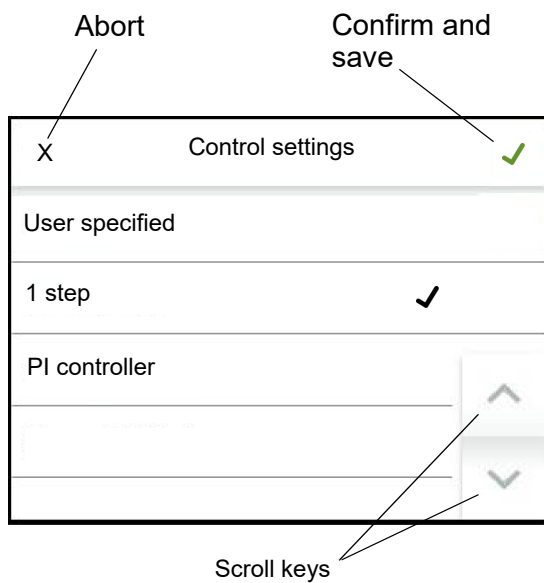

- » Confirm the input and return to the "Commissioning" screen with the green tick in the top right (cancel by tapping on "X").
- » Tapping the green tick in the top right again saves the entries and exits the commissioning screen (cancel by pressing the "X" in the top left).

The commissioning is now complete. If the commissioning screen was exited with the confirmation tick, the main screen is now shown in the display.

The commissioning screen is no longer displayed in future. Changes which are made at a later stage to the parameters listed during commissioning must then be performed at the operator level in the "Settings" and "Control" submenus.

Line-up of the commissioning parameters

01: Commissioning

No.	Parameter	No.	Adjustment/value range			Meaning/Comment
			Factory setting (FS)	Min	Max	
1	Language		Selection			Selection of language
		0				Deutsch
		1				English
		2				Français
		3				Castellano
		5				Italiano
		6				Русский
		7				Svensk
2	Date			DD.MM.YY		Set date
3	Time_of_day			HH:MM		Set time
4	Control_settings		Selection			Combinations of control type and input signal type/range
		0				User_specified The selection was carried out separately during initial operation according to control type, signal type and area. This is a read value only
		7				1-step 1 step operation [44]
		10				Pi-controller Control with internal PI controller [96]
5	Recording		Selection			Recording [93] of parameter sets
		0				Deactivated No recording
		1				Activated Start recording

6.3 Screen 2 - Main screen

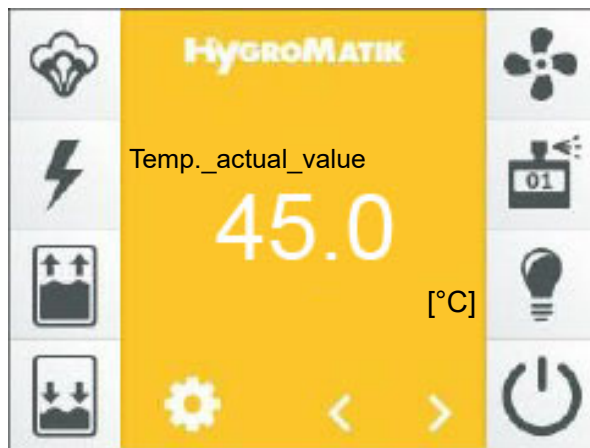



The values for the normal display brightness and the dimmed state can be adjusted by the user, as well as the time after which the main display is dimmed.

The main menu of the user level and the operator level (screen 3 „Main menu“) are accessed by tapping on the icon  .

The main screen is shown in the display after the unit is switched on, unless the unit is being switched on for initial commissioning (see Section 6.2). In the main screen, current operating values are represented as numerical information, as well as status information in the form of icons. The display elements were described in the Section "The display". A flashing icon always indicates a fault.

The left row of icons refers to the operational conditions of the unit. The right row of icons indicates the status of releases. For steam production to take place, all icons on the right side of the display must be active.

The scroll icons  and  allow the user to move through the list of display values on the main display (see Section 5, "The display"). With the exception of the temperature set value, these are reading values only. The values displayed are listed and explained in the table in the following section.

If a fault has occurred or a service message is issued, a display field with the relevant message is displayed instead of the Hygro-Matik logo. The user can access the unit info screen by tapping on this field.

The brightness of the main screen is reduced after a preset time (display brightness is dimmed). The two scroll icons and the settings icon are also hidden at this point. The original state is restored by tapping on the display.

Table of the reading values available in the main display and the set value of the steam bath temperature

Main display

No.	Parameter	No.	Adjustment/value range			Meaning/Comment [] explains the term in the glossary →[] refers to a related explanation of the term
			Factory setting (FS)	min	max	
3	Temp._actual_value			Read value		Actual value [1] of temperature in °C
4	Temp._set_value		20,0	49,0	45,0	Set value [3] of steam bath temperature in °C
7	Steam_actual_unit			Read value		Current steam output of the unit [4] in kg/h
9	Steam_output_max.			Read value		Set value of maximum output power [43]
10	Demand			Read value		The demand [5] is the control signal from which the internal actuator signal [42] is created
11	Control_sig_internal			Read value		Internal actuator signal [42] as a percentage of the actuator signal for the nominal output
12	Output_signal			Read value		Output signal [69] on terminals 12, 13 proportional to input signal
13	Current_actual_cyl. 1			Read value		The current power consumption of cylinder 1 (only for ELDB [77])
14	Current_actual_cyl. 2			Read value		The current power consumption of cylinder 2 (only for ELDB [77] double cylinder units)
15	Water_level_cyl. 1			Read value		Water level in cylinder 1 in mm (only for HKDB [78])
16	Water_level_cyl. 2			Read value		Water level in cylinder 2 in mm (only for HKDB [78] double cylinder units)
19	Essences_selection			Read value		The selected essence pump from No. 1 to No. 4

6.3.1 Changing the set point temperature

- » Select the "Temp._set value [°C]" screen using or .
- » Tap on the Temp._set value display.
- » Enter the value of the intended temperature set value using the on-screen keyboard which has opened.
- » Confirm the input and save using the check mark in the top right, cancel using the "X" in the top left.

6.4 Password entry

The password determines if the main menu of the user level or the operator level is displayed. The password codes in use are:

Code 000: The main menu of the **user level** becomes accessible. However, it is sufficient to leave the password prompt with the green tick, without explicitly entering the code.

Code 010: The main menu of the **operator level** becomes accessible.

The password entry is called up in the main screen by tapping on the icon . An on-screen keyboard is displayed for entering the password:





The operator level is accessed through the sequential input of the code digits "0", "1" and "0" and confirming them with the green tick (top right).

6.5 Screen 3 - Main menu (user level)

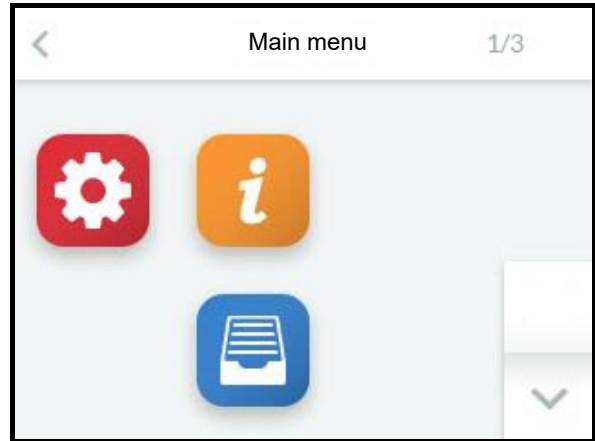
After selecting the user level (code 000), the icons of the submenus which are available to the user are displayed:



6.6 User level submenus

Icon	Opening of submenu
	Settings
	Reading values
	History

By tapping on the respective icon, the user accesses the screen page where the parameters of the respective group are displayed for selection, viewing or for making changes.

Layout of screen pages

The input fields in which changes can be made are shown in *italics*. Depending on the parameter, the input has to be made by:

- Selection from predefined offers (multiple choice, see example 1)
- Entry of numeric values using an on-screen keyboard (see example 2).

Example 1: Selection of user language:

Call up the language selection on the screen by tapping on the "Settings" icon and then on "Language":



By tapping on the language required, the black tick is displayed in the corresponding row. Using the green tick (top right), the selection is saved and the display returns to the parent screen.

If the settings are to remain unchanged, it is possible to return straight away using the icon ◀ in the top left.

Example 2: Setting the display brightness

Tap on "Display lighting_normal" on the screen to call up the input mask:

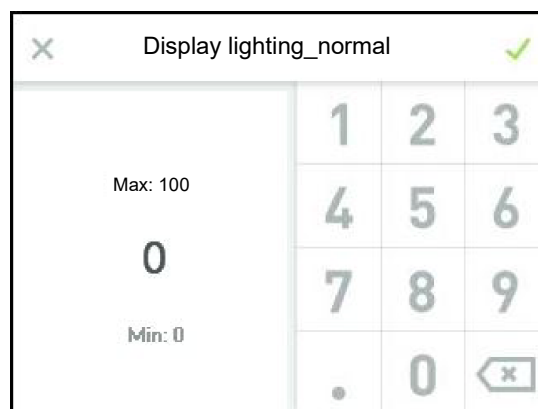

The display brightness which is set is displayed and can be changed using the keyboard. Save and return with the green tick, leave the input mask without changes using the "X" in the top left.

The screens are hidden after an adjustable period of time. The main screen is then displayed.

If a submenu is to be called up again after a screen has been closed automatically by a time-out, this can only be done through the settings icon in the main screen. This also means that the password has to be re-entered. As long as the user continues their work in the area of the main menu, the existing access remains, i.e. no renewed password entry is required.

6.6.1 Settings submenu



Table of settings parameters

03: Settings

No.	Parameter	No.	Adjustment/value range			Meaning/Comment [] explains the term in the glossary →[] refers to a related explanation of the term
			Min	Max	FS	
1	Language		Selection see: 01-1 Language			Selection of language
2	Date		DD.MM.YY			Set date
3	Time_of_day		HH:MM			Set time
4	Display_lighting_normal		5	100	100	Screen backlight in undimmed state
5	Delay_present_page		0	3600	300	Display duration for a certain screen page before return to the main screen in min
6	Display_lighting_dimmed		0	100	50	Screen brightness for dimmed state
7	Display_dim_after		0	3600	120	Switching of screen brightness of main screen to dimmed value after ... seconds. If an error has occurred or a status message is displayed, the main screen is not dimmed
8	Units		Selection			Selection of system of units
		0	SI			Units are displayed in the format of the SI system of units [8]
		1	Imperial			Units are displayed in the format of the imperial system of units [9]

6.6.2 Reading values submenu



Read values table (visible on the user and the operator level)

04: Read_values

No.	Parameter	No.	Adjustment/value range Factory setting (FS) Bold Min Max FS	Meaning/Comment [] explains the term in the glossary →[] refers to a related explanation of the term
1	Status_unit		Read value	Operating condition of unit
		0	Initialization	Control performs initialisation [10]
		1	Safety_interlock_open	Unit is ready for humidification, but the safety interlock [11] is open.
		2	No_Demand	Unit is ready for humidification, but there is no demand [5].
		3	Humidification	Humidifying [47]
		4	Runtime_limitation	Unit has switched off after limitation of operating time was reached [32]
		5	Remote_off	Unit was switched off via a software command [12] for opening the interlock (safety) system [83] via the communication interface [13]
		6	No_bus-signal	Steam production was switched off manually via the on/off button [14]
		7	Standby_heating_heating	The standby heating [16] is in the heating phase
		8	Standby_heating_interval	The standby heating [16] is in the resting phase
		9	No_demand_ECO	There is no demand [5] in ECO mode [61]
		10	Humidification_ECO	Humidifying in ECO mode [61]
		11	Timer_steam_off	Steam is not produced after the timer [18] has expired
		13	Weekly_timer_steam_off	No steam is produced after the weekly timer has run out
		14	Digital_input_steam_off	Steam production was cut via the digital input [97]
		16	Water_inlet_steam_off	Die Anlage nicht genügend Eingangswasserdruck hat und schaltet ab.
		21	DI_2_Dampf_aus	
		22	DI_3_Dampf_aus	
		23	DI_4_Dampf_aus	
		270	Service_message	A service message has appeared. For detailed specification, see read value 8 for cyl. 1 and read value 9 for cyl. 2 (double cylinder units only)
		900	Diagnosis	Unit is performing diagnostics [15]
		901	Not_programmed	The control electronics is not yet programmed for the unit type
		902	Update_in_progress	A USB stick was plugged in and a parameter upgrade is run by the unit
		903	Restart	A parameter upgrade was successfully carried out. Restart of the unit is required
		999	Fault	There is a fault
2	Status_cyl. 1		Read value	Status of cylinder 1
		0	Initialization	Unit is in initialization phase →[10]
		1	Safety_interlock_open	Cyl. 1 is ready for steam production, but the interlock (safety) system [11] is open
		2	No_Demand	Cyl. 1 is ready for steam production, but there is no demand [5]
		3	Humidification	Humidifying [47]
		30	Filling_valve 1	Filling via solenoid valve 1 [19]
		32	Filling_valve 1 a. 2	Filling via solenoid valve 1 and solenoid valve 2 [19]
		45	Fill_delayed	Es steht kein Zylindervollstand mehr an, das Nachfüllen wird momentan verzögert
		60	Start_blow-down	At the start of operation, the unit performs a start blow-down [20]
		61	Part._blow-down	A partial blow-down [21] is performed
		62	Full_blow-down	A full blow-down [22] is performed
		63	Dilution	The unit performs a dilution [23] of the cylinder water (only ELDB [77])
		64	Max._current_blow-down	The unit performs an overcurrent blow-down [24] because the measured current is too high (only for ELDB [77])
		65	Max._level_blow-down	The unit performs a max. level blow-down [25] because the water level is too high (only for HKDB [78])
		66	Standby_blow-down	The unit performs a Standby blow-down [26], because the maximum duration without demand [5] has been reached
		67	Dead_leg_flushing	A dead-end line flushing is performed [27]
		68	Manual_blow-down	A manual blow-down [28] was triggered
		81	Part._blow-down_pending	A partial blow-down [21] is performed before the next filling process
		82	Full_blow-down_pending	A full blow-down [22] is performed before the next filling process
		90	Cylinder_full	The sensor electrode reports when the maximum water level in the cylinder has been reached (only for ELDB [77])
		270	Service_message	A service message has appeared. For detailed specification, see read value 8 for cyl. 1 and read value 9 for cyl. 2 (double cylinder units only)
		900	Diagnosis	The unit is in diagnostic mode [15]
		999	Fault	There is a fault
3	Status_cyl. 2		Read value	Status of cylinder 2 (as cylinder 1)
			see: 04-2 Status_cyl. 1	
4	Fault_message_unit		Read value	List of possible unit fault messages
			see: 02-1 Fault_message_unit	
5	Fault_message_cyl. 1		Read value	List of possible fault messages for cylinder 1 (see Fault_message_unit)
			see: 02-2 Fault_message_cyl. 1	
6	Fault_message_cyl. 2		Read value	List of possible fault messages for cylinder 2 (see Fault_message_unit)
			see: 02-2 Fault_message_cyl. 1	
7	Service_message_unit		Read value	Service message unit
			see: 02-4 Service_message_unit	
8	Service_message_cyl. 1		Read value	List of service messages for cylinder 1
			see: 02-4 Service_message_unit	
9	Service_message_cyl. 2		Read value	List of service messages for cylinder 2
			see: 02-4 Service_message_unit	
10	Steam_actual_unit		Read value	Current steam output of the unit [4] in kg/h
11	Steam_actual_cyl. 1		Read value	Current steam output [4] of cylinder 1 in kg/h (for double cylinder units)
12	Steam_actual_cyl. 2		Read value	Current steam output [4] of cylinder 2 in kg/h (for double cylinder units)

Read values table (ctd.)

No.	Parameter	No.	Adjustment/value range			Meaning/Comment [] explains the term in the glossary →[] refers to a related explanation of the term
			Factory setting (FS)	Min	Max	
16	Output_max.				Read value	Set value of maximum output power [43]
17	Demand				Read value	The demand [5] is the control signal from which the internal actuator signal [42] is created
18	Control_sig_internal				Read value	Internal actuator signal [42] as a percentage of the actuator signal for the nominal output
19	Output_signal				Read value	Output signal [69] on terminals 12, 13 proportional to input signal
20	Safety_interlock	0 1	Off On		Read value	Status of the interlock (Safety) system [11] The interlock (safety) system is open The interlock (safety) system is closed
21	Safety_interlock_virtual	0 1	Off On		Read value	Status of the virtual interlock (safety) system [86] The interlock (safety) system is open The interlock (safety) system is closed
22	Current_actual_cyl. 1				Read value	The current power consumption of cylinder 1 (only for ELDB [77])
23	Current_actual_cyl. 2				Read value	The current power consumption of cylinder 2 (only for ELDB [77] double cylinder units)
24	Water_level_cyl. 1				Read value	Water level in cylinder 1 in mm (only for HKDB [78])
25	Water_level_cyl. 2				Read value	Water level in cylinder 2 in mm (only for HKDB [78] double cylinder units)
28	Model				Read value	Type designation of unit
29	Unit_name				Read value	Unit name [90], can be selected by the customer, if required
30	Serial_number				Read value	Serial_number
31	Date_of_manufacturing				Read value	Date_of_manufacturing
32	Controller_series				Read value	Type of control
33	Software_version				Read value	Software version of control
38	Temp_set_value				Read value	Set value [3] of temperature in °C
39	Temp_actual_value				Read value	Actual value [1] of temperature in °C
40	Temp_actual_value 1				Read value	Actual value [1] of temperature in °C as measured by temperature sensor 1 when 2 temperature sensors are in use
41	Temp_actual_value 2				Read value	Actual value [1] of temperature in °C as measured by temperature sensor 2 when 2 temperature sensors are in use
46	Steam_amount_total_cyl. 1				Read value	Entire steam volume of cylinder 1 [kg] produced since initial operation
47	Steam_amount_total_cyl. 2				Read value	Entire steam volume of cylinder 2 [kg] produced since initial operation (double cylinder units only)
50	V_Signal				Read value	Voltage signal measured on terminal ST0505
51	mA_Signal				Read value	Current signal measured on terminal ST0506
52	Ω_Signal				Read value	Resistance signal measured on terminal ST0507
53	Digital_input	0 1	Off On		Read value	Actual state of the digital input [97] No switching signal Switching signal present
54	Nominal_current_cyl. 1				Read value	Nominal current of cylinder 1 of the humidifier in A
55	Nominal_current_cyl. 2				Read value	Nominal current of cylinder 2 of the humidifier in A
69	Unit_total_runtime				Read value	The total runtime of the unit since its first connection to the power supply (specified in days/months/years/hours/minutes)

6.6.3 History submenu



This submenu is identical on the user and the operator level.

6.6.3.1 Explanation of history management

The control stores 10 sets of error messages on a rolling basis. Once there are 10 records, the oldest record is overwritten by a current entry. An error message set consists of the following entries:

1. Date of error message
2. Contents of error message
3. Frequency of error message
4. Error origin

If an identical error occurs several times in a row, the first entry relating to this error is updated with the date of the most recent occurrence and the frequency is incremented. A new error message set is not recorded.

The situation is different if a particular error occurs multiple times, but not in direct succession. In this case, a new error message set is written for each instance.

Table of history layout

07: History

No.	Parameter	No.	Adjustment/value range Factory setting (FS) Bold min max FS	Meaning/Comment [] explains the term in the glossary →[] refers to a related explanation of the term
1	1st fault_entry_date		Read value	1. Memory entry: Date/time
2	1st fault_entry_message		Read value	1. Memory entry: Fault message (for explanation see Read values 4 / Fault_m
3	1st fault_entry_rate		Read value	1. Memory entry: Frequency of occurrence (since initial operation)
4	1st fault entry		Read value	1st memory entry: source of occurrence
		0	-	is not known
		1	Mainboard	is the motherboard
		2	Cylinder 1	is the steam cylinder 1
		3	Cylinder 2	is the steam cylinder 2
		10	Relay_extension 1	is the relay board 1
		11	Relay_extension 2	is the relay board 2
		12	Relay_extension 3	is the relay board 3
		13	Relay_extension 4	is the relay board 4
		20	Cylinder_extension 1	is the expansion board 1
		21	Cylinder_extension 2	is the expansion board 2
		22	Cylinder_extension 3	is the expansion board 3
		23	Cylinder_extension 4	is the expansion board 4

Table of history layout (ctd.)

5	2nd fault_entry_date		Read value	2. Memory entry: Date/time
6	2nd fault_entry_message		Read value	2. Memory entry: Error message, see above
7	2nd fault_entry_rate	see: 02-1	Fault_message_unit Read value	2. Memory entry: Frequency of occurrence (since initial operation)
8	2nd fault entry		Read value	2nd memory entry: source of occurrence
9	3rd fault_entry_date	see: 07-4	1st fault entry Read value	3. Memory entry: Date/time
10	3rd fault_entry_message		Read value	3. Memory entry: Error message see above
11	3rd fault_entry_rate	see: 02-1	Fault_message_unit Read value	3. Memory entry: Frequency of occurrence (since initial operation)
12	3rd fault entry		Read value	3rd memory entry: source of occurrence
13	4th fault_entry_date	see: 07-4	1st fault entry Read value	4. Memory entry: Date/time
14	4th fault_entry_message		Read value	4. Memory entry: Error message see above
15	4th fault_entry_rate	see: 02-1	Fault_message_unit Read value	4. Memory entry: Frequency of occurrence (since initial operation)
16	4th fault entry		Read value	4th memory entry: source of occurrence
17	5th fault_entry_date	see: 07-4	1st fault entry Read value	5. Memory entry: Date/time
18	5th fault_entry_message		Read value	5. Memory entry: Error message see above
19	5th fault_entry_rate	see: 02-1	Fault_message_unit Read value	5. Memory entry: Frequency of occurrence (since initial operation)
20	5th fault entry		Read value	5th memory entry: source of occurrence
21	6th fault_entry_date	see: 07-4	1st fault entry Read value	6. Memory entry: Date/time
22	6th fault_entry_message		Read value	6. Memory entry: Error message see above
23	6th fault_entry_rate	see: 02-1	Fault_message_unit Read value	6. Memory entry: Frequency of occurrence (since initial operation)
24	6th fault entry		Read value	6th memory entry: source of occurrence
25	7th fault_entry_date	see: 07-4	1st fault entry Read value	7. Memory entry: Date/time
26	7th fault_entry_message		Read value	7. Memory entry: Error message see above
27	7th fault_entry_rate	see: 02-1	Fault_message_unit Read value	7. Memory entry: Frequency of occurrence (since initial operation)
28	7th fault entry		Read value	7th memory entry: source of occurrence
29	8th fault_entry_date	see: 07-4	1st fault entry Read value	8. Memory entry: Date/time
30	8th fault_entry_message		Read value	8. Memory entry: Error message see above
31	8th fault_entry_rate	see: 02-1	Fault_message_unit Read value	8. Memory entry: Frequency of occurrence (since initial operation)
32	8th fault entry		Read value	8th memory entry: source of occurrence
33	9th fault_entry_date	see: 07-4	1st fault entry Read value	9. Memory entry: Date/time
34	9th fault_entry_message		Read value	9. Memory entry: Error message see above
35	9th fault_entry_rate	see: 02-1	Fault_message_unit Read value	9. Memory entry: Frequency of occurrence (since initial operation)
36	9th fault entry		Read value	9th memory entry: source of occurrence
37	10th fault_entry_date	see: 07-4	1st fault entry Read value	10. Memory entry: Date/time
38	10th fault_entry_message		Read value	10. Memory entry: Error message see above
39	10th fault_entry_rate	see: 02-1	Fault_message_unit Read value	10. Memory entry: Frequency of occurrence (since initial operation)
40	10th fault entry		Read value	10th memory entry: source of occurrence
		see: 07-4	1st fault entry	

6.7 Screen 3 - Main menu (operator level)

After the operator level has been selected by entering the corresponding password (code 010), the main menu is displayed. It spans multiple screen pages and scroll icons are used to navigate between them.

Screen page 1 (of 3)

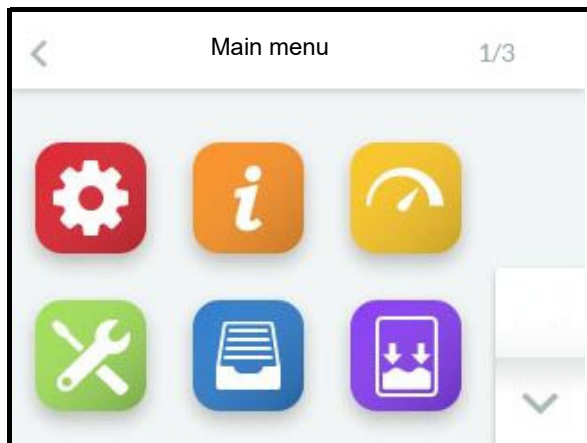

Screen page 3 (of 3)

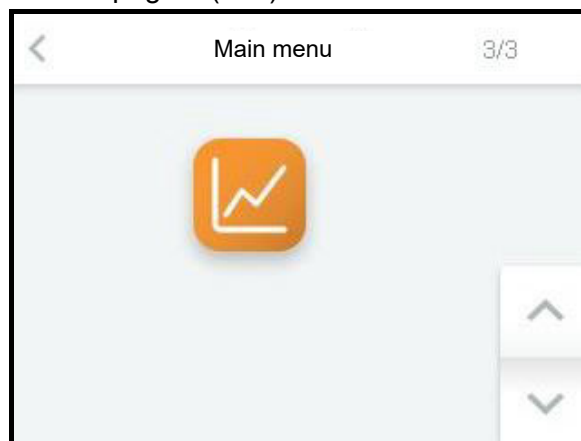

Screen page 2 (of 3)

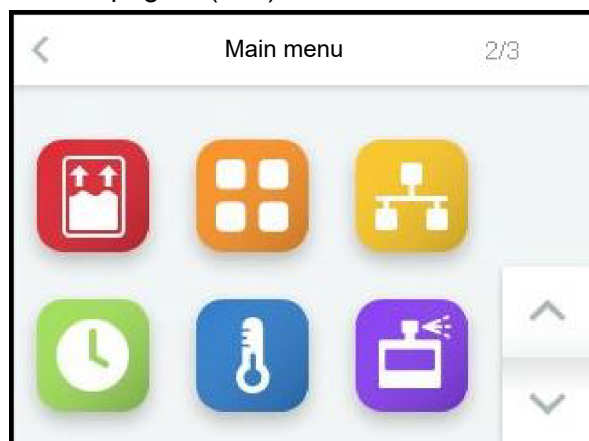

6.8 Operator level submenus

By tapping on the respective icon, the user accesses the screen page where the parameters of the respective group are available for selection, viewing or for making changes. The layout of the screen pages corresponds to the pages of the submenus of the user level (see Section 6.6).

The parameters available in the submenus are described in table form below (for explanations on the individual parameters see Section "Glossary").

Opening of submenu	
	Settings
	Reading values
	Control
	Service
	History
	Blow-down
	Filling
	Functions
	Communication interface
	Weekly timer
	SPA
	Essence
	Recording
	Cylinder extension (visible only if an extension board is present)
	Relay extension 1 (visible only if a relay board is present)
	Relay extension 2 (visible only if 2nd relay board is present)

6.8.1 Settings submenu



Table of settings parameters (operator level)

03: Settings

No.	Parameter	No.	Adjustment/value range Factory setting (FS) Bold min max FS			Meaning/Comment [] explains the term in the glossary →[] refers to a related explanation of the term
1	Language		Selection see: 01-1 Language			Selection of language
2	Date		DD.MM.YY			Set date
3	Time_of_day		HH:MM			Set time
4	Display_lighting_normal		5	100	100	Screen backlight in undimmed state
5	Delay_present_page		0	3600	300	Display duration for a certain screen page before return to the main screen in min
6	Display_lighting_dimmed		0	100	50	Screen brightness for dimmed state
7	Display_dim_after		0	3600	120	Switching of screen brightness of main screen to dimmed value after ... seconds. If an error has occurred or a status message is displayed, the main screen is not dimmed
8	Units		Selection			Selection of system of units
		0	SI			Units are displayed in the format of the SI system of units [8]
		1	Imperial			Units are displayed in the format of the imperial system of units [9]

6.8.2 Reading values submenu



The reading values submenu is no different to that of the user level. The reading values listed in table format in Section 6.6.2 are also available at the operator level.

6.8.3 Control submenu



Table of control parameters

05: Control

No.	Parameter	No.	Adjustment/value range			Meaning/Comment [] explains the term in the glossary ->[] refers to a related explanation of the term
			Min	Max	FS	
1	Control_settings		Selection see: 01-4 Control_settings			Combinations of control type and input signal type/range
2	Output_max.		25,0	100,0	100,0	The maximum output power [43] can be limited to between 25 and 100%
3	Δ Power_limitation		0,0	50,0	0,0	Reduction of the max. humidification output for the purpose of load shedding [101].
4	Output_signal		Selection			Mapping of the output signal [69] to an internal value
		0	Off			No mapping
		2	Control_sig_internal			Output signal is proportional to the internal actuator signal [42]
33	Damping_analog inputs		Selection			The attenuation for capacitive sensors is activated. Only possible with activated PI controller
		0	Off			Switch off attenuation
		1	On			Switch on attenuation

6.8.4 Service submenu



6.8.4.1 Monitoring and service messages

The components of the unit which wear due to operational reasons, including the steam cylinder(s), are monitored continuously when the unit is in operation. When a limit value is reached, the corresponding service message is displayed with reference to the cylinder. The service messages need to be reset after component replacement or cylinder maintenance.

The following **service messages** are set:

Steam amount

A steam amount in kg is specified in the "Steam amount_service" parameter and after this is reached, the message "Steam amount_counter" is issued.

In case of double cylinder units, the parameter entry applies to both cylinders. The service message differentiates between cylinder 1 and cylinder 2.

After the service has been carried out, the message has to be reset with "Service reset_cyl. 1" or "Service reset_cyl. 2" (or both).

For the assessment of the remaining steam amount until the next service is required, the reading values "Steam amount_until_service_cyl. 1" and "Steam amount_until_service_cyl. 2" (only for double cylinder units) are used.

Main contactors

For main contactors, the maximum number of switching cycles is specified by the manufacturer. When a limit value is reached, the corresponding service message is displayed. The main contactor must then be replaced and the message has to be reset by setting the "Main_contactor Kx_Reset" (x = 1...5) parameter.

Please note

When the service message was triggered for one of the main contactors, it is advisable to check the meter reading for the remaining main contactors using the "Kx_switching cycles_until msg" (x = 1...5) reading values.

Monitoring

The FlexLine control continuously monitors the proper functionality of the electrodes (only for ELDB), the blow-down pump(s) and the solenoid valve(s). If the preset functionality alarm thresholds are exceeded, messages regarding the status

- of the **electrodes** (only for ELDB) ("Warning_cyl. full") or
- the **blow-down pump(s)** ("Warning_pump") or
- the **solenoid valve(s)** ("Warning_valve")

are created.

Three sensitivity values can be selected for each of the alarm thresholds, where "Sensitivity 3" triggers the warning messages at the earliest point.

After the cause is resolved (e.g. cleaning the input filter of the solenoid valve when a "Warning_valve" message appears), the warning message disappears.

The three above-mentioned messages can also be turned off (see subsequent Section "Table of service parameters", parameters 22, 23, 24).

Table of service parameters

06: Service

No.	Parameter	No.	Adjustment/value range			Meaning/Comment [] explains the term in the glossary → [] refers to a related explanation of the term
			Factory setting (FS)	min	max	
1	Steam_amount_service		0	65535	4500	Preset steam volume (see [33]) in kg until service message is triggered. For double cylinder units, this setting applies to both cylinders
4	Service-reset_cyl. 1		Selection			Reset steam volume counter for cylinder 1 →[33]
		0	Off			No
		1	On			Yes
5	Steam_until_msg_cyl. 1		Read value			Remaining steam volume for cyl. 1 in kg until service message →[33] is triggered
7	Service-reset_cyl. 2		Selection			Reset steam volume counter for cylinder 2 →[33], double cylinder units only
		0	Off			No
		1	On			Yes
8	Steam_until_msg_cyl. 2		Read value			Remaining steam volume for cyl. 2 in kg until service message →[33] is triggered
12	Main_contactor_1_reset		Selection			Reset K1 counter for main contactor operating cycles →[34]
		0	Off			No
		1	On			Yes
13	K1_switching_cycles_until_msg.		Read value			Remaining operating cycles for K1 until service message →[34] is triggered
14	Main_contactor_2_reset		Selection			Reset K2 counter for main contactor operating cycles →[34]
		0	Off			No
		1	On			Yes
15	K2_switching_cycles_until_msg.		Read value			Remaining operating cycles for K2 until service message →[34] is triggered
16	Main_contactor_3_reset		Selection			Reset K3 counter for main contactor operating cycles →[34] (double cyl. units only)
		0	Off			No
		1	On			Yes
17	K3_switching_cycles_until_msg.		Read value			Remaining operating cycles for K3 until service message →[34] is triggered
18	Main_contactor_4_reset		Selection			Reset K4 counter for main contactor operating cycles →[34] (double cyl. units only)
		0	Off			No
		1	On			Yes
19	K4_switching_cycles_until_msg.		Read value			Remaining operating cycles for K4 until service message →[34] is triggered
20	Main_contactor_5_reset		Selection			Reset K5 counter for main contactor operating cycles →[34] (double cyl. units only)
		0	Off			No
		1	On			Yes
21	K5_switching_cycles_until_msg.		Read value			Remaining operating cycles for K5 until service message →[34] is triggered
22	Warning_cyl._full		Selection			Warning message about electrode burn-off (only for ELDB [77]) →[95]
		0	Off			No message
		1	Sensitivity 1			Threshold value 1 for message (lowest sensitivity)
		2	Sensitivity 2			Threshold value 2 for message (medium sensitivity)
		3	Sensitivity 3			Threshold value 3 for message (highest sensitivity)
23	Warning_pump		Selection			Warning message about functional performance of blow-down pump →[95]
		see: 06-22 Warning_cyl._full				
24	Warning_valve		Selection			Warning message about functional performance of solenoid valves →[95]
		see: 06-22 Warning_cyl._full				
26	Update_function		Read value			Status of update function [7]
		0	USB-stick_insert			USB stick is not inserted
		1	Loading			The parameter set which is saved on the stick is loaded
		2	Checking			The loaded parameter set is checked
		3	Update			The parameter set is updated
		4	Successful			The update was successful
		5	Data_not_valid			USB stick does not contain a parameter set or parameter set is not compatible

6.8.4.2 Procedure for parameter update

The information below explains how to work with the "Update_function" parameter (see parameter row 26 in the table above).

The update function makes it possible to overwrite parameter settings with a parameter set which is saved on an external USB stick. As a result, the operator can make a change without having to change the parameters by themselves. The modified parameter set can be provided by HygroMatik.

The procedure is as follows:

- » With the unit switched on, insert the USB stick into the socket on the mainboard.
- » Call up the "Update function" in the services submenu.

The status of the update process is displayed (see table). Its successful completion is indicated by the "Update successful" status message.

- » Switch the unit off and on again. The parameter set which has been loaded is activated.
- » To reload the parameter set at a later date if required (e.g. after a factory reset), the "ImportDone.txt" file on your USB stick must be deleted beforehand. To do so, the USB stick must be inserted in an external device (e.g. PC).

If the status "Invalid data" is output after the update operation, a compatible parameter set is not available on the USB stick.

The parameter set that is stored on a USB stick is always linked with a unit serial number and can only be used for this unit.

USB connection on mainboard

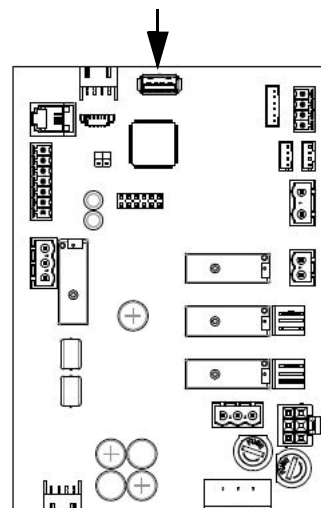

6.8.5 History submenu



The fault message history was already described for the user level in Section 6.6.3. There are no differences at the operator level.

6.8.6 Blow-down submenu



Table of blow-down parameters

08: Blow-down

No.	Parameter	No.	Adjustment/value range			Meaning/Comment [] explains the term in the glossary →[] refers to a related explanation of the term
			min	max	FS	
1	Full_blow-down_correction		-5	5	0	Correction value for frequency of full blow-down (+ = more frequently, - = less frequently) →[55]
2	Part_blow-down_correction		-5	5	0	Correction value for frequency of partial blow-down (+ = more frequently, - = less frequently) →[55]
3	Standby_blow-down		Selection			Full blow-down [58] for hygiene reasons, if there was no steam production for an extended period →[26]
		0	Deactivated			No stand-by blow-down
		1	Activated			Blow-down after waiting period
4	Standby_blow-down_interval		1	2880	1440	After the waiting period specified, the remaining water is pumped off if the interlock (safety) system [11] was opened during this period of time, i.e. no steam production took place →[26]
5	Blow-down_without_K1		Selection			Pumps without main contactor [75] in order to avoid triggering of residual current detector →[56]
		0	Deactivated			Main contactor [75] switched on during pumping
		1	Activated			Main contactor [75] switched off during pumping

6.8.7 Fill parameters submenu



Table of fill parameters

09: Filling

No.	Parameter	No.	Adjustment/value range			Meaning/Comment [] explains the term in the glossary →[] refers to a related explanation of the term
			min	max	FS	
1	Filling_pulsed		Selection			The filling process is not continuous, but intermittent →[54]
		0	Deactivated			Activated
		1	Activated			Not activated
2	Filling_pulsed_interval		1	10	2	Time interval in s, during which filling does not take place (filling pause)
3	Filling_pulsed_active		1	600	10	Duration of filling time in s until filling pause

6.8.8 Functions submenu



Table of function parameters

10: Functions

No.	Parameter	No.	Adjustment/value range			Meaning/Comment [] explains the term in the glossary →[] refers to a related explanation of the term
			Factory setting (FS)	Min	Max	
1	Standby-heating		Selection			The standby heating [16] keeps the water in the cylinder warm if no demand [5] is present
		0	Deactivated			Standby heating [16] switched off
		1	Activated			Standby heating [16] switched on
2	Standby-heating_interval		1	999	1	Pause time of standby heating [min]
3	Standby-heating_active		1	999	1	Heating time of standby heating [16] [s]
4	Dead_leg_flushing		Selection			Solenoid valve of the water inlet and pump/flushing valve are switched on and off in parallel for dead leg flushing [27].
		0	Deactivated			Flushing of dead-end line [27] is not carried out
		1	Activated			Perform dead leg flushing [27] as required (semi-automatic or fully automatic, depending on device/plant)
5	Dead_leg_flushing_interval		1	5760	1440	Waiting period until start of flushing of dead-end line [27] [min]
6	Dead_leg_flushing_active		1	600	90	Duration of flushing of dead-end line [27] [s]
7	Runtime_limitation		0	1440	0	Steam production is stopped after the time interval specified [min]; for resumption →[32]
8	Weekly_timer		Selection			Activation of weekly timer
		0	Off			Steam production runs continuously with the parameters preset
		1	On			Steam is generated in accordance with the settings made in the weekly timer submenu →[91]
9	Timer_mode		Selection			The timer function [18] is triggered with an external button
		0	Off			The timer function [18] is not available
		1	Steam_off			Steam production stops after the timer has elapsed
		2	ECO			The unit reverts to ECO mode [61] after the timer has elapsed
10	Timer_running_time		0	65535	0	The runtime of the timer is given in seconds
11	Password_remote		0	9999	0	Storage of a password with a maximum of 4 digits for remote access via the communication interface, input using the keyboard screen
12	Function_digital_input		Selection			Mapping of digital input function [98] to mainboard
		0	Off			Not used
		1	Push_button_light 1			Activated digital input [97] by a pushbutton [106] switches on light 1
		2	Push_button_light 2			Activated digital input [97] by a pushbutton [106] switches on light 2
		3	Push_button_light 3			Activated digital input [97] by a pushbutton [106] switches on light 3
		4	Push_button_light 4			Activated digital input [97] by a pushbutton [106] switches on light 4
		10	ECO			Activated digital input [97] by a pushbutton [106] switches ECO mode on
		20	Steam_boost			Activated digital input [97] by a pushbutton [106] triggers steam jet [60]
		30	Timer_start			Activated digital input [97] by a pushbutton [106] starts timer function [18]
		40	Power_limitation			Activated digital input [97] by a switch (NO) switches power limitation on for load shedding [101]
		61	°C_Begrenzer			
		62	Leakage_sensor			The activated digital input [97] monitors the (NC) contact of an external leakage detector. If the contact opens, an error message is shown on the display and humidification is switched off
		63	Sicherheitsabschaltung			
		70	Steam enable			The activated digital input[97] by means of a switch (NO)[102] enables steam production. Opening the switch interrupts steam production.
		80	Standby_blow-down			The digital input [97] activated with a button [106] starts a standby desludging process.
		81	Dead_leg_flushing			The digital input [97] activated with a button [106] starts a stub flush.
		90	Relay			The digital input [97] activated by a switch (NO) [102] activates a relay if this has been assigned.
		100	Water_inlet_pressure			
		101	Blowdown_delay			
13	Power_retention		0,0	50,0	0,0	Reduction of humidifier performance after target temperature has been reached, to proportion of maximum performance [%] entered here as power retention [66]
14	Control_curve		Selection			Behaviour during cold start or specification for special applications (only ELDB [77]), see [68]
		0	Energie-optimized			Current during cold start is 128% of rated current for fast heating
		1	Load-optimized			Current during cold start is 113% of the nominal current, to avoid overloading the supply network despite fast heating
		2	Process-optimized			Particularly fine control for critical applications
15	Delay_humidificat_notif.		0	3600	60	Delay of Humidifying message [s] →[74]

Continuation of function parameters

10: Functions

No.	Parameter	No.	Adjustment/value range			Meaning/Comment
			Factory setting (FS) Bold			
			Min	Max	FS	
16	Assignment_main_relay		Selection			The relay is energised for a message (M) or a switching function (S), if ...
		0	Collective_fault			There is any kind of error (M)
		1	Safety_interlock_open			The interlock (safety) system [11] is open (M)
		2	No_Demand			No demand [5] is present (M)
		3	Humidification			Steam production is in progress (M)
		4	Runtime_limitation			The unit has switched off steam production after the limitation of operating time was reached [32] (M)
		5	Remote_off			A remote shutdown was carried out via software command [12] (M)
		6	Safety_interlock_ELV			The interlock (safety) system [11] is switched via an additional relay (M)
		7	Safety_interlock_closed			The interlock (safety) system [11] is switched as standard (M)
		8	Humidification_off_delay			A dropout delay [74] is to be generated following humidification (S)
		9	Timer_steam_off			the timer function has stopped the steam production (M)
		10	Weekly_timer_steam_off			the weekly timer has stopped the steam production (M)
		11	Modbus			it is controlled directly by a Modbus command. (S)
		12	Standby_signal			the device has completed initialization and is not in error (M)
		13	Initialization			
		20	Digital_input_active			the digital input of the motherboard is activated (M)
		21	DigIn_relay extension board 1			the digital input of relay board 1 is activated (M)
		22	DigIn_relay extension board 2			the digital input of relay board 2 is activated (M)
		23	DigIn_cylinder ext. board 1			the digital input of the expansion board is activated (M)
		33	Solenoid_valve 2			Solenoid valve 2 is actuated (M)
		36	HyFlush			das HyFlush-MV über die Kontakte dieses Relais' geschaltet wird und die vollautomatische Sticheitungsspülung genutzt wird (S)
		38	Pressure_water_input_min			the minimum water inlet pressure is not reached.
		60	Pump_off			The blow-down pump is not actuated (M)
		61	Pump_on			The blow-down pump is actuated (M)
		62	Part_blow-down			A partial blow-down [21] is taking place (M)
		63	Full_blow-down			A full blow-down [22] is taking place (M)
		64	Dilution			A dilution [23] is taking place (only for ELDB [77]) (M)
		65	Max_current_blow-down			An overcurrent blow-down [24] is taking place (only for ELDB [77]) (M)
		66	Max_level_blow-down			A max. level blow-down [25] is taking place (only for HKDB [78]) (M)
		67	Standby_blow-down			A standby blow-down [26] is taking place (M)
		68	Dead_leg_flushing			An additionally installed relay is to be actuated, which switches the input solenoid valve for flushing the dead-leg line if the interlock (safety) system is not closed (S)
		69	Start_blow-down			A start blow-down [20] is taking place (M)
		70	Blowdown_cycle			
		90	Cylinder_full_cyl. 1			
		91	Cylinder_full_cyl. 2			
		120	Cylinder_1_step_1			Power level [63] 1 of cylinder 1 is active (only for HKDB [78]) (S). If this assignment was chosen ex-factory, no other assignment is possible.
		121	Cylinder_1_step_2			Power level [63] 2 of cylinder 1 is active (only for HKDB [78]) (S). If this assignment was chosen ex-factory, no other assignment is possible.
		122	Cylinder_2_step_1			Power level [63] 1 of cylinder 2 is active (only for HKDB double cylinder units) (S). If this assignment was chosen ex-factory, no other assignment is possible.
		123	Cylinder_2_step_2			Power level [63] 2 of cylinder 2 is active (only for HKDB double cylinder units) (S). If this assignment was chosen ex-factory, no other assignment is possible.
		124	Dry_level_cyl. 1			
		125	Dry_level_cyl. 2			
		240	Light 1			Light 1 is to be switched directly (S)
		241	Light 2			Light 2 is to be switched directly (S)
		242	Light 3			Light 3 is to be switched directly (S)
		243	Light 4			Light 4 is to be switched directly (S)
		244	Exhaust_fan 1			Steam bath fan 1 is active (S)
		245	Exhaust_fan 2			Steam bath fan 2 is active (S)
		246	Supply_fan 1			Steam bath fan 3 is active (S)
		247	Supply_fan 2			Steam bath fan 4 is active (S)
		248	Essence 1			Essence pump 1 is active (S)
		249	Essence 2			Essence pump 2 is active (S)
		250	Essence 3			Essence pump 3 is active (S)
		251	Essence 4			Essence pump 4 is active (S)
		252	ECO_active			Steam bath target temperature is switched to ECO mode [61] (M)
		253	Steam_boost_active			A steam jet [60] is triggered (M)
		254	Steam_boost_blocked			A further steam jet is blocked →[60] (M)
		255	Temp_threshold			The preset temperature threshold value [88] has been reached (M)
		256	Temp_control_active			the steam generator temperature control is active (M)
		270	Collective_service			A general service message is generated (M)
		271	Service_solenoid_valve			A service for one of the solenoid valves or the water supply line is required
		272	Service_blow-down_pump			A service for the blow-down pump is required (M)
		273	Service_steam_amount_cnt.			A service is required after the steam volume counter which is relevant for the service was reached (M)
		274	Service_main_contactor K1			A service is required after the max. operating cycles for K1 have been reached (M)
		275	Service_main_contactor K2			A service is required after the max. operating cycles for K2 have been reached (only for double cylinder units) (M)
		276	Service_main_contactor K3			A service is required after the max. operating cycles for K3 have been reached (only for double cylinder units) (M)
		277	Service_main_contactor K4			A service is required after the max. operating cycles for K4 have been reached (only for double cylinder units) (M)
		278	Service_main_contactor K5			A service is required after the max. operating cycles for K5 have been reached (only for double cylinder units) (M)
		284	Not used			The relay is not used and is not controlled.

10: Functions

No.	Parameter	No.	Adjustment/value range			Meaning/Comment
			Factory setting (FS) Bold			
			Min	Max	FS	
17	Assignment_relay K20		Selection			Relay 1 is one of the top-hat rail relays connected to the ST10.1 connector on the mainboard; assignment is same as for base relay
			see: 10-16 Assignment_main_relay			
18	Assignment_relay K21		Selection			Relay 2 is the second of the top-hat rail relays connected to the ST10.2 connector on the mainboard; assignment is same as for base relay
			see: 10-16 Assignment_main_relay			
19	Assignment_relay K22		Selection			Relay 3 is one of the top-hat rail relays connected to the ST10.2 connector on the mainboard; assignment is same as for base relay
			see: 10-16 Assignment_main_relay			
20	Assignment_relay K23		Selection			Relay 4 is the second of the top-hat rail relays connected to the ST10.2 connector on the mainboard; assignment is same as for base relay
			see: 10-16 Assignment_main_relay			

If there are no factory installed options, only contact ST03 on the basic relay is assigned the "collective fault" function. All other contacts are assigned the switching message "Not used".

6.8.9 Communication interface sub-menu



The communication interface is a serial RS485 computer interface for the remote control of the steam humidifier. With this computer interface, all control operations which can be carried out on the display can also be carried out by the building technology control system, for example.

Table of communication interface parameters

11: Communication

No.	Parameter	No.	Adjustment/value range			Meaning/Comment
			Factory setting (FS) Bold			
			Min	Max	FS	
1	Address		0	255	1	Address of the communication interface [13]
2	Baud_rate		Selection			Setting the baud rate
		3	9600			9600
		4	19200			19200
		6	38400			38400
3	Parity		Selection			Parity setting
		0	None			Without parity bit
		1	Odd			Odd parity bit
		2	Even			Even parity bit
4	Stop_bits		Selection			Number of stop bits
		0	1			1 stop bit
		1	2			2 stop bits
5	Modbus_timeout		0	60	20	Timeout in s for software control commands [12] through communication interface [13]
6	BACnet_MacID		1	127	1	Physical address of a BACnet device within the network (s. separate HygroMatik documentation)
7	BACnet_Instance		0	65535	1	Number for the unique addressing of an instance of a specific BACnet object (s. separate HygroMatik documentation)
8	BACnet_Master_max		1	127	127	Specification of the max. qty. of BACnet master devices within the network for avoidance of unnecessary polling actions (s. separate HygroMatik documentation)

6.8.10 Weekly timer submenu



The weekly timer is used to program two switching time ranges per day of the week, each defined by "Start time" and "End time". A set point temperature value and an essence can be assigned to each switching time range.

The activation of the timer can be carried out in the "Functions" submenu using parameter no. 8 ("Weekly timer"). The setting options are "On" and "Off".

Please note

When operating the control using the internal PI-controller and in weekly timer mode, the display of the temperature set value in the main display disappears during normal steam generation. In ECO mode, however, the set value specification remains visible.

Table of weekly timer parameters

12: Weekly timer

No. Parameter	No.	Adjustment/value range			Meaning/Comment [] explains the term in the glossary →[] refers to a related explanation of the term
		Min	Max	FS	
1 Mon_start_time 1		00:00	23:59	00:00	Start time 1 for Monday (1st period) →[91]
2 Mon_stop_time 1		00:00	23:59	00:00	End time 1 for Monday
3 Mon_essence 1		Selection			Essence selection for the 1st period on Monday
	0	Off			No essence
	1	Essence 1			Essence 1
	2	Essence 2			Essence 2
	3	Essence 3			Essence 3
	4	Essence 4			Essence 4
4 Mon_temp. 1		20,0	49,0	45,0	Steam bath target temperature [°C] for the 1st period on Monday
6 Mon_start_time 2		00:00	23:59	00:00	Start time 2 for Monday (2nd period) →[91]
7 Mon_stop_time 2		00:00	23:59	00:00	End time 2 for Monday
8 Mon_essence 2		Selection			Essence selection for the 2nd period on Monday
	see: 12-3 Mon_essence 1				
9 Mon_temp. 2		20,0	49,0	45,0	Steam bath target temperature for the 2nd period on Monday

The table only shows the possible parameter settings for Monday. The parameters for the rest of the weekdays (Tuesday to Sunday) can be programmed in the same way.

6.8.11 SPA submenu



Table of SPA parameters

13: SPA

No.	Parameter	No.	Adjustment/value range			Meaning/Comment [] explains the term in the glossary →[] refers to a related explanation of the term
			Factory setting (FS)	Min	Max	
1	Temp_set_value		20,0	49,0	45,0	Set value [3] of steam bath temperature in °C
3	ΔTemp_steam_off		0,1	5,0	0,5	The steam production is switched off when (temperature set value + Δtemp_steam_off) has been reached; setting in K (Kelvin)
4	ΔTemp_max.		1,0	10,0	10,0	Temperature set value [3] plus Δ temp_max. results in absolute max. temperature [41], at which the unit switches off for safety reasons; setting in K (Kelvin)
5	Steam_boost_blocking		60	600	60	Interval until the next steam jet is possible after a steam jet →[60]
6	Steam_boost_duration		0	300	20	Duration of a steam jet →[60]
7	ΔTemp_steam_boost		1,0	5,0	1,0	Set temperature increase at steam boost activation →[60]; setting in K (Kelvin)
8	Light_1_initial_state		Selection			Determines the initial state of light 1 when unit is switched on
		0	Off			Light switched off
		1	On			Light switched on
9	Light_2_initial_state		Selection			Determines the initial state of light 2 when unit is switched on
		0	Off			Light switched off
		1	On			Light switched on
10	Light_3_initial_state		Selection			Determines the initial state of light 3 when unit is switched on
		0	Off			Light switched off
		1	On			Light switched on
11	Light_4_initial_state		Selection			Determines the initial state of light 4 when unit is switched on
		0	Off			Light switched off
		1	On			Light switched on
12	Fan_run-on		0	120	0	Delay time [82] of steam bath fans in min
13	Exhaust_fan1_mode		Selection			Operating mode of exhaust fan 1
		0	Off			Off
		1	On			Continuous operation, if unit control switch is in pos. I
		2	Automatic			Exhaust fan is switched on when the temperature set value [3] has been reached and switched off again when (temperature set value - exhaust_fan1_Δ temp.) has been reached
14	Exhaust_fan1_Δ temp.		0,0	5,0	0,5	Steam bath exhaust fan 1 is switched off when (temperature set value [3] + exhaust_fan1_Δ temp. has been reached); setting in K (Kelvin)
15	Exhaust_fan2_mode		Selection			Operating mode of exhaust fan 2
		0	Off			Off
		1	On			Continuous operation, if unit control switch is in pos. I
		2	Automatic			The exhaust fan is switched on when the temperature set value [3] has been reached and switched off again when (target temperature + exhaust_fan2_Δ temp.) has been reached
16	Exhaust_fan2_Δ temp.		0,0	5,0	0,5	Exhaust fan 2 is switched off when (temperature set value [3] + exhaust_fan2_Δ temp. has been reached); setting in K (Kelvin)
17	Supply_fan1_mode		Selection			Operating mode of supply fan 1
		0	Off			Off
		1	On			Continuous operation, if unit control switch is in pos. I
		2	Automatic			Supply fan 1 runs during steam production and is switched off when (steam bath temperature set value + supply_fan1_Δ temp.) has been reached
18	Supply_fan1_Δ temp.		0,0	5,0	0,5	Temperature difference above set value which must be achieved for supply fan 1 to be switched off; setting in K (Kelvin)
19	Supply_fan2_mode		Selection			Operating mode of steam bath fan 2
		0	Off			Off
		1	On			Continuous operation, if unit control switch is in pos. I
		2	Automatic			Supply fan 2 runs during steam production and is switched off when (steam bath temperature set value + supply_fan2_Δ temp.) has been reached
20	Supply_fan2_Δ temp.		0,0	5,0	0,5	Exhaust fan 2 is switched off when (temperature set value [3] + exhaust_fan2_Δ temp. has been reached); setting in K (Kelvin)
21	ΔTemp_ECO		0,0	20,0	10,0	The temperature set value [3] is lowered by the amount entered in ΔTemp_ECO [52] in K (Kelvin) when ECO is enabled
22	Correction_temp.-signal		-5,0	5,0	0,0	Used for the adjustment of the temperature sensor; setting in K (Kelvin)
23	Temperature_notification		0,0	90,0	45,0	Used to specify a temperature threshold value [92] in °C. When this is reached, a relay is energised

Continuation of SPA parameters

13: SPA

No.	Parameter	No.	Adjustment/value range			Meaning/Comment
			Factory setting (FS) Bold			
			Min	Max	FS	
25	Sensor_2_connection		Selection			Selection of the input for the connection of 2nd temperature sensor →[45] Only 1 temperature sensor connected 2nd temperature sensor connected to the expansion board 2nd temperature sensor connected to the relay board
		0	Off			
		1	Cylinder_extension			
		2	Relay_extension 1			
26	Temperature_measurement		Selection			Type of measurement processing →[45] Averaging the measurements of both temperature sensors Error message in case of deviation
		0	Average			
		1	Deviation			
27	Sensor_1_weighting		0	100	50	Weighting of the measurements of both temperature sensors →[45]
28	Sensors_deviation		1,0	10,0	5,0	Specification of the deviation of temperature measurement 2 from temperature measurement 1, at which an error message is to be triggered →[45] in K (Kelvin)
29	PI-controller_gain		0,5	100,0	5,0	Proportional part of PI controller
30	PI-controller_integral		0	100	10	Integral part of PI controller

6.8.12 Essence submenu



Table of essence parameters

14: Essence

No.	Parameter	No.	Adjustment/value range			Meaning/Comment
			Factory setting (FS) Bold			
			min	max	FS	
1	Essences_selection		Selection			Selection of essence pump
			see: 12-3 Mon_essence 1			
2	Intensity_essence 1		0	10	5	Intensity [80] of the essence injection of essence pump 1
3	Intensity_essence 2		0	10	5	Intensity [80] of the essence injection of essence pump 2
4	Intensity_essence 3		0	10	5	Intensity [80] of the essence injection of essence pump 3
5	Intensity_essence 4		0	10	5	Intensity [80] of the essence injection of essence pump 4
14	ΔTemp_essence		1.0	30.0	25.0	Essence injection is enabled at steam bath temperature = (temperature set value - ΔTemp_essence) [K]
16	Essence_status		Read value			Status of essence injection (read values)
		0	Off			No essence injection
		1	Essence 1			Essence injection via pump 1
		2	Essence 2			Essence injection via pump 2
		3	Essence 3			Essence injection via pump 3
		4	Essence 4			Essence injection via pump 4
		14	Dispensing_Pause			The essence injection is in a pause interval
		15	Dispensing_Pause			The essence injection is in a pause interval
		16	Dispensing_Pause			The essence injection is in a pause interval
		17	Wait_temperature			Injection only takes place when the target temperature has been reached
		18	Wait_humidity			Injection only takes place when the target humidity has been reached
		19	Wait_steam			Injection only takes place when steam is also produced
17	Essence_pause		Read value			The pause time between the essence injection operations
18	Essence_active		Read value			The duration of an essence injection process

6.8.13 Recording submenu



The control can record 10 data sets internally on a rolling basis ("Recording" submenu, parameter 1 set to "ON"). Snapshots of the unit status are carried out at intervals of 10 s, which can be helpful for troubleshooting. When all memory slots are filled, a new data set overrides the oldest entry. A stored data set is retained for maximum of 7 days.

The complete recording [93] can be saved to a USB stick with FAT32 formatting.

For saving, pls. proceed as follows:

- » Call up recording submenu.
- » Insert USB stick in connector on mainboard (s. drawing below).
- » Set parameter „Saving_start“ (2) to „On“. Saving starts automatically. Then, parameter „Saving_start“ returns to the „Off“-state.

USB connection on mainboard

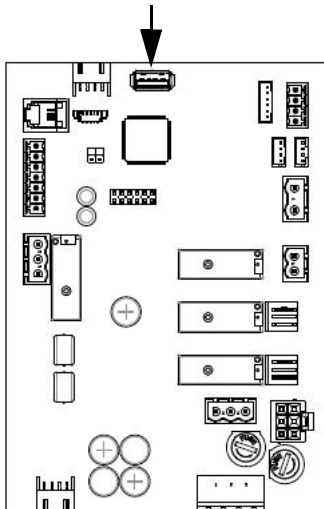

The **status** can be checked by calling up the "Saving status" parameter (4). "Enabled" means that the write operation is active.

The entire storage can be **deleted** using the "Delete recording" parameter (5).

Please note

During the erasing of the recording memory, the display possibly shows a „?“ since no access to the unit parameters is made.

A data set consists of the following values:

No.	Value	only
1	Steam_actual_unit	
2	Steam_actual_Cyl. 1	DZG
3	Steam_actual_Cyl. 2	DZG
4	Status_unit	
5	Status_cyl. 1	
6	Status_cyl. 2	DZG
7	Fault message_unit	
8	Fault message_cyl. 1	
9	Fault message_cyl. 2	DZG
10	Safety interlock_open	
11	Demand	
12	Steam_output_max.	
13	Current_actual_Cyl. 1	ELDB
14	Current_actual_Cyl. 2	ELDB DZG
15	Water_level_cyl. 1	HKDB
16	Water_level_cyl. 2	HKDB DZG
21	Temp._actual value	
22	Temp._actual_value 1	2S
23	Temp._actual_value 2	2S
24	Temp._set value	

Legend:

- ELDB = Electrode Steam Humidifier
- HKDB = Heater Element Steam Humidifier
- DZG = Double Cylinder Unit
- 2S = Device featuring 2 Temperature Sensors

Table of recording functions

16: Recording

No.	Parameter	No.	Adjustment/value range Factory setting (FS) Bold min max FS	Meaning/Comment [] explains the term in the glossary ->[] refers to a related explanation of the term
1	Recording		Selection	Recording [93] of parameter sets
		0	Deactivated	No recording
		1	Activated	Start recording
2	Saving_start		Selection	Saving of the existing recording on a USB stick
		0	Off	No action
		1	On	Start saving process
3	Saving_abort		Selection	Cancel saving
		0	Off	No action
		1	On	Cancel saving process
4	Saving_status		Read value	Status of saving process
		0	Deactivated	Saving not possible
		1	Activated	Saving is enabled
5	Recording_delete		Selection	Delete recording
		0	Off	No action
		1	On	Delete recording

6.8.14 Cylinder extension submenu



The icon is only visible in the main menu if a cylinder extension board is present.

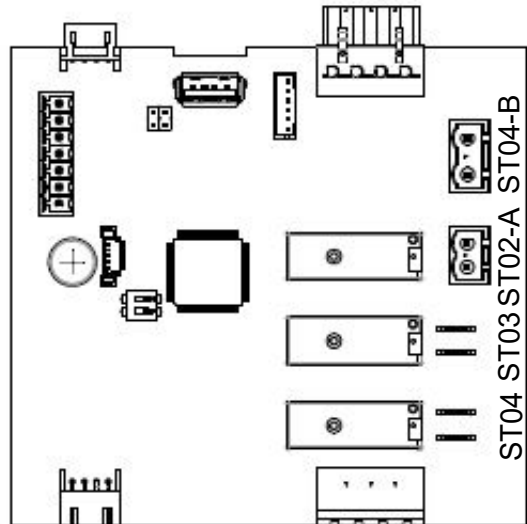

Table of control input parameters

17: Cylinder_extension

No.	Parameter	No.	Adjustment/value range			Meaning/Comment
			min	max	FS	
1	Digital_input_function		Selection			Assignment of the digital input function [98] of the digital input [97] on the cylinder extension board
			see: 10-12 Function_digital_input			
8	V_Signal		Read value			Voltage signal measured on terminal ST0505
9	V_Signal_%		Read value			Processed input signal corresponding to measured voltage signal on terminal ST0505 [%]
10	mA_Signal		Read value			Current signal measured on terminal ST0506
11	mA_Signal_%		Read value			Processed input signal corresponding to measured current signal on terminal ST0506 [%]
12	Ω_Signal		Read value			Resistance signal measured on terminal ST0507
13	Ω_Signal_%		Read value			Processed input signal corresponding to measured resistance signal on terminal ST0507 [%]
14	°C-Signal		Read value			Temperature signal measured on terminal ST0507
15	Digital_input		Read value			Current state of digital input [97] on terminal ST0508
		0	Off			No switching signal
		1	On			Switching signal present

6.8.15 Relay extension 1 submenu



The icon is only visible in the main menu if relay extension 1 has been activated. The assignment of the respective relays and the function definition of the digital input present on the relay card can be made here.

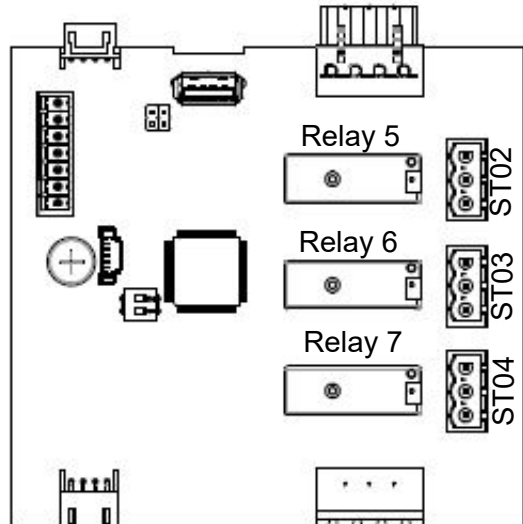

Relay designations on relay extension 1 p.c.b.

Table of control input parameters and possible relay assignments

18: Relay extension 1

No.	Parameter	No.	Adjustment/value range			Meaning/Comment [] explains the term in the glossary → [] refers to a related explanation of the term
			Factory setting (FS)	Bold	FS	
1	Assignment_relay ST02		Selection			Occupancy selection as for basic relay (see submenu Functions, 16)
			see: 10-16	Assignment_main_relay		
2	Assignment_relay ST03		Selection			Occupancy selection as for basic relay (see submenu Functions, 16)
			see: 10-16	Assignment_main_relay		
3	Assignment_relay ST04		Selection			Occupancy selection as for basic relay (see submenu Functions, 16)
			see: 10-16	Assignment_main_relay		
4	Digital_input_function		Selection			Mapping of the digital input function [98] to relay board 1
			see: 10-12	Function_digital_input		
11	V_Signal		Read value			Voltage signal measured on terminal ST0505
12	V_Signal_%		Read value			Processed input signal corresponding to measured voltage signal on terminal ST0505 [%]
13	mA_Signal		Read value			Current signal measured on terminal ST0506
14	mA_Signal_%		Read value			Processed input signal corresponding to measured current signal on terminal ST0506 [%]
15	Ω_Signal		Read value			Resistance signal measured on terminal ST0507
16	Ω_Signal_%		Read value			Processed input signal corresponding to measured resistance signal on terminal ST0507 [%]
17	°C-Signal		Read value			Temperature signal measured on terminal ST0507
18	Digital_input		Read value			Current state of digital input [97] on terminal ST0508
		0	Off			No switching signal
		1	On			Switching signal present

6.8.16 Relay extension 2 submenu



The icon is only visible in the main menu if relay extension 2 has been activated. The assignment of the respective relays and the function definition of the digital input present on the relay card can be made here.

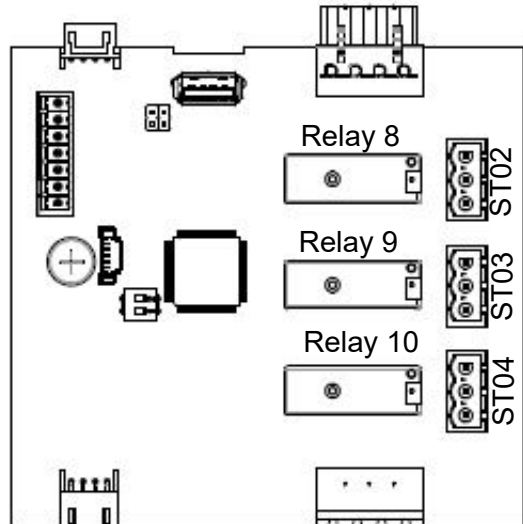

Relay designations on relay extension 2 p.c.b.

Table of control input parameters and possible relay assignments

19: Relay_extension 2

No.	Parameter	No.	Adjustment/value range			Meaning/Comment [] explains the term in the glossary -> [] refers to a related explanation of the term
			Factory setting (FS)	Bold	min max FS	
1	Assignment_relay ST02		Selection			Occupancy selection as for basic relay (see submenu Functions, 16)
			see: 10-16 Assignment_main_relay			
2	Assignment_relay ST03		Selection			Occupancy selection as for basic relay (see submenu Functions, 16)
			see: 10-16 Assignment_main_relay			
3	Assignment_relay ST04		Selection			Occupancy selection as for basic relay (see submenu Functions, 16)
			see: 10-16 Assignment_main_relay			
4	Digital_input_function		Selection			Mapping of the digital input function [98] to relay board 1
			see: 10-12 Function_digital_input			
11	V_Signal		Read value			Voltage signal measured on terminal ST0505
12	V_Signal_%		Read value			Processed input signal corresponding to measured voltage signal on terminal ST0505 [%]
13	mA_Signal		Read value			Current signal measured on terminal ST0506
14	mA_Signal_%		Read value			Processed input signal corresponding to measured current signal on terminal ST0506 [%]
15	Ω_Signal		Read value			Resistance signal measured on terminal ST0507
16	Ω_Signal_%		Read value			Processed input signal corresponding to measured resistance signal on terminal ST0507 [%]
17	°C-Signal		Read value			Temperature signal measured on terminal ST0507
18	Digital_input		Read value			Current state of digital input [97] on terminal ST0508
		0	Off			No switching signal
		1	On			Switching signal present

6.9 Screen 4 - Unit information

After a fault or a service message has occurred, a display which provides information about the type of message appears in the main display instead of the HygroMatik logo. The content of the messages is described in Section 7.

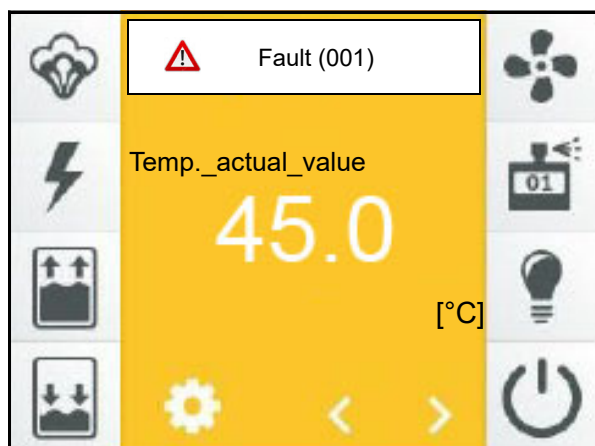

Tapping on this display field calls up the unit info screen which extends over several screen pages and contains comprehensive unit data. As an example, one possible first screen page is shown here:

02: Information	
01: Fault message_unit	Plug_ST09
02: Fault_message_cyl. 1	Plug_ST09
04: Service_message_cyl. 1	No message
06: Model	FLE20-AA10

The content of the screen pages is provided in the table in the next section.

Entries on the unit info screen

02: Information

No.	Parameter	Adjustment/value range			Meaning/Comment
		Min	Max	FS	
1 Fault_message_unit					
		Read value			List of possible unit fault messages
0	No_fault				No fault
1	Plug_ST09				The plug for the current transformer (ELDB) [77] or the level control (HKDB) [78] is not attached
2	Cylinder_extension 1				There is a problem with the expansion board 1
6	Relay_extension 1				There is a problem with relay board 1
7	Relay_extension 2				There is a problem with relay board 2
11	Plug_ST06				Connector ST06 on the expansion board is not plugged in.
12	Leakage_sensor				The external leakage detector connected to the DI has been activated (option)
22	Input_current_min.				Minimum value of current input not plausible
24	Input_resistance_OC				Minimum value of resistance input/NTC input not plausible
25	Input_resistance_SC				Maximum value of resistance input/NTC input not plausible
29	Internal				System fault
30	Filling_valve 1				Fault solenoid valve 1 [19]
32	Filling_valve 1 a. 2				Fault solenoid valve 1 and solenoid valve 2 [19]
61	Part_blow-down				Partial blow-down [21] not successful
62	Full_blow-down				Full blow-down [22] was not successful
63	Blow-down_dilution				Dilution [23] was not successful (only for ELDB [77])
64	Max._current_blow-down				Overcurrent blow-down [24] was not successful (only for ELDB [77])
65	Max._level_blow-down				Max. level blow-down [25] was not successful (only for HKDB [78])
66	Standby_blow-down				Stand-by blow-down [26] was not successful
67	Start_blow-down				Start blow-down [20] not successful
90	Cylinder_full				Sensor electrode reports cylinder full status [38] for over 60 min (only for ELDB [77])
91	Current_measurement				Value provided by current measurement not plausible (only for ELDB [77])
92	Main_contactor_current				A current is measured for at least 15 s, even though the main contactor [72] is not actuated (only for ELDB [77])
93	Main_contactor_cyl_full				A cylinder full status [38] was detected for at least 15 s, even though the main contactor [72] is not actuated (only for ELDB [77])
97	Zyl._Vollstand_Sensor				A thermo sensor [31] has been triggered (only for HKDB [78])
120	Thermoswitch				Value provided by level control [39] not plausible (only for HKDB [78])
121	Water_level_sensor				Max. level [40] was reached 5 times in a row during filling (only for HKDB [78])
122	Max.-level				
123	Steam_down_time				Despite a current feed to the radiators, the water level has not changed in the period specified →[53] (only for HKDB [78])
124	Relay_main_contactor				The relay for the control of the main contactor is not functioning correctly
240	Temp_sensor_miss				Temperature sensor, cable or input level defective with error pattern High resistance
241	Temp_sensor_broken				Temperature sensor, cable, or input level defective with error pattern Short circuit
242	Temperature_max				Max. temperature [41] exceeded
243	Temp_sensor_2_miss				Temperature sensor 2, cable or input level defective with error pattern High resistance
244	Temp_Sensor_2_broken				Temperature sensor 2, cable or input level defective with error pattern Short circuit
245	Temp_deviation				The two temperature sensors report different results
2 Fault_message_cyl. 1					
		Read value			List of possible fault messages for cylinder 1 (see Fault_message_unit)
0	No_fault				No fault
1	Plug_ST09				The plug for the current transformer (ELDB) [77] or the level control (HKDB) [78] is not attached
29	Internal				System fault
30	Filling_valve 1				Fault solenoid valve 1 [19]
32	Filling_valve 1 a. 2				Fault solenoid valve 1 and solenoid valve 2 [19]
61	Part_blow-down				Partial blow-down [21] not successful
62	Full_blow-down				Full blow-down [22] was not successful
63	Blow-down_dilution				Dilution [23] was not successful (only for ELDB [77])
64	Max._current_blow-down				Overcurrent blow-down [24] was not successful (only for ELDB [77])
65	Max._level_blow-down				Max. level blow-down [25] was not successful (only for HKDB [78])
66	Standby_blow-down				Stand-by blow-down [26] was not successful
67	Start_blow-down				Start blow-down [20] not successful
90	Cylinder_full				Sensor electrode reports cylinder full status [38] for over 60 min (only for ELDB [77])
91	Current_measurement				Value provided by current measurement not plausible (only for ELDB [77])
92	Main_contactor_current				A current is measured for at least 15 s, even though the main contactor [72] is not actuated (only for ELDB [77])
93	Main_contactor_cyl_full				A cylinder full status [38] was detected for at least 15 s, even though the main contactor [72] is not actuated (only for ELDB [77])
97	Zyl._Vollstand_Sensor				A thermo sensor [31] has been triggered (only for HKDB [78])
120	Thermoswitch				Value provided by level control [39] not plausible (only for HKDB [78])
121	Water_level_sensor				Max. level [40] was reached 5 times in a row during filling (only for HKDB [78])
122	Max.-level				
123	Steam_down_time				Despite a current feed to the radiators, the water level has not changed in the period specified →[53] (only for HKDB [78])
124	Relay_main_contactor				The relay for the control of the main contactor is not functioning correctly
3 Fault_message_cyl. 2					
		Read value			List of possible fault messages for cylinder 2 (see Fault_message_unit)
		see: 02-2 Fault_message_cyl. 1			

Entries on the unit info screen (ctd.)

No.	Parameter	No.	Adjustment/value range			Meaning/Comment
			Factory setting (FS)	Min	Max	
4	Service_message_unit		Read value			Service message unit
		0	No_service_msg.			A service is not required
		1	Steam_amount_counter			A unit service is required due to the steam volume counter
		2	Cycles_main_contactor 1			The maximum number of operating cycles for K1 has been reached and a Service_main_contactor [34] is required
		3	Cycles_main_contactor 2			The maximum number of operating cycles for K2 has been reached and a Service_main_contactor [34] is required
		4	Cycles_main_contactor 3			The maximum number of operating cycles for K3 has been reached and a Service_main_contactor [34] is required
		5	Cycles_main_contactor 4			The maximum number of operating cycles for K4 has been reached and a Service_main_contactor [34] is required
		6	Cycles_main_contactor 5			The maximum number of operating cycles for K5 has been reached and a Service_main_contactor [34] is required
		12	Warning_electrodes			The condition of the electrodes will require a replacement shortly (only for ELDB [77]) →[95]
		13	Warning_pump			In the area of the blow-down pump and/or the piping, there are indications that maintenance requirements are starting to develop →[95]
		14	Warning_valve			At a solenoid valve and/or the piping, there are indications that maintenance requirements are starting to develop →[95]
		17	Power_retention			An observed increase in the steam bath temperature may be due to the setting of the maintenance performance
		22	°C_Limiter_triggered			Der an den DI angeschlossene externe STB des TF106 hat ausgelöst(Option)
5	Service_message_cyl. 1		Read value			List of service messages for cylinder 1
			see: 02-4 Service_message_unit			
6	Service_message_cyl. 2		Read value			List of service messages for cylinder 2
			see: 02-4 Service_message_unit			
7	Model		Read value			Type designation of unit
8	Unit_name		Read value			Unit name [90], can be selected by the customer, if required
9	Serial_number		Read value			Serial_number
10	Date_of_manufacturing		Read value			Date_of_manufacturing
11	Software_version		Read value			Software version of control
12	Production_total_time		Read value			Total duration of steam production since initial operation (specified in days/months/years/hours/minutes)
13	Unit_total_runtime		Read value			The total runtime of the unit since its first connection to the power supply (specified in days/months/years/hours/minutes)
14	Steam_amount_total_cyl. 1		Read value			Entire steam volume of cylinder 1 [kg] produced since initial operation
15	Steam_amount_total_cyl. 2		Read value			Entire steam volume of cylinder 2 [kg] produced since initial operation (double cylinder units only)
18	Service_Reset		Selection			Reset all service messages?
		0	Off			No
		1	On			Yes

7. Faults and service messages

7.1 Fault handling

In case of a fault, steam production stops. Instead of the HygroMatik logo in the main display, a display panel appears with a warning sign, the message "Fault" and the fault codes in brackets:

e.g.:







By touching the fault message, the unit info screen opens, which contains the plain text fault message and information about the unit, as well as the unit status.





With most fault messages, one or several icons also flash, which makes it possible to initially narrow down the cause of the fault.

7.1.1 Table of fault messages, possible causes and countermeasures



These icons are flashing	Fault code	Fault message	Possible cause	Measure
	001	Plug_ST09 The plug for the current or water level measurement is not attached.	<ul style="list-style-type: none"> • Plug sits not firmly or is not in place 	<ul style="list-style-type: none"> • Check plug and attach if required
	002	Cylinder_extension Extension board is not detected by the software	<ul style="list-style-type: none"> • P.c.b. connection not o.k. • P.c.b. not present or defective • CAN bus addressing not correct 	<ul style="list-style-type: none"> • Check firm connection of boards • Connect board, replace board if defective • Check DIP switch settings on extension board (see fig. in section 4.4).
	006 007	Relay_extension 1 Relay:extension 2 Relay board(s) not detected by the software	<ul style="list-style-type: none"> • P.c.b. connection(s) not o.k. • P.c.b. (s) not present or defective • CAN bus addressing not correct 	<ul style="list-style-type: none"> • Check firm connection of boards • Connect board(s), replace board(s) if defective • Check DIP switch settings on relay boards (s. fig. in section 4.5).
	029	Internal	<ul style="list-style-type: none"> • Mainboard is defective 	<ul style="list-style-type: none"> • Replace mainboard

These icons are flashing	Fault code	Fault message	Possible cause	Measure
	030 032	Filling_valve 1 Filling_valve 1 a. 2 Filling was not successful, i.e. the expected filling level was not achieved after a device-specific time (15 - 45 min)	<ul style="list-style-type: none"> • Solenoid valve or supply line contaminated or defective • Solenoid defective • Water supply not opened • Solenoid valve electrically not driven <ul style="list-style-type: none"> - electrical cabling not o.k. - Mainboard relay not energised • Steam hose not laid with sufficient incline/decline resulting in a water bag obstructing steam flow. Steam builds up pressure in steam cylinder and pushes water towards drain • Blockage in steam pipe impedes the steam flow. The steam builds up pressure in the cylinder and presses the water into the drain. • L3 phase break-down • Main contactor does not switch phase L3 	<ul style="list-style-type: none"> • Clean water supply line and/or solenoid valve; replace solenoid valve, if defective • Make measurement on solenoid; replace solenoid valve, if defective • Open water supply - Check electrical cable and replace, if required - Measure voltage on circuit board terminal 11 against N; replace mainboard, if required • Check steam hose layout. Eliminate water bag. • Remove blockage in steam pipe • Reestablish L3 phase feeding • Replace main contactor

These icons are flashing	Fault code	Fault message	Possible cause	Measure
	<p>061 062 063 064 065 066 067</p>	<p>Blow-down fault, concerning: Part_blow-down Full_blow-down Blow-down_dilution (only ELDB) Max._current blow-down (only ELDB) Max._level blow-down (only HKDB) Standby_blow-down Start_blow-down (only HKDB)</p> <p>The respective blow-down was not successful.</p>	<ul style="list-style-type: none"> • Blow-down pump is not driven - electrical wiring not o.k. - Mainboard relay is not energised • Blow-down pump defective • Blow-down pump is working but water is not drained (i.e. cylinder drain is blocked) • Blow-down pump blocked by scale deposits 	<ul style="list-style-type: none"> - Check wiring and replace, if required - Measure voltage on circuit board terminal 10 against N, if required, change board • Replace blow-down pump • Completely clean steam cylinder and base to preclude renewed short-term clogging • Check blow-down pump, drain system and cylinder for scale deposits and clean
	<p>090</p>	<p>Cylinder_full (only ELDB) The sensor electrode consistently reports cylinder full status for 60 min</p>	<ul style="list-style-type: none"> • Low or widely fluctuating water conductivity • Electrodes worn out • No electrode cable run through current transducer • Salt bridges in steamcylinder upper part • Foaming (when softened water is used) 	<ul style="list-style-type: none"> • Check feed water quality; consult your expert dealer, if required • Replace electrodes • Run one phase through the current transducer • Clean • Increase blending rate (bigger raw water proportion)
 	<p>091</p>	<p>Current_measurement (only ELDB) The current transducer reading ist not correct</p>	<ul style="list-style-type: none"> • Plug is not seated properly on mainboard • Current transducer defective 	<ul style="list-style-type: none"> • Check plug seating • Replace current transducer

These icons are flashing	Fault code	Fault message	Possible cause	Measure
	092	Main_contactor_current (only ELDB) A current is measured though the main contactor is not driven.	<ul style="list-style-type: none"> • Main contactor contact sticks 	<ul style="list-style-type: none"> • Replace main contactor
	093	Main_contactor_cyl._full (only ELDB) „Cylinder full“ is detected though the main contactor is not driven.	<ul style="list-style-type: none"> • Main contactor contact sticks 	<ul style="list-style-type: none"> • Replace main contactor
	120	Thermal switch (HKDB only) One of the thermal switches has tripped.	<ul style="list-style-type: none"> • Thermostat on steam cylinder cover has tripped due to lime coating on heating element • Capillary tube defective • Thermo switch on solid state relay has triggered due to blocked ventilation • Blockage in a connection hose (see no. 21/22 in the exploded view in the main manual) leads to incorrect water level detection, which can cause the thermal switch to trip. 	<ul style="list-style-type: none"> • Switch off power supply. Remove lime coating. Allow cool-down of steam cylinder. Push-back unblocking pin on thermostat with needle-nose pliers or a screwdriver • Replace thermostat • Switch off unit. Allow cool-down of heat sink. Remove blockage. Ensure unobstructed ventilation. Restart humidifier operation. • Replace the blocked connection hose. Switch the device on again.
	121	Water_level_sensor (only HKDB) The water sensor reading is not plausible.	<ul style="list-style-type: none"> • Water sensor is defective • Connecting hoses blocked 	<ul style="list-style-type: none"> • Replace water sensor • Clean hoses





These icons are flashing	Fault code	Fault message	Possible cause	Measure
	122	<p>Max.-level (only HKDB)</p> <p>Water level has reached its maximum 5x in one single steam production phase</p>	<ul style="list-style-type: none"> • Excessive air pressure in duct has impact on water in steam cylinder via steam hose. Water is pressed into drainage • Solenoid valve closing action imperfect. Cylinder water level rises though solenoid valve is not energised • Solenoid valve is permanently energised (water intake stops when unit is switched off) • Large amounts of residues influence or restrict cyclic blow-down. The additional water introduction caused by the optional HyFlush rinse device may cause the max. level fault 	<ul style="list-style-type: none"> • Reduce air pressure, check steam hose for blockages • Check solenoid valve • Relay contacts on mainboard stick. Measure voltage across terminal 11 and N; replace mainboard, if required • Clean steam cylinder, cylinder base, water sensor tubing and drainage system

These icons are flashing	Fault code	Fault message	Possible cause	Measure
 	123	<p>Steam_down_time (only HKDB) The heaters are supplied with current, but water level doesnot change.</p>	<ul style="list-style-type: none"> • Heater element is defective. • Phase failure (external circuit breaker has tripped or is defective) • Heater elements not supplied with voltage • Main contactor swiching not o.k. • Main contactor not driven by mainboard relay 	<ul style="list-style-type: none"> • Measure heater element resistance; replace heater element, if required. Nominal resistance values are: FLH03 - 2.25 kW / 230 V - 21.3 - 26.1 Ω FLH06 – 4.5 kW / 400 V – 32.3 - 39.5 Ω FLH09 – 6.75 kW / 400 V - 21.5 - 26.3 Ω FLH15 – 3.8 kW / 400 V – 38.2 - 46.8 Ω (3x) FLH25 – 6.3 kW / 400 V – 23.1 - 28.2 Ω (3x) FLH30 – 3.8k W / 400 V - 38.2-46.8 Ω (6x) FLH40 – 6.3 kW / 400 V – 23.1 - 28.2 Ω (3x) + 3.8 kW / 400 V – 38.2 - 46.8 Ω (3x) FLH50 – 6.3 kW / 400 V – 23.1 - 28.2 Ω (6x) • Replace external circuit breaker, eliminate cause for tripping • Check wiring and voltage supply • Check main contactor, replace if required. • Measure voltage on mainboard terminal 9 against N; replace mainboard, if required
	124	<p>Relay_main_contactor (only HKDB) The main contactor is not driven by the electronics on the mainboard, but a voltage is measured</p>	<ul style="list-style-type: none"> • Mainboard relay contacts stick 	<ul style="list-style-type: none"> • Replace mainboard

These icons are flashing	Fault code	Fault message	Possible cause	Measure
	240	Temp._sensor_miss No measurements available	<ul style="list-style-type: none"> • Sensor not connected or defective • Connecting line damaged • Input level is defective 	<ul style="list-style-type: none"> • Check sensor connection, replace sensor if required • Check connecting line • Replace mainboard
	241	Temp._sensor_broken No measurements or implausible measurements	<ul style="list-style-type: none"> • Sensor defective • Connecting line damaged • Input level is defective 	<ul style="list-style-type: none"> • Replace sensor • Check connecting line • Replace mainboard
	242	Temperature_max. The Temp._actual value has exceeded the set value by the "Δ temp._max." value specified	<ul style="list-style-type: none"> • Heat build-up in the cabin • Additional heat source(s) in the steam cabin • Power retention is set to high 	<ul style="list-style-type: none"> • Ensure continuous heat dissipation • Check heat sources • Check parameter settings
	243	Temp._sensor 2_miss No measurements available	<ul style="list-style-type: none"> • Sensor not connected or defective • Connecting line damaged • Input level is defective 	<ul style="list-style-type: none"> • Check sensor connection, replace sensor if required • Check connecting line • Replace relay board
	244	Temp._Sensor 2_broken No measurements or implausible measurements	<ul style="list-style-type: none"> • Sensor defective • Connecting line damaged • Input level is defective 	<ul style="list-style-type: none"> • Replace sensor • Check connecting line • Replace relay board
	245	Temp._deviation The two temperature sensors provide values whose deviation from each other is outside the tolerance	<ul style="list-style-type: none"> • One of the sensors is defective 	<ul style="list-style-type: none"> • Identify defective sensor and replace

7.2 Servicemessages and warnings

Service messages and warnings are shown on the main screen in place of the HygroMatic logo, when the cause has occurred. When tipping the display field, the unit info screen is shown with the messages in plain text.

Mainscreen presentation	Message	Possible cause	Countermeasure
	Steam_amount counter	The maintenance interval has expired.	Service or check steam humidifier. Reset the steam amount counter (also see chapter 6.8.4.1 „Monitoring and service messages“).
	Cycles_main_contactor „x“	The maximum number of operating cycles for the main contactor „x“ has been reached (the device can contain several main contactors. „x“ represents the designation number of the main contactor concerned.)	The main contactor should be changed. After replacement, the respective counter must be reset with the parameter „Main_contactor_Kx_Reset“ (x=number of main contactor, 1...5) (also see chapter 6.8.4.1 „Monitoring and service messages“).
	Warning_cyl_full (only ELDB)	Electrode wear is very advanced.	Replace Electrodes.
	Warning_pump	A performance capability decrease is detected in the area of the blow-down pump and its hosing.	Check area and clean. If warning persists, replace blow-down pump.
	Warning_valve	A performance capability decrease is detected in the area of the solenoid valve, cylinder base and its hosing.	Check area and clean. If warning persists check cylinder base for lime deposit.

The sensitivity threshold of the last three warning messages is set to the highest level ex factory. Should the on-site conditions (e.g. the water conductivity) lead to an unwanted frequent occurrence of the messages, the sensitivity can be reduced in the „Service“ submenu (s. section 6.8.4).

7.3 Functional fault chart

Possible condition	Possible cause for fault situation	Countermeasure
Water collects on bottom plate	<ul style="list-style-type: none"> • Cylinder assembled incorrectly after maintenance: <ul style="list-style-type: none"> - O-ring damaged, not replaced or not inserted - Flange (tongue / groove) damaged. - Flange not closed properly - Scale deposits in flange • Cylinder improperly inserted in cylinder base • Water cannot drain freely when pumped from cylinder 	<ul style="list-style-type: none"> • Clean cylinder and assemble / install properly • Using moistened new O-ring, insert steam cylinder properly into cylinder base • Ensure free drainage
Water leaks from steam cylinder upper part	<ul style="list-style-type: none"> • Hose clamps on steam and/or condensate hose not tightened • Steam hose adapter not properly fit or O-ring not replaced 	<ul style="list-style-type: none"> • Tighten clamps • Replace O-ring (if required) and ensure proper adapter installation
No steam production despite the steam generator being switched on and an illuminated display	<ul style="list-style-type: none"> • The interlock (safety) system is open • The temperature set value has been reached. The control receives no demand for steam production. • Little air exchange; steam bath temperature remains above the programmed set value for a long time 	<ul style="list-style-type: none"> • Close Interlock (safety) system • Check set value settings, check the plausibility of the temp._actual value • Provide for sufficient air exchange by adjusting fan performance
No steam production. Voltage across electrodes exist, but no water is fed into the cylinder (only ELDB)	<ul style="list-style-type: none"> • Water supply not opened or solenoid valve electrically not driven 	<ul style="list-style-type: none"> • Open water supply (s. also Filling fault messages 030 and 032)
The set point temperature is not reached	<ul style="list-style-type: none"> • Output limitation parameter setting impedes full power output • Nominal power output insufficient • Lengthy steam hose layout crossing cold and drafty rooms may lead to increased condensate formation • Unit is operated in "Cylinder full" (for ELDB only). • Incorrect performance design 	<ul style="list-style-type: none"> • Check „Steam_output_max.“ parameter setting („Control“ submenu, line 2) • Check unit technical data, airflow and secondary airflow • Change unit installation location allowing for shorter steam hose. Insulate steam hose • see fault code 090 (Cylinder_full) • Check performance data, cabin size and thermal insulation

Possible condition	Possible cause for fault situation	Countermeasure
The set point temperature is not reached (ctd.)	<ul style="list-style-type: none"> • Failure of a phase (external fuse) 	<ul style="list-style-type: none"> • Check fuse and switch on or replace if required
No visible steam in the cabin	<ul style="list-style-type: none"> • Unsuitable comprehensive insulation of steam bath • Insufficient ventilation in the steam bath • Additional heat supply (e.g. due to heated benches) 	<ul style="list-style-type: none"> • Ensure heat dissipation can take place • Install exhaust fan or increase exhaust performance • Reduce additional heat supply
Temperature too high	<ul style="list-style-type: none"> • Temperature sensor is not calibrated correctly 	<ul style="list-style-type: none"> • Correct using the "Correction_°C-signal" parameter
No essence or too little essence supply in steam bath	<ul style="list-style-type: none"> • No essence in the respective container • Essence supply not enabled or not functional • Essence filling time too low • Essence pause time too long • Fuse or relay for essence in control defective (for 24 V applications) • Hose in peristaltic pump defective (essence runs back into essence container via return line) 	<ul style="list-style-type: none"> • Refill essence • Enable essence supply (check the voltage supply of the peristaltic pump) • Set longer filling time • Set shorter pause time • Check fuse and relay, replace if required • Replace hose in peristaltic pump
Excessive essence supply in steam bath	<ul style="list-style-type: none"> • Essence filling time too high • Essence pauses too short 	<ul style="list-style-type: none"> • Set shorter essence filling time • Set longer pause time
No steam production despite the steam humidifier being switched on. Display not illuminated	<ul style="list-style-type: none"> • Defective F1 and/or F2 fuses on main-board • External control voltage failure (ext. circuit breaker has tripped or is defective) • Circuit breaker in unit was triggered (EL-DB only) 	<ul style="list-style-type: none"> • Check micro-fuses and replace, if required • Replace breaker and investigate possible causes • Switch on breaker. If problem persists, check for reason
Blow-down pump works but no water is drained	<ul style="list-style-type: none"> • Steam cylinder and/or drainage system blocked 	<ul style="list-style-type: none"> • Clean cylinder base and/or drainage system, respectively

Possible condition	Possible cause for fault situation	Countermeasure
Cylinder is completely emptied after a blow-down, even though the pump has switched off.	<ul style="list-style-type: none"> • Vent pipe is blocked 	<ul style="list-style-type: none"> • Clean venting bore; replace vent pipe, if required
No steam exit	<ul style="list-style-type: none"> • Steam pipe improperly laid (water bag) or blockage 	<ul style="list-style-type: none"> • Rerun steam hose according to guide lines • Remove blockage
Water exits periodically from drain hose without pump switched on	<ul style="list-style-type: none"> • Excess pressure in duct system (max. overpressure is 1200 Pa) 	<ul style="list-style-type: none"> • Lengthen drain hose system; consult your expert dealer if problem persists
Uneven electrode wear (ELDB only)	<ul style="list-style-type: none"> • One or more electrodes not supplied with power • Circuit breaker tripped • Main contactor contact does not switch • Phase loading not symmetric • Electrode immersion depth differs. Unit not mounted plumb 	<ul style="list-style-type: none"> • Check power supply and electrode wiring • Check circuit breaker, replace if required • Check main contactor, replace if required • Ensure power supply phase balance by measurement • Check installation and correct positioning, if required

Possible condition	Possible cause for fault situation	Countermeasure
Flashover/sparks in cylinder(only ELDB)	<ul style="list-style-type: none"> • Very high water conductivity resulting in massive electrode burn-off as indicated by brown-black deposits • Blow-down pump not working properly or defective 	<ul style="list-style-type: none"> • Deactivate unit immediately to prevent material damage <p>Perform maintenance:</p> <ul style="list-style-type: none"> - replace electrodes with high conductivity type - clean steam cylinder - check water quality and conductivity (also s. „Intended use“ section) - optimise blow-down parameters <p>Consult your expert dealer, if required</p> <ul style="list-style-type: none"> • Check blow-down pump functioning and replace pump, if required. See also fault messages 061 to 067 related to blow-down

8. Wiring diagrams

8.1 FLE - Option 230V

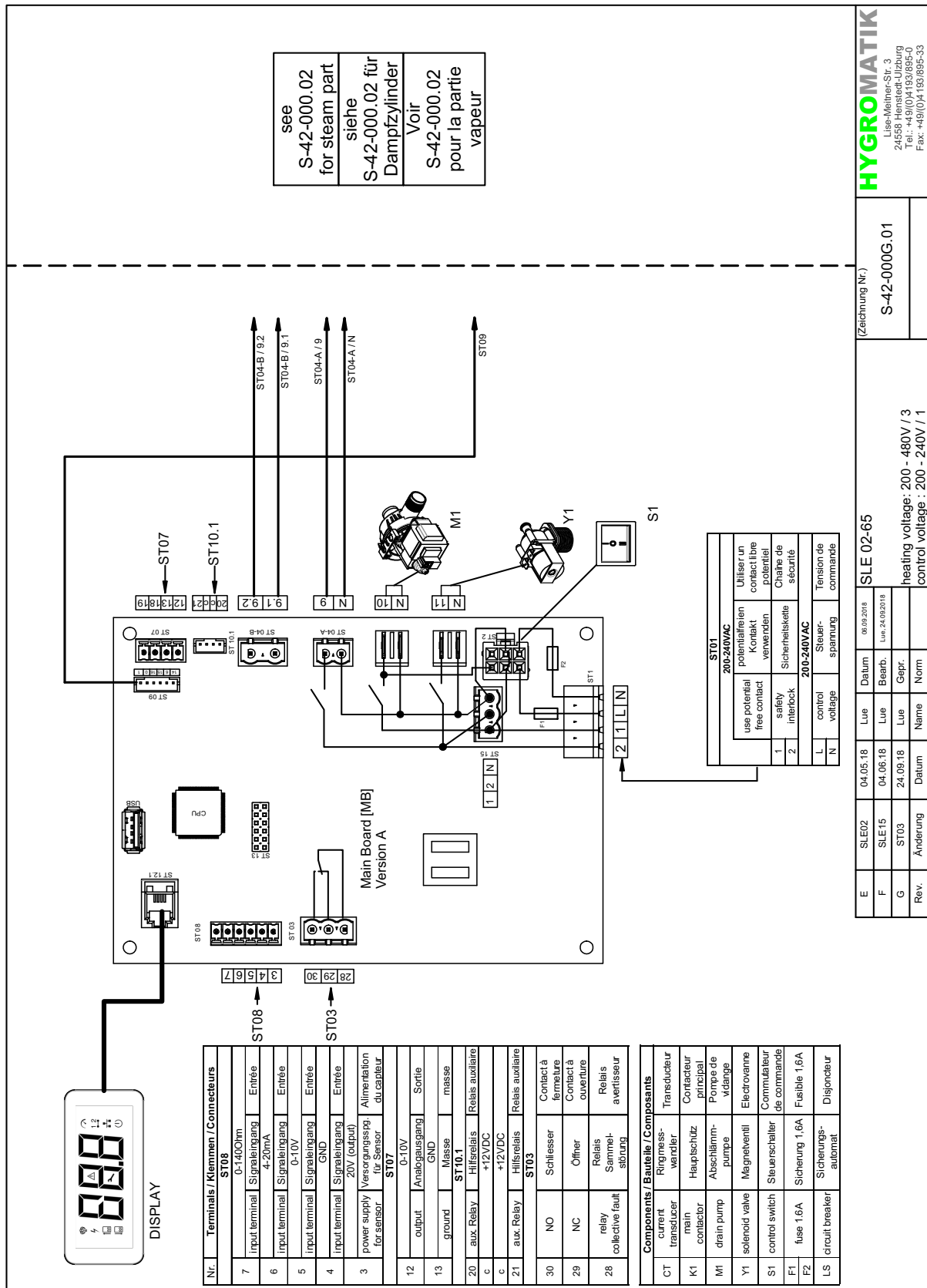

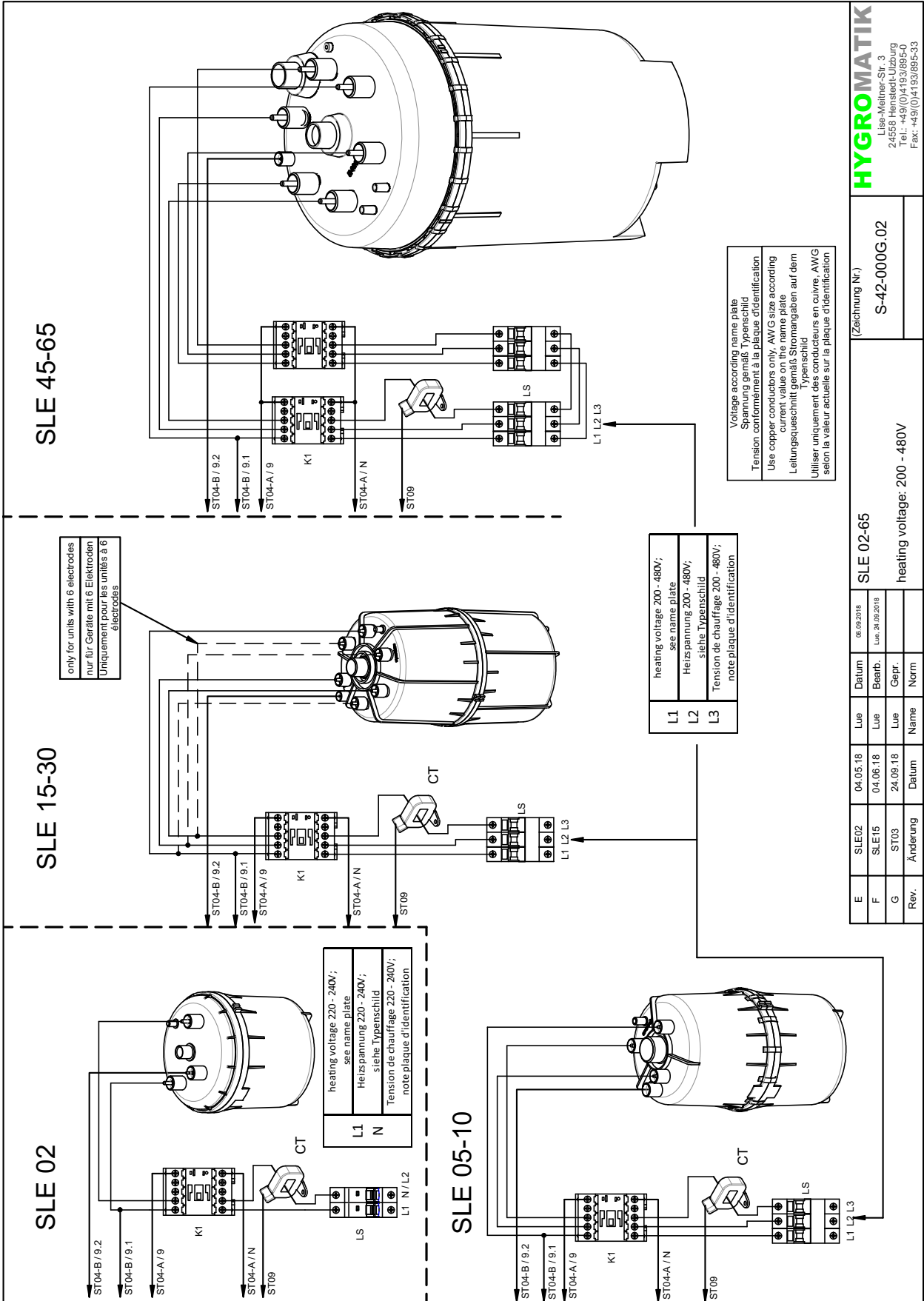

HYGROMATIK
Lise-Meiner-Str. 3
24558 Henstedt-Ubburg
Tel.: +49 (0)4193/895-0
Fax: +49 (0)4193/895-33

(Zeichnung Nr.)
S-42-000G.02

SLE 02-65
heating voltage: 200 - 480V

E	SLE02	04.05.18	Lue	Datum	08.09.2018
F <td>SLE15 <td>04.06.18 <th>Lue</th> <td>Bearb.</td> <td>Lue 20.09.2018</td> </td></td>	SLE15 <td>04.06.18 <th>Lue</th> <td>Bearb.</td> <td>Lue 20.09.2018</td> </td>	04.06.18 <th>Lue</th> <td>Bearb.</td> <td>Lue 20.09.2018</td>	Lue	Bearb.	Lue 20.09.2018
G <td>ST03 <td>24.09.18 <th>Lue</th> <td>Gepr.</td> <td></td> </td></td>	ST03 <td>24.09.18 <th>Lue</th> <td>Gepr.</td> <td></td> </td>	24.09.18 <th>Lue</th> <td>Gepr.</td> <td></td>	Lue	Gepr.	
Rev.	Änderung	Datum	Name	Norm	

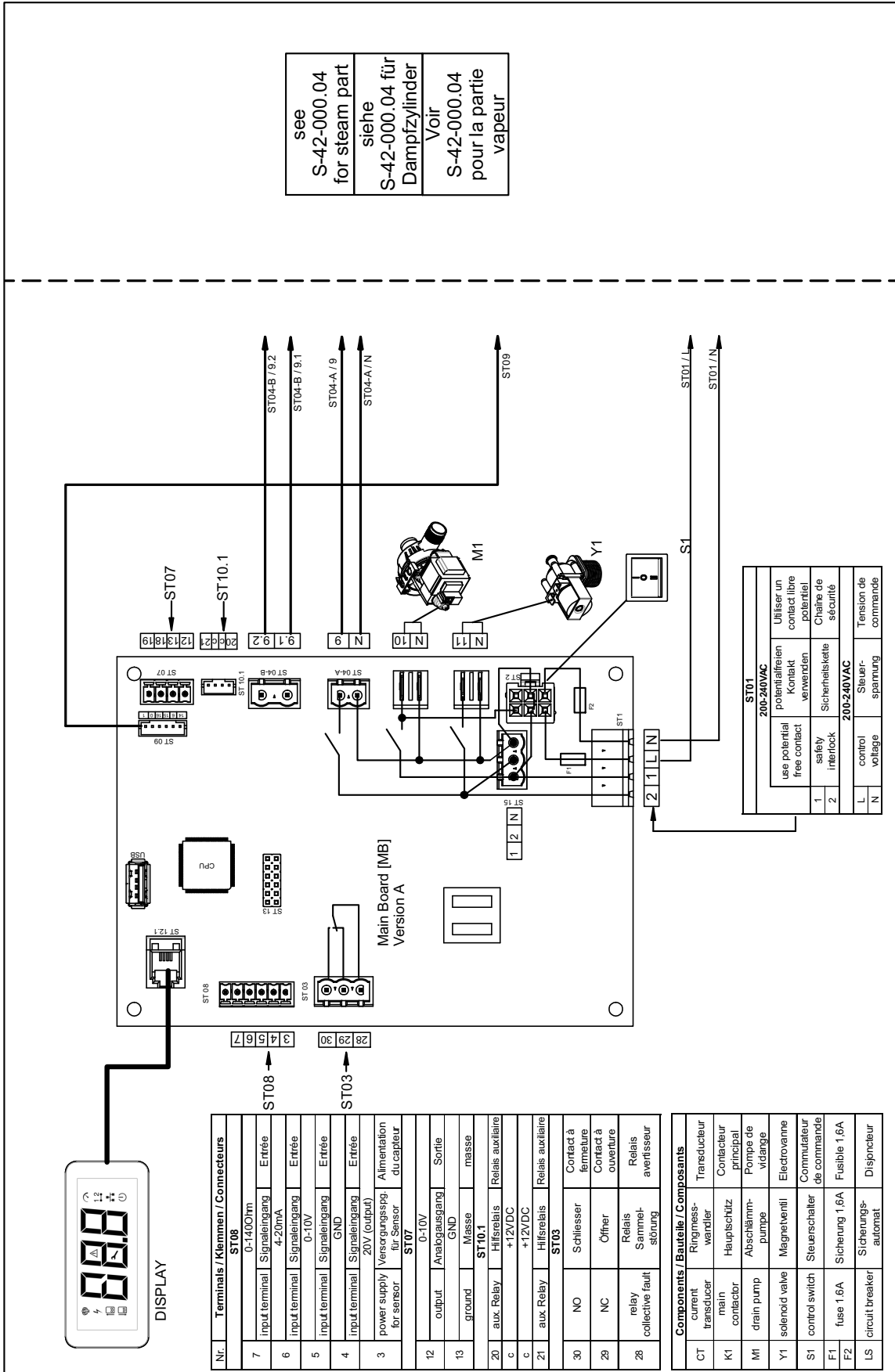

see
S-42-000.04
for steam part

siehe
S-42-000.04 für
Dampfzylinder

Voir
S-42-000.04
pour la partie
vapeur

Nr.	Terminals / Klemmen / Connecteurs
ST08	
7	Input terminal Signaleingang 0-140Ohm Erträge
6	Input terminal Signaleingang 4-20mA Erträge
5	Input terminal Signaleingang 0-10V Erträge
4	Input terminal Signaleingang GND Erträge
3	Input terminal Signaleingang 20V (output) Erträge
2	power supply Versorgungsppg Alimentation für Sensor du capteur
ST07	
12	output Analogausgang Sortie
13	ground Masse masse
ST10.1	
20	aux. Relay Hilfsrelais Relais auxiliaire
c	ground Masse masse
21	aux. Relay Hilfsrelais Relais auxiliaire
ST03	
30	NO Schliesser Contact à fermeture
29	NC Öffner Contact à ouverture
28	Relais Relais Relais
27	Sammelstörung Collectif avertisseur

Components / Bauteile / Composants	
CT	current transducer Ringmesswandler Transducteur
K1	main contactor Hauptschütz Contacteur principal
M1	drain pump Abschlamm-pumpe Pompe de vidange
Y1	solenoid valve Magnetventil Electrovanne
S1	control switch Steuerschalter Commutateur de commande
F1	fuse 1.6A Sicherung 1,6A Fusible 1,6A
LS	circuit breaker Sicherungsautomat Disjoncteur

HYGROMATIK
Lise-Meiners Str. 3
24559 Hohenlock-Urburg
Tel.: +49(0)4193/895-0
Fax: +49(0)4193/895-33

(Zeichnung Nr.)
S-42-000G.03

Rev.	Änderung	Datum	Name	Norm
E	SLE02	04.05.18	Lue	
F	SLE15	04.06.18	Lue	
G	ST03	24.09.18	Lue	

heating voltage: 200 - 480V / 3 / N
internal control voltage : 200 - 240V / 1 / N

Rev.	Änderung	Datum	Name	Norm
E	SLE02	04.05.18	Lue	
F	SLE15	04.06.18	Lue	
G	ST03	24.09.18	Lue	

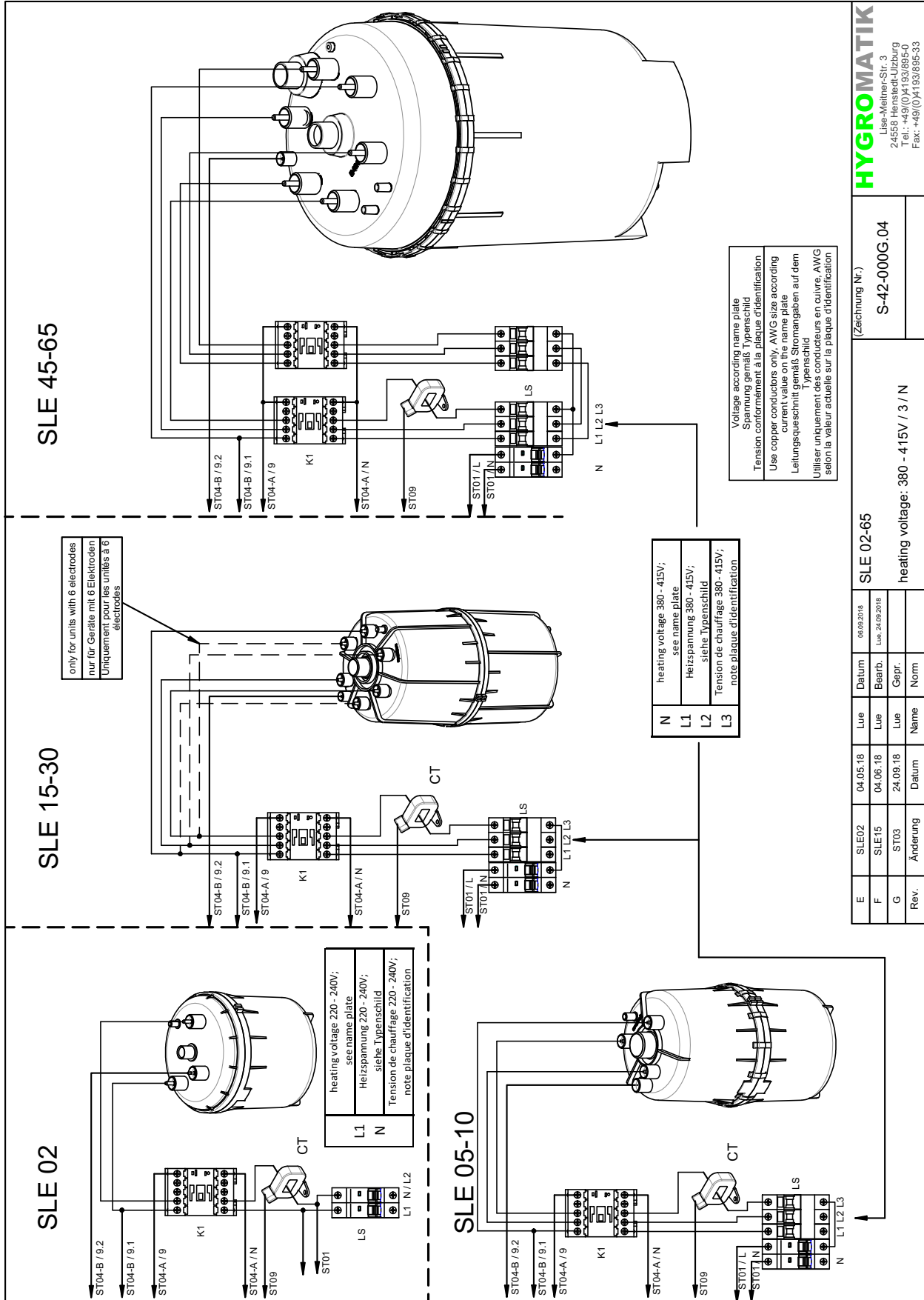

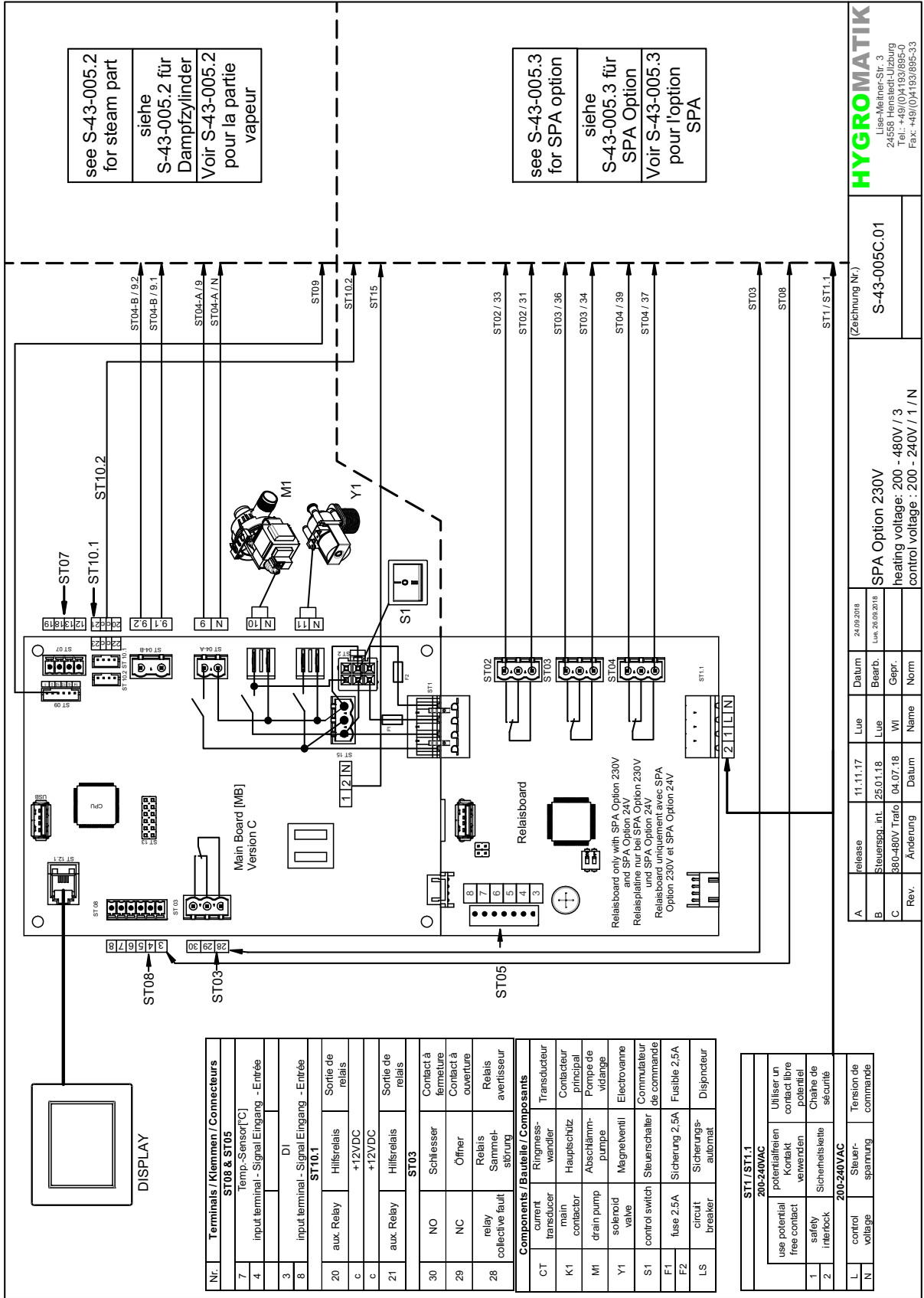

see S-43-005.2
for steam part
siehe
S-43-005.2 für
Dampfzylinder
Voir S-43-005.2
pour la partie
vapeur

see S-43-005.3
for SPA option
siehe
S-43-005.3 für
SPA Option
Voir S-43-005.3
pour l'option
SPA

Nr.	Terminals / Klemmen / Connecteurs	
ST08 & ST05		
7	Temp.-Sensor [°C]	
4	input terminal - Signal Eingang - Entrée	
3	DI	
8	input terminal - Signal Eingang - Entrée	
ST10.1		
20	aux. Relay Hilfsrelais	
6	Sortie de relais	
6	+12VDC	
ST03		
21	aux. Relay Hilfsrelais	
Sortie de relais		
ST03		
30	NO Schliesser	
	Contact à fermeture	
29	NC Öffner	
	Contact à ouverture	
28	Relais Sammel-avertisseur	
	collective fault	
Components / Bauteile / Composants		
CT	current transducer	Ringmesswandler
K1	main contactor	Hauptschütz
M1	drain pump	Abschlämp-pumpe
Y1	solenoid valve	Magnetventil
S1	control switch	Steuerschalter
F1	fuse 2.5A	Sicherung 2,5A
F2	fuse 2.5A	Fusible 2,5A
LS	circuit breaker	Sicherungsautomat

ST1 / ST1.1		
200-240VAC		
use potential free contact	Utiliser un contact libre potentiel	
1	safety interlock	Sicherheitsstelle
200-240VAC		
L	control voltage	Steuerspannung
N		Tension de commande

HYGROMATIK
Lise-Meineer-Str. 3
24559 Henseloh-Utzburg
Tel.: +49 (0)4193/895-0
Fax: +49 (0)4193/895-33

(Zeichnung Nr.)
S-43-005C.01

SPA Option 230V
heating voltage: 200 - 480V / 3
control voltage: 200 - 240V / 1 / N

Rev.	Änderung	Datum	Name	Norm
A	release	11.11.17	Lue	
B	Steuerung, int.	25.01.18	Lue	
C	380-480V Trafu	04.07.18	Wl	

A	release	Datum	Name	Norm
	release	24.09.2016	Lue	
	Steuerung, int.	25.01.18	Lue	
	380-480V Trafu	04.07.18	Wl	

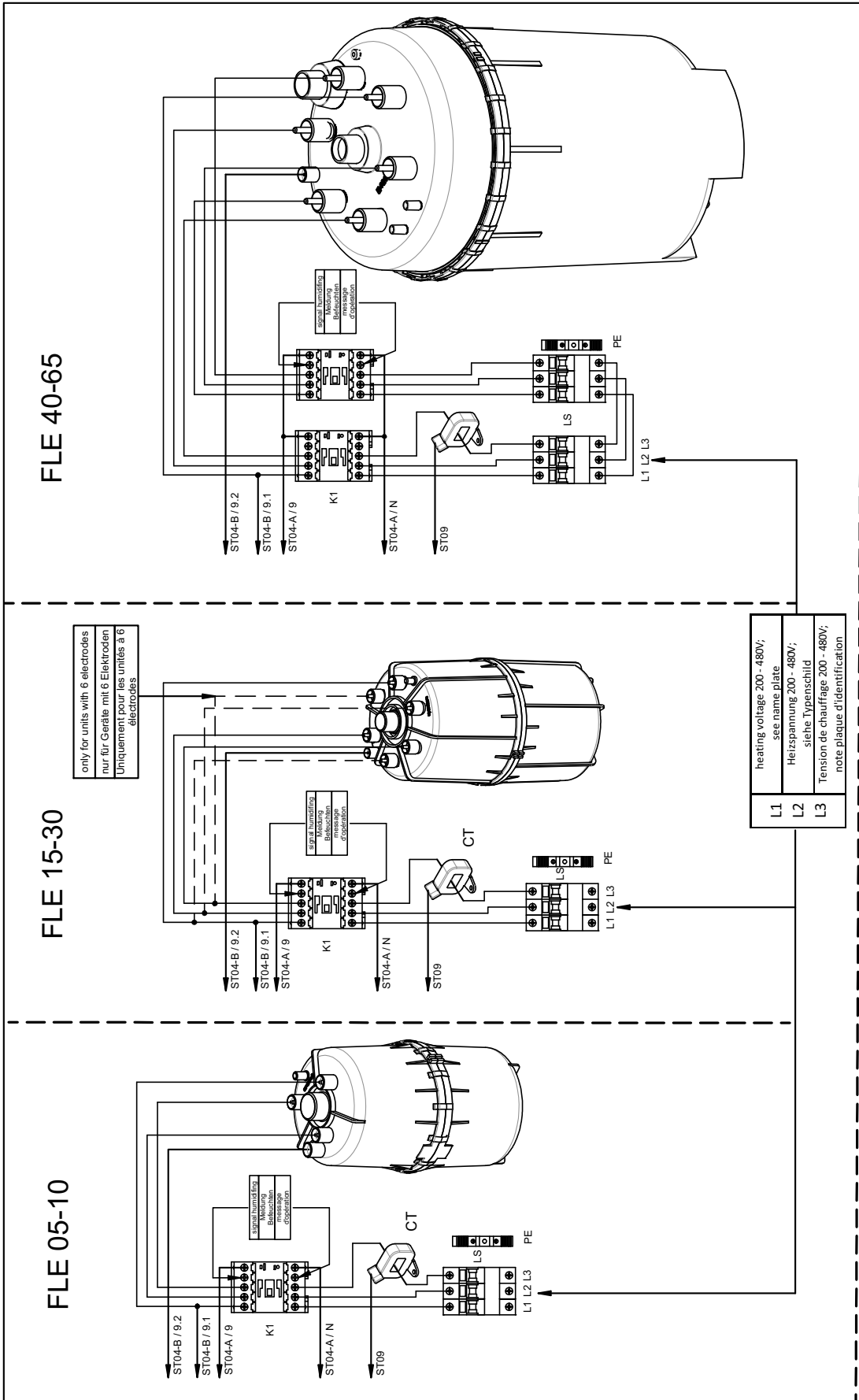

FLE 40-65

FLE 15-30

FLE 05-10

only for units with 6 electrodes
 nur für Geräte mit 6 Elektroden
 Uniquement pour les unités à 6 électrodes

L1	heating voltage 200 - 480V; see name plate
L2	Heizspannung 200 - 480V; siehe Typenschild
L3	Tension de chauffage 200 - 480V; note plaque d'identification

Voltage according name plate
 Spannung gemäß Typenschild
 Tension conformément à la plaque d'identification

Use copper conductors only. AWG size according current value on the name plate
 Leitungsschnitt Kupferkabel gemäß Stromangaben auf dem Typenschild
 Utiliser uniquement des conducteurs en cuivre, AWG selon la valeur actuelle sur la plaque d'identification

<p>HYGROMATIK Lise-Meiner-Str. 3 24558 Henstedt-Ujzburg Tel.: +49(0)4193/895-0 Fax: +49(0)4193/895-33</p>		<p>(Zeichnung Nr.) S-43-005C.02</p>			
		<p>FLE 05-65 - SPA heating voltage: 200 - 480V / 3</p>			
A	release	11.11.17	Lue	24.09.2018	Datum
B	Steuerung.int.	25.01.18	Lue	26.09.2018	Bearb.
C	380-480V	04.07.18	WI		Gepr.
Rev.	Änderung	Datum	Name	Norm	

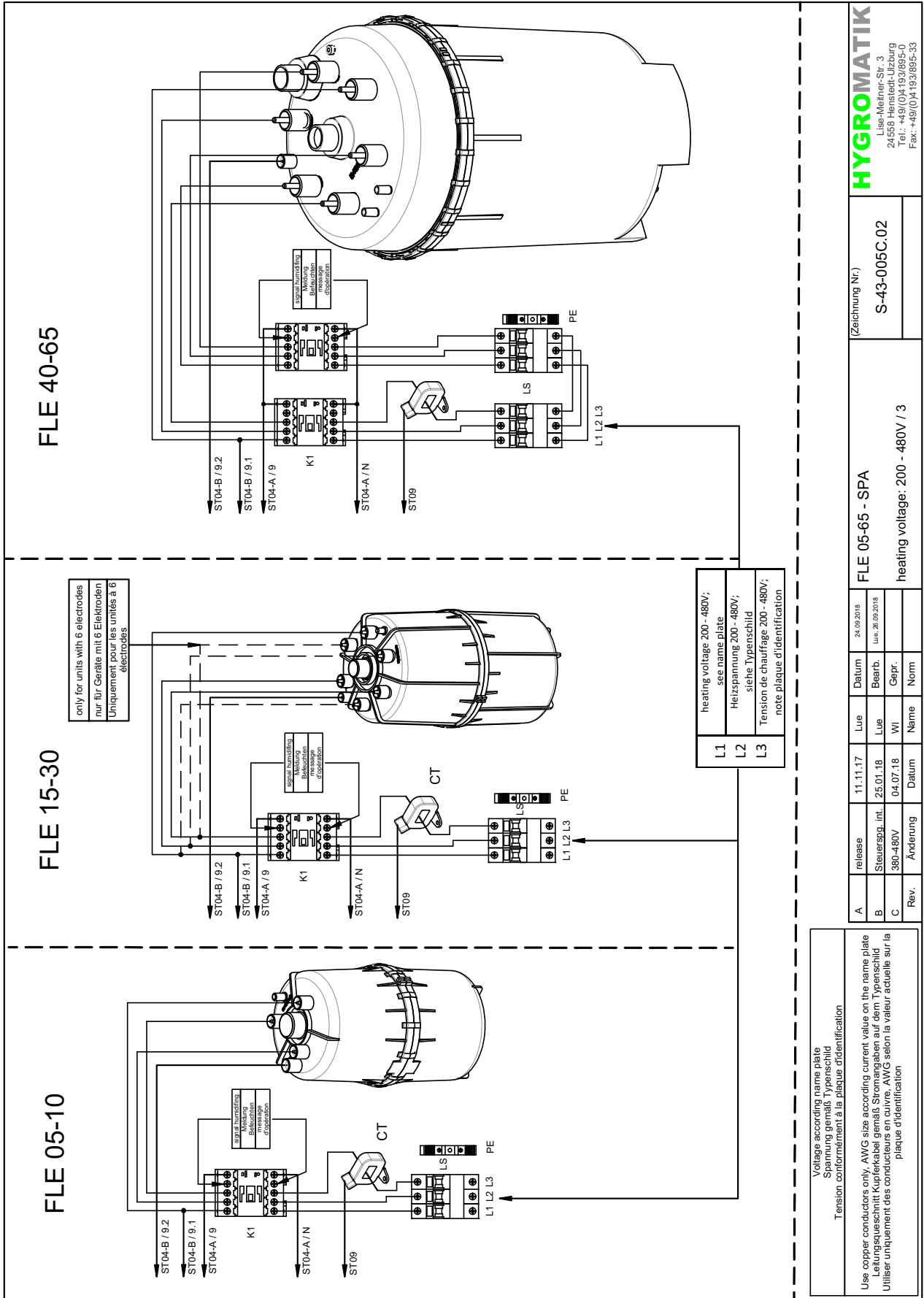

HYGROMATIK
Lies-Meines-Str. 3
24559 Hildesheim, Jülichberg
Tel.: +49 (0)4193/895-0
Fax: +49 (0)4193/895-33

(Zeichnung Nr.)
S-43-005C.02

FLE 05-65 - SPA
heating voltage: 200 - 480V / 3

Rev.	Änderung	Datum	Name	Norm
A	release	11.11.17	Lue	
B	Steuerschl. int.	25.01.18	Lue	
C	390-480V	04.07.18	Wl	Gepr.

Voltage according name plate
Spannung gemäß Typenschild
Tension conformément à la plaque d'identification

Use copper conductors only, AWG size according current value on the name plate
Leitungsquerschnitt Kupferkabel gemäß Stromangaben auf dem Typenschild
Utiliser uniquement des conducteurs en cuivre, AWG selon la valeur actuelle sur la plaque d'identification

SPA Option 24V

with relay board
mit Relais Platine
avec platine relais

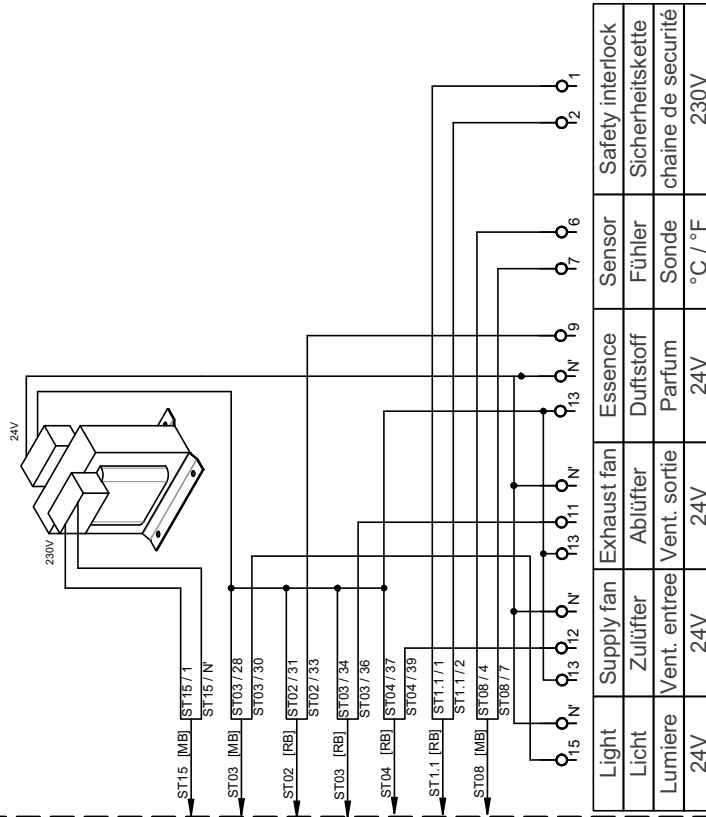

SPA Lite Option 24V

without relay board
ohne Relais Platine
sans platine relais

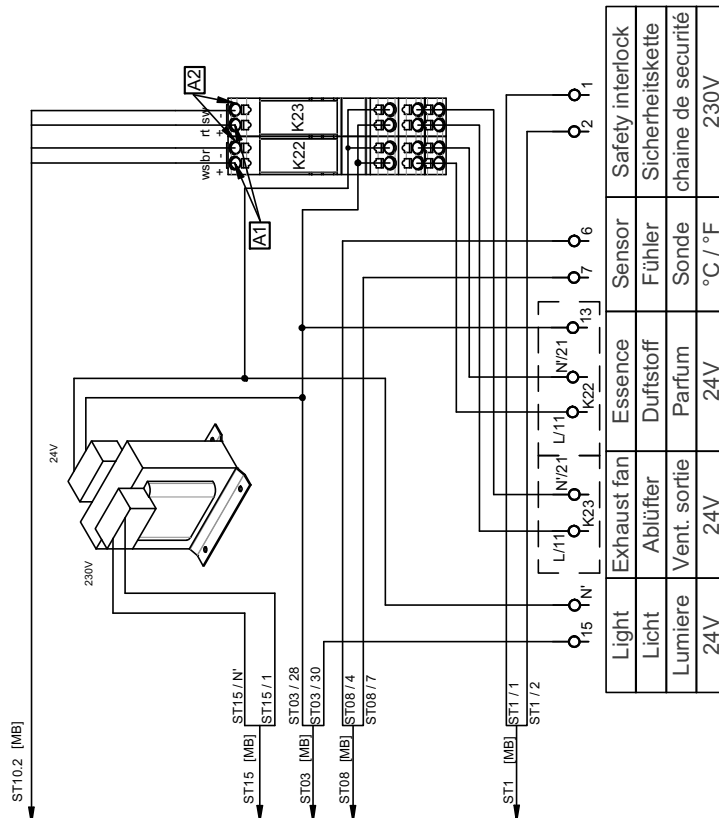

HYGROMATIK
Lise-Meiher-Str. 3
24558 Hensched-Ulzburg
Tel.: +49/(0)4193/895-0
Fax: +49/(0)4193/895-33

(Zeichnung Nr.)
S-43-005C.06

SPA Option
control voltage: 24VAC 130VA

A	release	11.11.17	Lue	24.09.2018	SPA Option
B	Steuerspa. int.	25.01.18	Lue	Lue, 26.09.2018	
C	13 - 9 Opt.24V	12.06.18	WI	Gepr.	
Rev.	Änderung	Datum	Name	Norm	

8.3 FLH - Option 230V

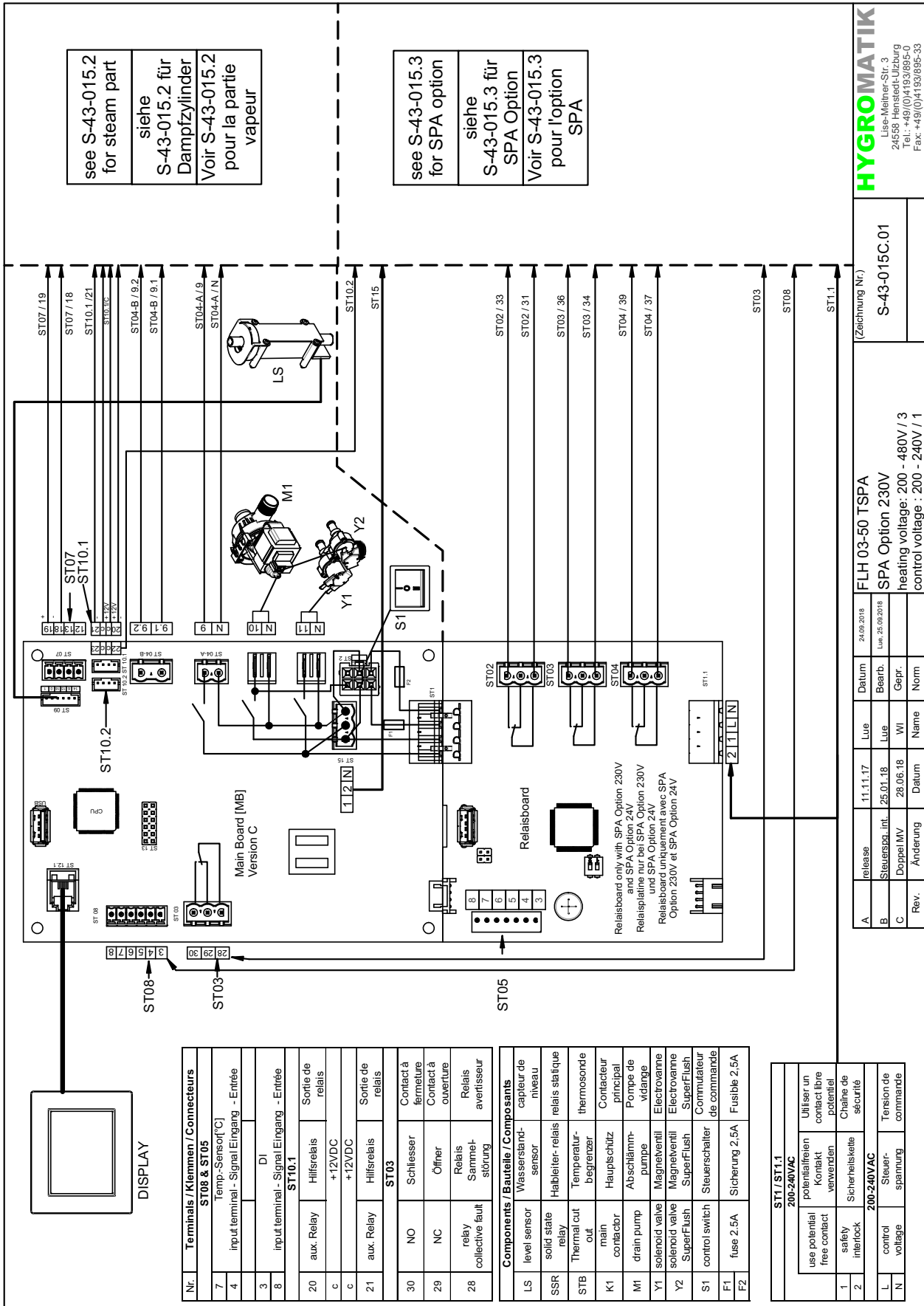

see S-43-015.2
for steam part

siehe
S-43-015.2 für
Dampfzylinder

Voir S-43-015.2
pour la partie
vapeur

see S-43-015.3
for SPA option

siehe
S-43-015.3 für
SPA Option

Voir S-43-015.3
pour l'option
SPA

Nr.	Terminals / Klemmen / Connecteurs
ST08 & ST05	
7	Temp.-Sensor[C]
4	input terminal - Signal Eingang - Entrée
3	DI
8	input terminal - Signal Eingang - Entrée
ST10.1	
20	aux. Relay Hilfsrelais
c	+12VDC
c	+12VDC
21	aux. Relay Hilfsrelais
ST03	
30	NO Schliesser
29	NC Öffner
28	relay collective fault Relais Sammelstörung

Components / Bauteile / Composants	
LS	level sensor Wasserstandssensor
SSR	solid state relay Halbleiterrelais
STB	Thermal cut out Temperaturbegrenzer
K1	main contactor Hauptschutz
M1	drain pump Abschlämpumpe
Y1	solenoid valve Magnetenventil
Y2	solenoid valve Magnetenventil
S1	control switch Steuerschalter
F1	fuse 2.5A Sicherung 2.5A
F2	fuse 2.5A Fusible 2.5A

ST1 / ST1.1	
200-240VAC	
use potential free contact	Utiliser un contact libre potentiel
1	safety interlock Sicherheitskette
2	control voltage
L	Steuer-spannung
N	Tension de commande

ST1 / ST1.1	
200-240VAC	
use potential free contact	Utiliser un contact libre potentiel
1	safety interlock Sicherheitskette
2	control voltage
L	Steuer-spannung
N	Tension de commande

HYGROMATIK
Lise-Meiner-Str. 3
24538 Hainstedt-Culzburg
Tel.: +49(0)4193895-33
Fax: +49(0)4193895-33

(Zeichnung Nr.)
S-43-015C.01

FLH 03-50 TSPA
SPA Option 230V
heating voltage: 200 - 480V / 3
control voltage: 200 - 240V / 1

Rev.	Änderung	Datum	Name	Gepr.	Norm
A	release	11.11.17	Lue		
B	Steuersg. int.	25.01.18	Lue		
C	Doppel IMV	28.06.18	Wl		

A	release	11.11.17	Lue	Datum	24.06.2018
B	Steuersg. int.	25.01.18	Lue	Datum <td>Lue</td>	Lue
C	Doppel IMV	28.06.18	Wl	Gepr.	Lue

FLH 03-09

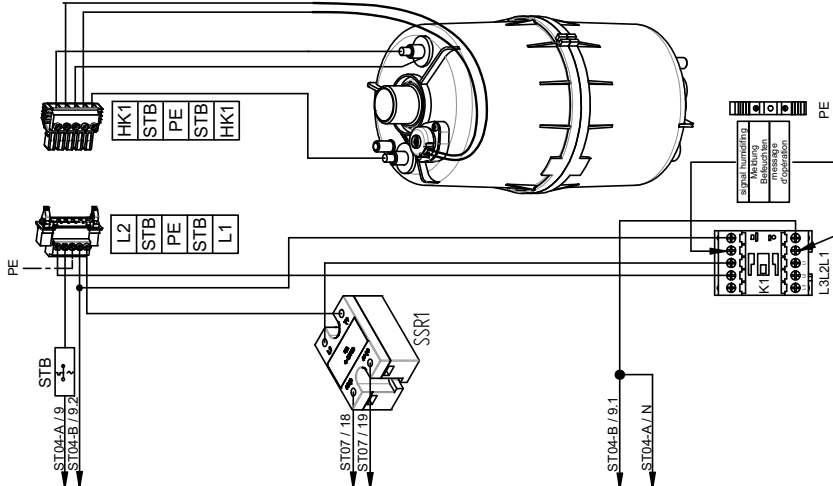

HK1 = FLH03 2,25KW heating element / Heizkörper / Élément chauffant
 HK1 = FLH06 4,5KW heating element / Heizkörper / Élément chauffant
 HK1 = FLH09 6,75KW heating element / Heizkörper / Élément chauffant
 heating voltage 380 - 415V;
 see name plate
 Heizspannung 380 - 415V;
 siehe Typenschild
 Tension de chauffage 380 - 415V;
 note plaque d'identification

FLH 15-25

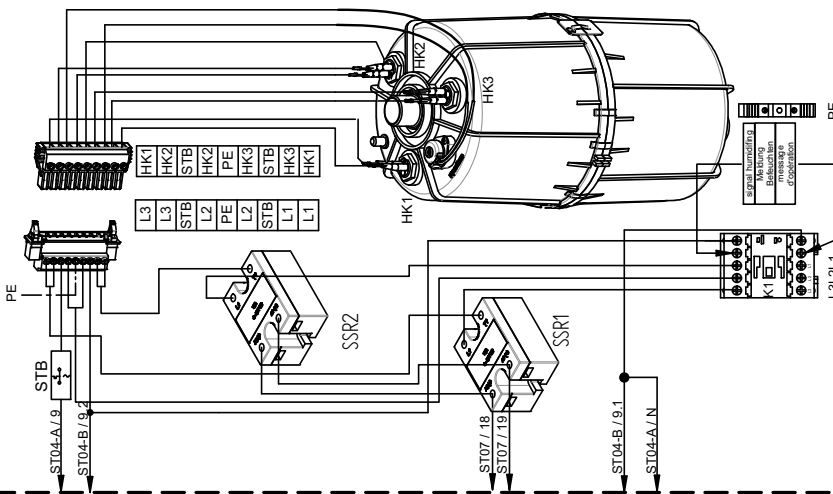

HK1-HK3 = FLH15 3,8KW heating element / Heizkörper / Élément chauffant
 HK1-HK3 = FLH25 6,3KW heating element / Heizkörper / Élément chauffant

FLH 30-50

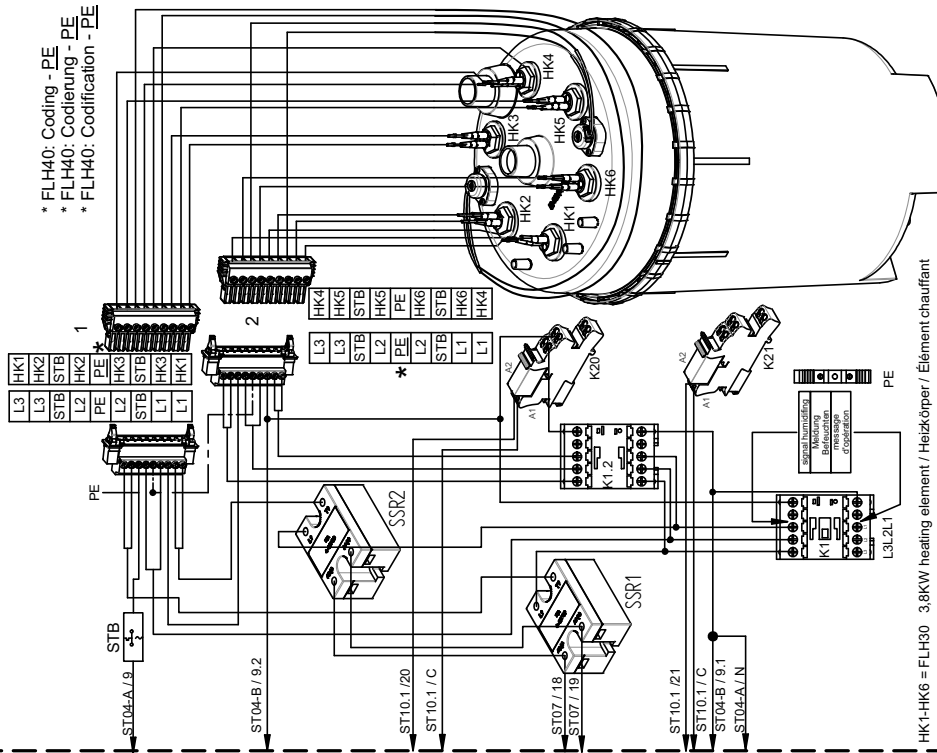

HK1-HK6 = FLH30 3,8KW heating element / Heizkörper / Élément chauffant
 HK4-HK6 = FLH40 3,8KW heating element / Heizkörper / Élément chauffant
 HK1-HK3 = FLH40 6,3KW heating element / Heizkörper / Élément chauffant
 HK1-HK6 = FLH50 6,3KW heating element / Heizkörper / Élément chauffant

K21 frei einstellbar - StandardEinstellung = Sammelstörung / K21 free adjustable - standard setting = collective fault /
 K21 réglable librement - Réglez standard Défaut collectif

HYGROMATIK
 Lise-Meiner-Str. 3
 24558 Henstedt-Ujzburg
 Tel.: +49(0)4193/895-0
 Fax: +49(0)4193/895-33

(Zeichnung Nr.)
S-43-015C.02

release	11.11.17	Lue	24.03.2018	Datum
Steuersop.int.	25.01.18	Lue	25.09.2018	Bearb.
HK Nr./K	07.06.18	WI		Gepr.
Änderung	Datum	Name		Norm

N	see name plate
L1	Heizspannung 380 - 415V;
L2	siehe Typenschild
L3	Tension de chauffage 380 - 415V; note plaque d'identification

FLH 03-50
 heating voltage: 200 - 480V / 3

SPA Option 230V

with relay board
mit Relais Platine
avec platine relais

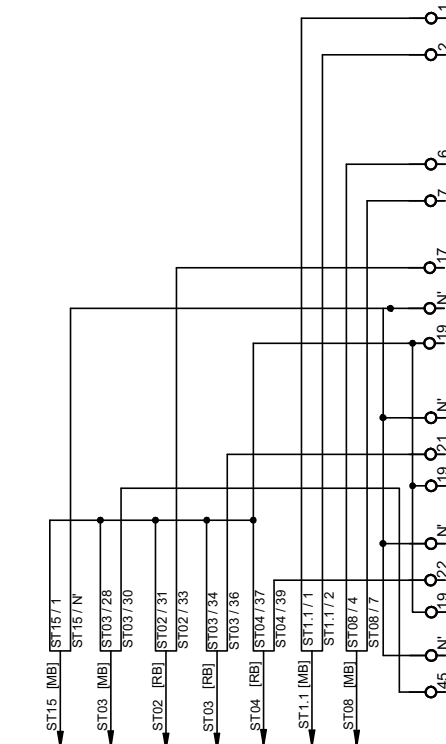

Light	Supply fan	Exhaust fan	Essence	Sensor	Safety interlock
Licht	Zuluflüfer	Ablüfter	Duftstoff	Fühler	Sicherheitskette
Lumiere	Vent. entree	Vent. sortie	Parfum	Sonde	chaîne de sécurité
230V	230V	230V	230V	°C / °F	230V

SPA Lite Option 230V

without relay board
ohne Relais Platine
sans platine relais

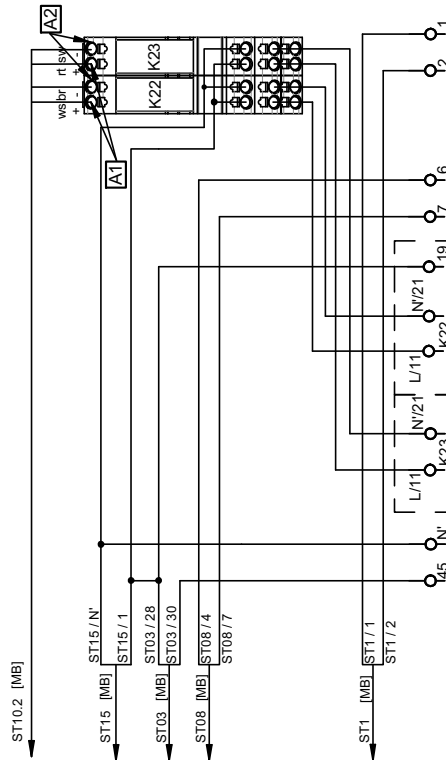

Light	Exhaust fan	Essence	Sensor	Safety interlock
Licht	Ablüfter	Duftstoff	Fühler	Sicherheitskette
Lumiere	Vent. sortie	Parfum	Sonde	chaîne de sécurité
230V	230V	230V	°C / °F	230V

HYGROMATIK Lise-Meiner-Str. 3 24558 Henstedt-Ujzburg Tel.: +49(0)4193/895-0 Fax: +49(0)4193/895-33				
(Zeichnung Nr.)	S-43-015B.03			
SPA Option	control voltage: 220-240V/1/N			
A release	21.06.18	WI	Datum	24.09.2018
B Terminal 19	24.09.18	Lue	Bearb.	Lue, 25.09.2018
Rev.	Änderung	Datum	Name	Gepr.
			Norm	

8.4 FLH - Option 24V

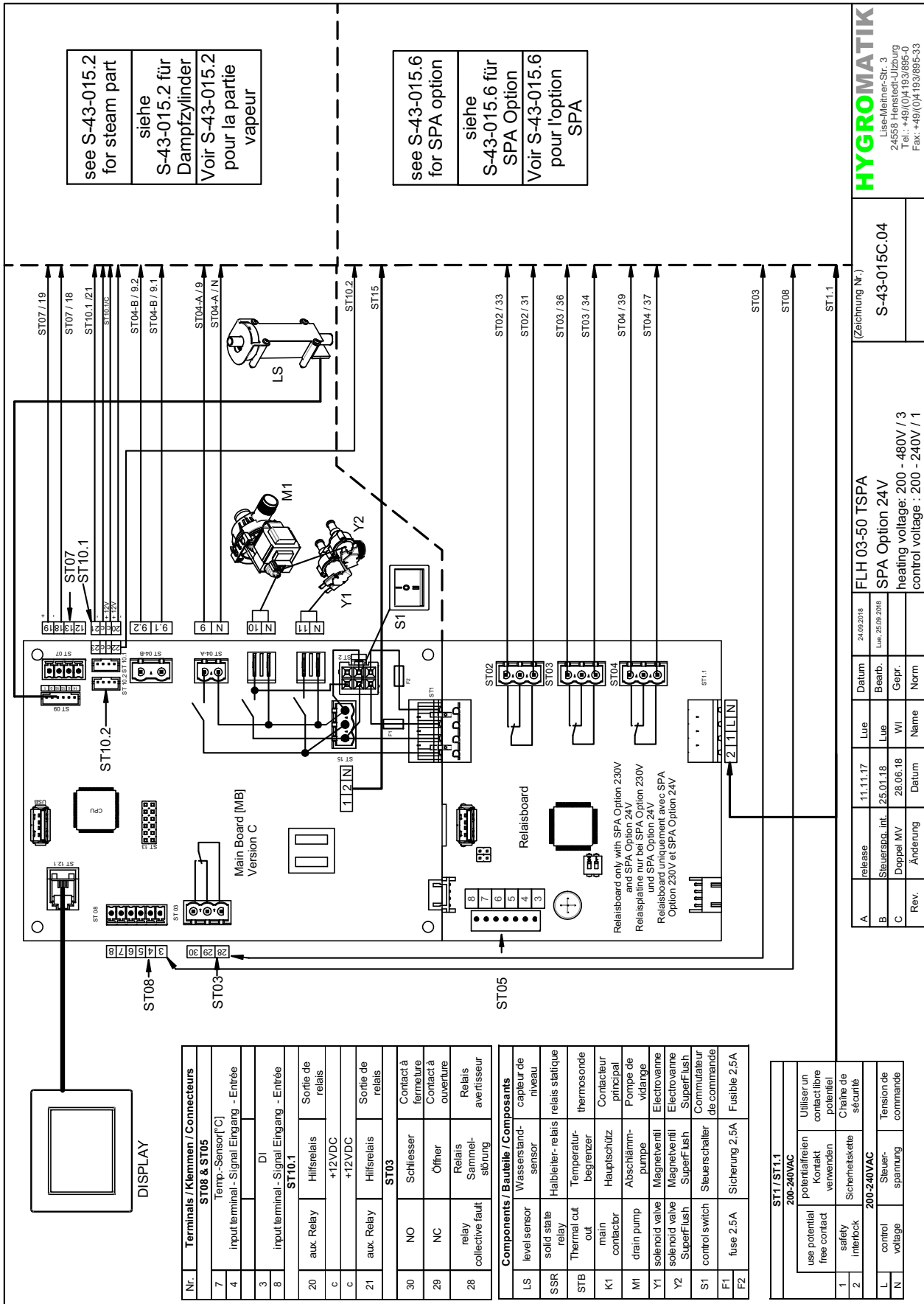

HYGROMATIK
 Lise-Melner-Str. 3
 24558 Henstedt-Utzburg
 Tel.: +49(0)4193/895-0
 Fax.: +49(0)4193/895-33

(Zeichnung Nr.)
S-43-015C.04

FLH 03-50 TSPA
SPA Option 24V
 heating voltage: 200 - 480V / 3
 control voltage: 200 - 240V / 1

Rev.	Änderung	Datum	Name	Norm
A	release	11.11.17	Lue	
B	Steuerschg. int.	25.01.18	Lue	
C	Doppel MV	28.06.18	Wi	Gepr.

A	release	11.11.17	Lue	Datum	Name	Norm
B	Steuerschg. int.	25.01.18	Lue			
C	Doppel MV	28.06.18	Wi	Gepr.		

FLH 03-09

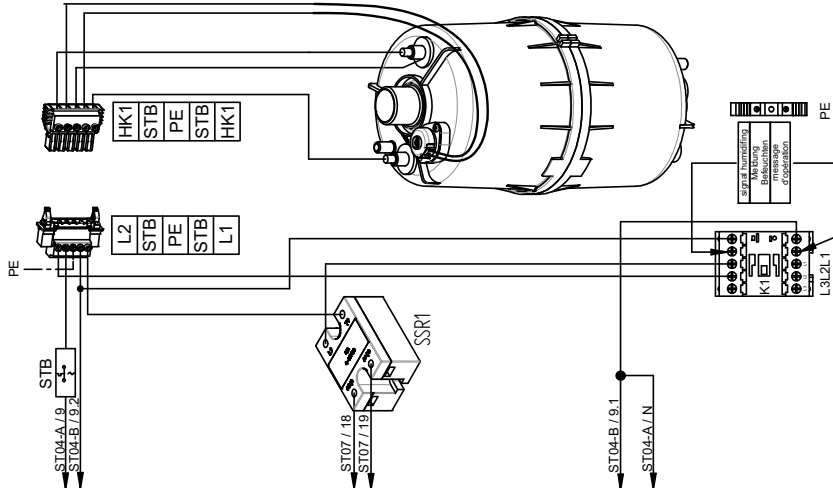

FLH 15-25

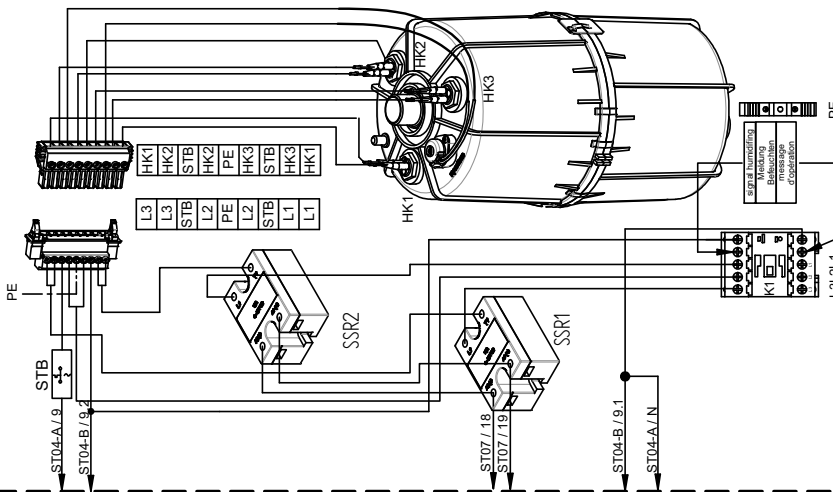

FLH 30-50

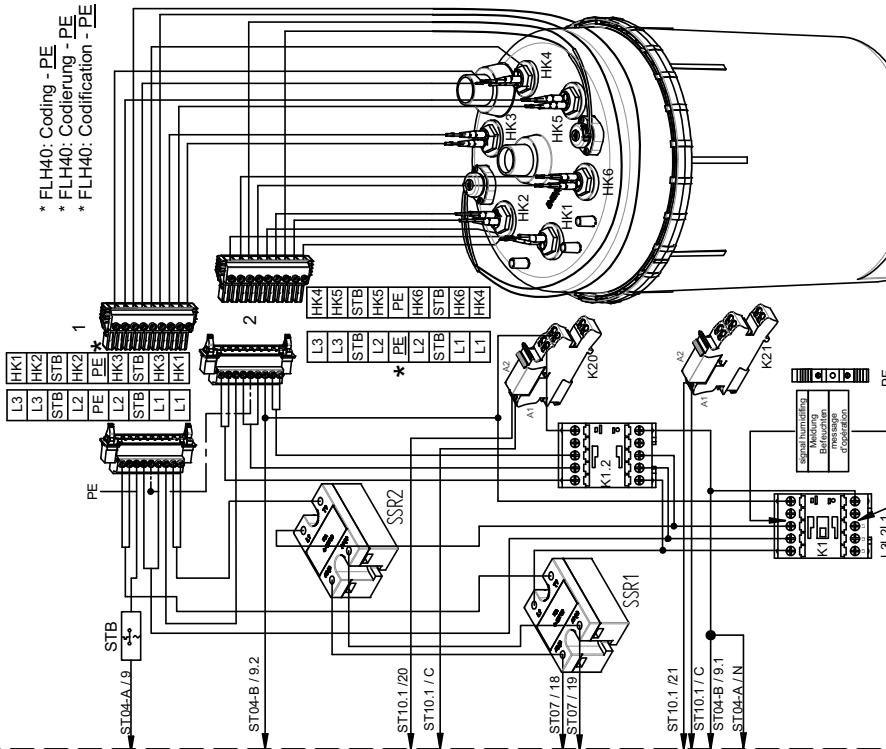

* FLH40: Coding - PE
 * FLH40: Codierung - PE
 * FLH40: Codification - PE

HYGROMATIK
 Lisa-Meiners-Str. 3
 24558 Henstedt-Ujzburg
 Tel.: +49(0)4193/895-0
 Fax: +49(0)4193/895-33

(Zeichnung Nr.)
S-43-015C.02

FLH 03-50
 heating voltage: 200 - 480V / 3

Rev.	Änderung	Datum	Name	Gepr.	Norm
A	release	11.11.17	Lue		
B	Steuerspa. int.	25.01.18	Lue		
C	HK Nr./K	07.06.18	WI		

Datum: 24.09.2018
 Datum: 25.09.2018

SPA Option 24V

with relay board
mit Relais Platine
avec platine relais

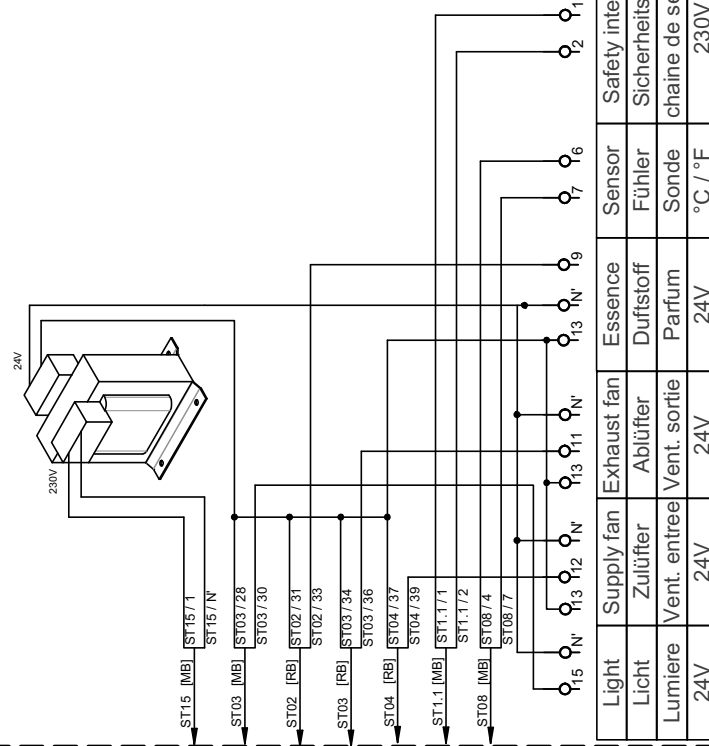

Light	Supply fan	Exhaust fan	Essence	Sensor	Safety interlock
Licht	Zulüfter	Ablüfter	Duftstoff	Fühler	Sicherheitskette
Lumiere	Vent. entree	Vent. sortie	Parfum	Sonde	chaîne de sécurité
24V	24V	24V	24V	°C / °F	230V

SPA Lite Option 24V

without relay board
ohne Relais Platine
sans platine relais

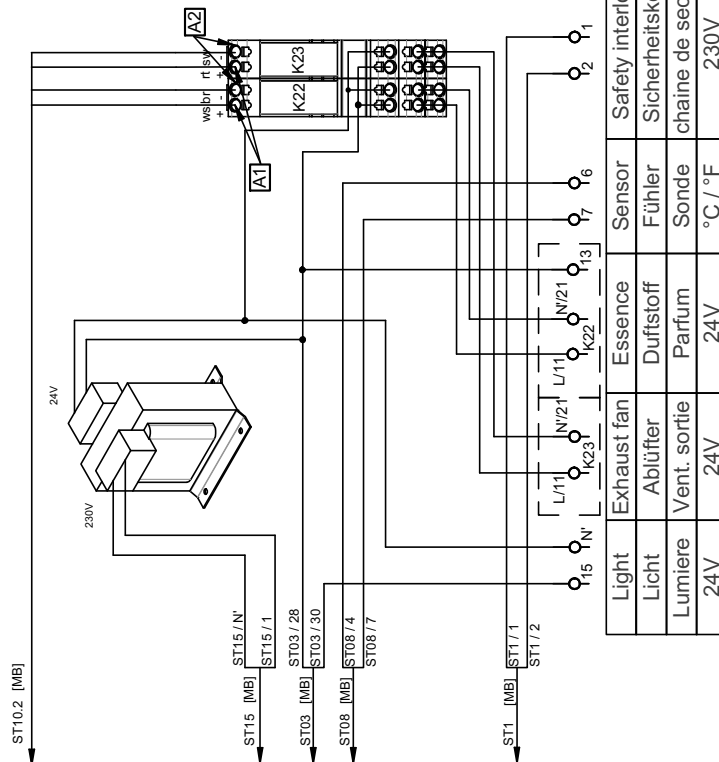

Light	Exhaust fan	Essence	Sensor	Safety interlock
Licht	Ablüfter	Duftstoff	Fühler	Sicherheitskette
Lumiere	Vent. sortie	Parfum	Sonde	chaîne de sécurité
24V	24V	24V	°C / °F	230V

A	release	21.06.18	WI	Datum	24.06.2018	SPA Option	(Zeichnung Nr.) S-43-015B.06
B	Terminal 19	24.09.18	Lue	Bearb.	Lue, 25.09.2018		
Rev.	Änderung	Datum	Name	Gepr.	Norm	control voltage: 24VAC 130VA	

HYGROMATIK
Lies-Melnes-Str. 3
24569 Herten-Ullring
Tel.: +49(0)4193/895-0
Fax: +49(0)4193/895-33

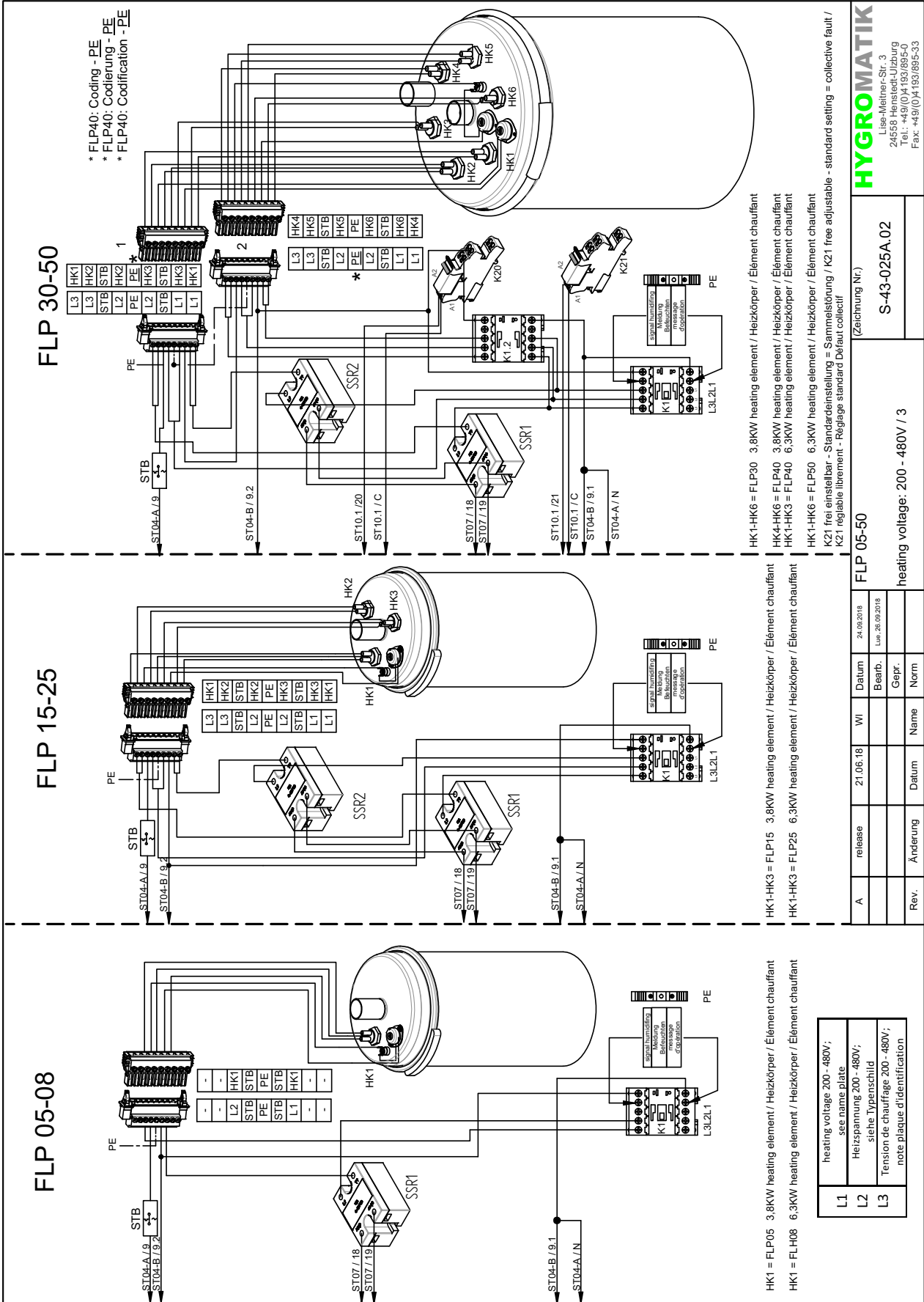

HYGROMATIK
 Lisa-Meiners-Str. 3
 24568 Henstedt-Liżburg
 Tel. +49(0)4193/895-0
 Fax: +49(0)4193/895-33

(Zeichnung Nr.)
S-43-025A.02

FLP 05-50
 heating voltage: 200 - 480V / 3

Rev.	Änderung	Datum	Name	Gepr.	Norm
A	release	21.06.18	Wi	Datum	24.09.2018
				Bearb.	26.09.2018

8.6 FLP - Option 24V

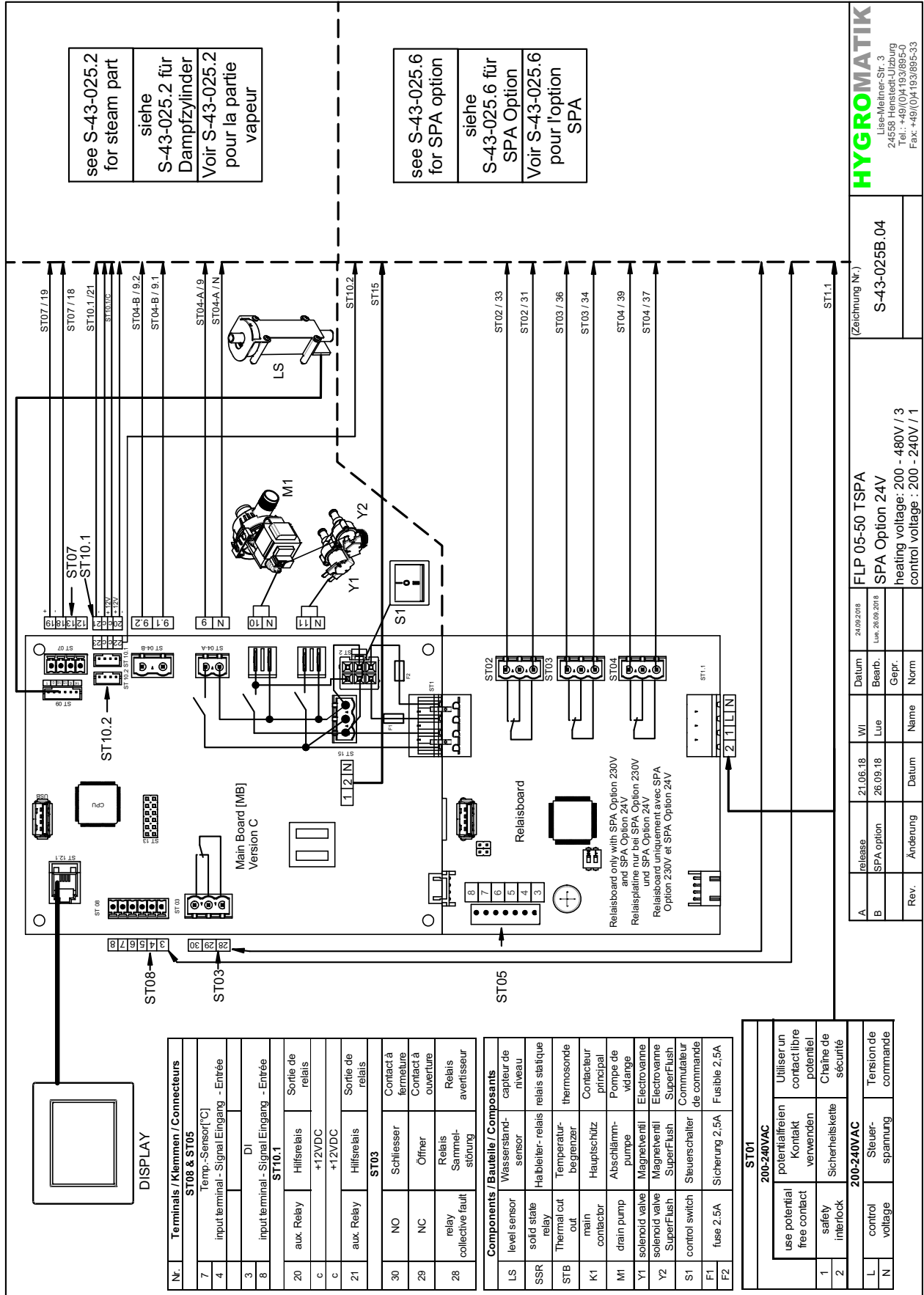

see S-43-025.2 for steam part
siehe S-43-025.2 für Dampfzylinder
Voir S-43-025.2 pour la partie vapeur

see S-43-025.6 for SPA option
siehe S-43-025.6 für SPA Option
Voir S-43-025.6 pour l'option SPA

HYGROMATIK
Lise-Melner-Str. 3
24558 Henstedt-Ubbung
Tel.: +49(0)4193/895-0
Fax: +49(0)4193/895-33

(Zeichnung Nr.)
S-43-025B.04

FLP 05-50 TSPA
SPA Option 24V
heating voltage: 200 - 480V / 3
control voltage : 200 - 240V / 1

Rev.	Änderung	Datum	Name	Norm
A	release	21.06.18	WI	
B	SPA option	26.09.18	Lue	

Nr.	Terminals / Klemmen / Connecteurs
ST08 & ST05	
7	Temp.-Sensor(°C)
4	input terminal - Signal Eingang - Entrée
DI	
3	input terminal - Signal Eingang - Entrée
ST10.1	
20	aux Relay
C	Hilfsrelais
	Sortie de relais
	+12VDC
C	+12VDC
21	aux Relay
	Hilfsrelais
	Sortie de relais
ST03	
30	NO
	Schliesser
	Contact à fermeture
29	NC
	Öfner
	Contact à ouverture
28	Relais
	Relais
	Sammel-
	störung
	avertisseur

Composants / Bauteile / Composants	Wasserstand- sensor	Halleiter- relais	thermosonde	Contacteur principal	Pompe de vidange	Electrovanne	Electrovanne SuperFlush	Commutateur de commande	Fusible 2,5A	Fusible 2,5A									
LS	level sensor	SSR	solid state relay	STB	Thermal cut main	K1	Hauptschutz contactor	M1	drain pump	Y1	solenoid valve	Y2	Magnetventil SuperFlush	S1	control switch	F1	fuse 2.5A	F2	fuse 2.5A

200-240VAC	
1	potential free contact
2	safety interlock
200-240VAC	
L	control voltage
N	Steuerspannung
	Tension de commande

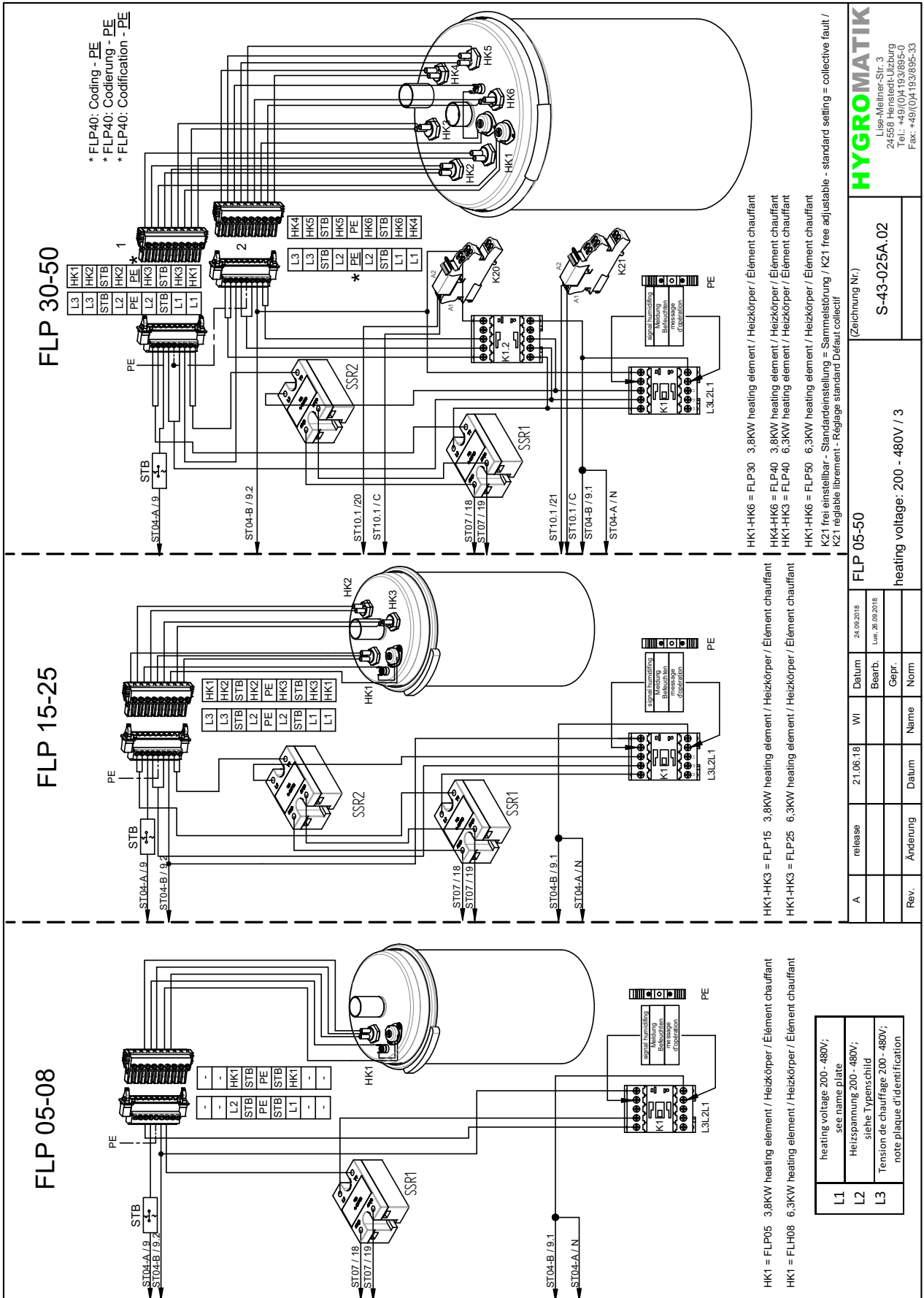

L1	heating voltage 200 - 480V; see name plate
L2	Heizspannung 200 - 480V; siehe Typenschild
L3	Tension de chauffe 200 - 480V; note plaque d'identification

HYGROMATIK
 Lise-Meiner-Str. 3
 24559 Hohenstedt-Lübzig
 Tel.: +49(0)4193/895-0
 Fax: +49(0)4193/895-33

(Zeichnung Nr.)
S-43-025A.02

Rev.	Änderung	Datum	Name	Gepr.	Norm
A	release	21.06.18	WI	Datum 24.02.2018 Beerb. Lith. 28.09.2018	

SPA Option 24V

with relay board
mit Relais Platine
avec platine relais

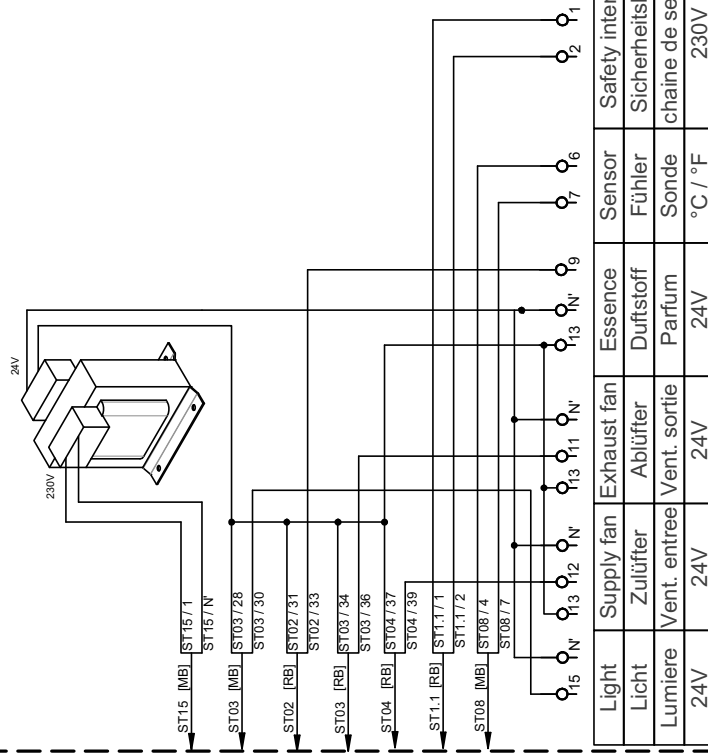

Light	Supply fan	Exhaust fan	Essence	Sensor	Safety interlock
Licht	Zulüfter	Ablüfter	Duftstoff	Fühler	Sicherheitskette
Lumiere	Vent. entree	Vent. sortie	Parfum	Sonde	chaîne de sécurité
24V	24V	24V	24V	°C / °F	230V

SPA Lite Option 24V

without relay board
ohne Relais Platine
sans platine relais

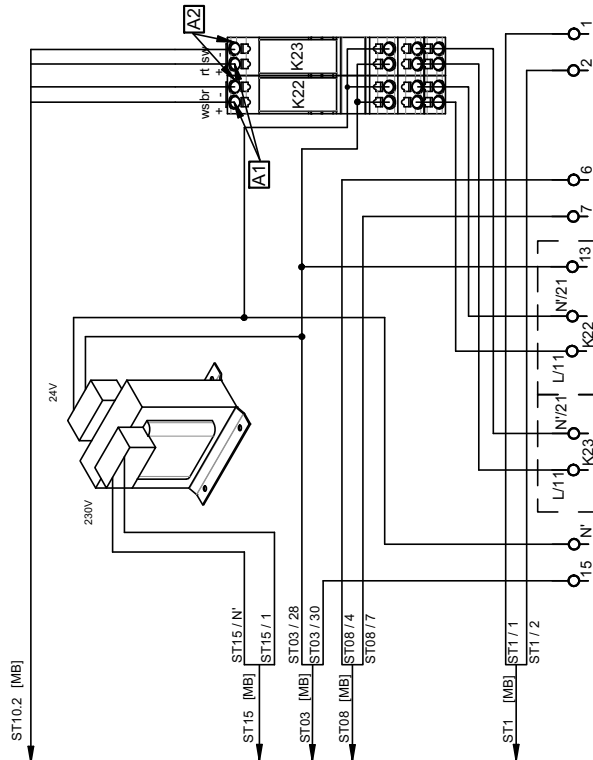

Light	Exhaust fan	Essence	Sensor	Safety interlock
Licht	Ablüfter	Duftstoff	Fühler	Sicherheitskette
Lumiere	Vent. sortie	Parfum	Sonde	chaîne de sécurité
24V	24V	24V	°C / °F	230V

A	release	21.06.18	WI	Datum	21.09.2018	SPA Option	(Zeichnung Nr.)	S-43-025B.06
	B	SPA option	26.09.18	Lue	Bearb.			
Rev.	Änderung	Datum	Name	Gepr.	Norm	control voltage: 24VAC 130VA		

HYGROMATIK
Lise-Meiner-Str. 3
24568 Hersted-Lübzig
Tel.: +49(0)4193/895-0
Fax: +49(0)4193/895-33

9. Glossary

Term	[Index]	Explanation
Actual value	1	The actual value is the measured value of a physical quantity, which is compared with the →Set value [3] during the control process and may give rise to a readjustment, if required.
Set value	3	The set value of a physical quantity (e.g. the temperature) is the set target for a control process.
Steam output	4	The steam output calculated from the electrical power consumption in kg/h.
Demand	5	The demand describes the dimensionless control signal processed by the control system which is converted into a proportional →Internal actuator signal [42] for the power control for steam generation.
Update function	7	The update function provides the control with an update of parameter settings which is stored on an external USB memory stick. The "Update function" parameter is a read-only value which can be used to read out the status of the update.
SI system of units	8	The system of units with the temperature specified in °C and the quantity specified in kg.
Imperial system of units	9	The system of units used in the USA with the temperature specified in °F (Fahrenheit) and the quantity specified in lbs or tn.sh. .
Initialisation	10	The control performs a self-test, during which the welcome screen with the software version is displayed. After the parameter settings and measured values have been read in, the →Main screen [14] is shown on the display. During the subsequent start blow-down, the read values can be used to query the device status, which is "Initialisation" in this phase.
Interlock (safety) system	11	The hardware interlock (safety) system makes it possible to immediately interrupt steam production, e.g. using an emergency stop button. The interlock (safety) system must be closed to operate the unit. The interlock (safety) system must be implemented on-site with one or several potential free contacts (switched in series). It is connected to the control at terminals 1 and 2, with terminal 1 carrying 230 VAC as standard. In a special design (e.g. for the U.S. market), the interlock (safety) system is converted to low voltage through the additional use of a relay to meet local safety requirements. Instead of terminals 1 and 2 on the control, a potential free connection of the relevant DIN rail terminals must then be implemented on-site. If the interlock (safety) system is opened, the status of the unit changes to "Interlock (safety) system open".
Software control command	12	Coded command, which is, for example, sent from the building control system or a PLC via the →Communication interface [13] to the control. The command set available is listed in separate documentation, which is available from HygroMatik on request.
Communication interface	13	Serial computer interface for remote control of the unit using, for example, the →Modbus [17] RTU protocol.
Main screen	14	Screen content during the normal operation of the unit. The main screen includes the main display (in the middle of the screen) and the status icons (left and right of the main display).
Standby heating	16	So that steam production can be started more quickly, the standby heating keeps the water in the cylinder warm, if no →Demand [5] is present. The →Interlock (safety) system [11] must be closed. Heating and pause times are adjustable.
Timer function	18	The timer makes it possible to limit the duration of steam production in the short-time range, starting when steam production is halted (if no demand exists in normal operation), or ECO mode . The timer is triggered by pressing a button, which must be connected to the digital input [97] of the mainboard. In addition, the →Digital function [98] parameter must be set to "Timer_start". The "0" setting deactivates the timer. "1" or "2" is used to specify whether the steam is turned off or if there is a return to ECO mode after the timer has elapsed.
Solenoid valve (SV)	19	The solenoid valves for the water supply to the steam cylinder(s) are labelled with Y1, Y2, Y3 and Y4 in the circuit diagrams.
Start blow-down	20	The unit performs a →Blow-down [58] after it was switched off and has been switched on again. The process varies depending on the unit type. For the →ELDB [77] it is important that, when the main contactor is first switched, overcurrent due to excessive conductivity of the cylinder water does not occur while simultaneously water level is high. A →Partial blow-down [21] is therefore used to ensure that the current does not reach an impermissible value. This procedure is not required for the →HKDB [78]. The only checks carried out here are on the functioning of the level control and the blow-down pump, by carrying out a plausibility check of the measured value of the water level sensor which is transferred in the context of a →partial blow-down [21].
Partial blow-down	21	Only part of the cylinder water is pumped off during the →Blow-down [58]. For the →ELDB [77], a partial blow-down is carried out periodically after 40 solenoid valve operating cycles (fillings), when the standard setting is left untouched. For the →HKDB [78], the frequency of the partial blow-down is determined by the steam volume.
Full blow-down	22	All of the cylinder water is pumped off during the →Blow-down [58].
Dilution	23	A dilution is a →Partial blow-down [21], which is caused by excessive conductivity of the cylinder water. For deconcentration, fresh water is used to top up the cylinder after the partial blow-down.
Overcurrent blow-down	24	Depending on the selection of the →Control curve, the current is increased to 128% or 113% of the nominal current during a cold start, in order to achieve a quick start characteristic. When the respective current value has been reached, the overcurrent blow-down is started causing the nominal current to revert to the normal value (only for →ELDB [77]).
Max. level blow-down	25	When the water level sensor signals the maximum level, a →Partial blow-down [21] is carried out to reduce the water level (only for →HKDB [78]).
Stand-by blow-down	26	If the unit was switched on for an extended period without a →Demand [5] arising, or if the →Interlock (safety) system [11] was opened for an extended period, a (→Blow-down [58]) of the cylinder water is performed to prevent germ formation. The interval for triggering the blow-down is defined with the "Standby blow-down interval" parameter.
Flushing of dead-end line	27	When this function is activated, the feed water line is flushed during operation phases in which there are no requests in order to prevent germ formation. For this purpose, the inlet solenoid valve and the blow-down pump are activated at the same time. The "Flushing_of_dead-end_line_interval" parameter determines when flushing starts after a request was not received, the "Flushing_of_dead-end_line_duration" parameter determines how long flushing takes. The interlock (safety) system must be closed so that the inlet solenoid valve can be controlled ("partially automatic flushing of dead-end line").

Continuation of glossary (1)

Term	[Index]	Explanation
Manual blow-down	28	Pumping out of the cylinder water by touching the "Blow-down" icon on the screen or by a → <i>Software control command</i> [12] via the → <i>Communication interface</i> [13]. Repeated actuation or a corresponding → <i>Software control command</i> [12] switches the → <i>Blow-down function</i> [58] off again). The cylinder water may also be pumped by setting the control switch on the device front panel in the "II" position while the control remains switched off.
Thermo sensor	31	With the → <i>HKDB</i> [78], a thermo sensor is located on the cylinder cover, connected to the heater(s) via a capillary tube. A thermal switch is also arranged on every → <i>Solid state relay</i> [46]. All thermo sensors/thermal switches are connected in series. If one of the thermo sensors/thermal switches is triggered, the power supply to the steam humidifier is interrupted. The thermo sensor(s) on the cylinder(s) have to be reset mechanically after cooling down. The thermal switches are automatically reset after cooling down.
Limitation of operating time	32	The unit stops the steam production according to the number of minutes specified. The time is counted from the point when the interlock (safety) system was closed. To put the unit back into operation, the interlock (safety) system must be opened and closed again, or the → <i>Communication interface</i> [13] must be used to transmit → <i>Software control commands</i> [12] to open and close the virtual interlock (safety) system again. Alternatively, the control switch can also be opened and closed again. This does, however, cause the unit to be restarted. Setting the parameter to a value of "0" deactivates the limitation of operating time.
Steam_amount_service	33	The steam volume produced [kg] is compared to the default value set in the "Steam_amount_service" parameter to obtain a criterion for maintenance requirements. Once the default value has been reached, the message "Steam_amount_counter" is displayed. Once the service has been performed, the steam volume counter has to be reset with "Service_reset_cyl. x". The remaining steam volume can be viewed using the "Steam_until_msg_cyl. x" read value.
Service_main_contactor	34	The operating cycles of the main contactor(s) are recorded by counters and compared to factory-set default values by the software. When a default value is reached, the "Service_main_contactor x" message is displayed on the screen. After a main contactor has been replaced, the respective counter must be reset with the parameter "Main_contactor_x_Reset" (x = number of the main contactor, 1...5).
Cylinder full status	38	When the unit measures a voltage at the sensor electrode, it reports a cylinder full status. In this case, the cylinder water level is so high that it creates an electrical bridge between one of the power electrodes and the sensor electrode. If the cylinder full status continues for an hour, steam production is shut down and a fault message is generated.
Level control	39	With the → <i>HKDB</i> [78], communicating tubes are used for the contact-free measurement of the water level in the cylinder.
Max. level	40	The maximum water level value supplied by the → <i>Level control</i> is reached. If this state is reached 5x in succession within a predefined time interval, the control issues a "Error_max.level" message (only → <i>HKDB</i> [78]).
Max. temperature	41	Maximum steam bath temperature where, once reached, the unit switches off for safety reasons. This is set using the differential value ? Max temp. in "K" (corresponding to °C), which must be added to the temperature target value to determine the absolute switch-off temperature.
Internal actuator signal	42	Actuator signal for the control of the power element of the unit concerned.
Max. steam output	43	Reduction of output power to 25... 100% of the nominal output. Can lead to improved control behaviour at lower output requirements.
1 step operation	44	On/off operation of the steam generator without control function through a potential free contact suitable for low voltage, to be supplied on-site.
Second temperature sensor	45	<p>For enhancement of the temperature measurement reliability or the consideration of the influences introduced by on-site particularities, the control may be operated with a 2nd temperature sensor. Prerequisite is the unit's configuration level with an expansion board or a relay board in addition to the mainboard. The 2nd sensor is connected to the relevant connector plug on the respective p.c.b., just as the 1st sensor is. Activation of the 2nd sensor is made by setting the "Sensor_2_connection" parameter within the "SPA" submenu to setting variant "Cylinder extension" or "Relay 1 extension" (De-activation is accomplished by</p> <ol style="list-style-type: none"> 1. Averaging the readings of both sensors with a defined weighting 2. Comparison of the two readings and generation of a fault message in case of deviation <p>Selection processing method is made by setting the "Temperature_measurement" parameter within the "SPA" submenu. Setting options are "Average" and "Deviation". Averaging takes both measurements in concern for forming a new value that is relevant for further processing. "Sensor_1_weighting" with a 0 to 100% range defines the impact of each of the sensors on the total result.</p> <p>Scaling is as such: "0%" = only the sensor 2 measurement value is taken into account "50%" = the measurement values of both of the sensors determine the average value with an identical weighting "100%" = only sensor 1 measurement value is taken into account</p> <p>When "Deviation" is selected, only the sensor 1 measurement value is processed, as long as a significant deviation is not detected. However, when a significant has occurred, the fault message "Deviation" is generated. The criterion for this message is the degree of deviation that may be set as the "Sensors_deviation" parameter (s. SPA submenu) between 1.0K and 10.0K.</p>
Solid state relay (SSR)	46	Electronical power switch mounted on a thermally monitored heat sink (only → <i>HKDB</i> [78]).

Continuation of glossary (2)

Term	[Index]	Explanation
Humidification	47	The unit produces steam, if a temperature sensor has issued a →Demand [5] and the →Interlock (safety) system [11] is closed.
PWM	48	Pulse width modulation with variable frequency and variable duty cycle for the control of the heater current via the →Solid state relay [46]. Because the heater current determines the steam output, it is possible to control the steam output in this way (only for →HKDB [78]).
Δ Temp._ECO	52	To save energy, the ? set value of the steam bath can be lowered by the value stored in "? Temp._ECO". For this purpose, a →pushbutton [106] has to be wired to the ?Digital input and the function of the digital input has to be programmed to "ECO".
Steam_down_time_to_fault	53	If the level of the cylinder water has not changed within the time defined in this parameter, this indicates that a malfunction is present. The steam production is then suspended and the "Steam_down_time" fault message is output (only →HKDB [78]).
Filling_cycled	54	The fill operation does not take place continuously, but with breaks, in order to prevent the overflowing of the filling cup (HyFlow). Filling and pause intervals can be adjusted separately.
Blow-down correction	55	If the water has high electrical conductivity or if there is a very high level of maintenance, it may be useful to increase the blow-down frequency. At low electrical conductivity, however, a reduction in the frequency of the blow-down may be useful. Depending on the water quality, the blow-down rate can be adjusted in 10 steps ("0" is the default). More frequent blow-down: Values up to max. +5, less frequent blow-down values down to -5, whereby "-5" means that blow-down is completely switched off.
Pumps_without_main_contactor	56	In rare cases, leakage currents may flow through the water to the earth during the blow-down process. To prevent a sensitive fault current circuit breaker from tripping, the main contactor can be switched off during the pumping process (only →ELDB [77]).
HyFlush (option)	57	When open, an additional solenoid valve produces a rotating turbulence for an improved discharge of scale deposits during blow-down. The solenoid valve is controlled by the software with a fixed ratio of active and pause times.
Blow-down	58	Pumping off the water in the cylinder for the following reasons: Elimination of scale deposits, replacement of water to prevent germ formation and reduction of conductivity (only →ELDB [77]), which increases due to evaporation and leads to increased power consumption. A distinction is made between →Full blow-down
Steam jet activation	60	A steam jet can be triggered manually if a →button [106] intended for this purpose is wired between the →Auxiliary voltage [105] at Pin 3 of ST08 (mainboard) or ST05 (relay board) and the →Digital input [97], and the →Digital_input_function [98] has been programmed to "Steam_boost". When triggered, the steam bath set temperature is increased in the short term to a value which results from the set temperature + ? steam_boost. The duration of the target temperature increase is determined by the "Steam_jet_duration" parameter. The value of the "Steam_jet_blocking" parameter determines the time between the last steam jet and when the next steam jet can take place.
ECO mode	61	Reduction of →Temperature set value [3] to conserve energy.
Power level	63	If the →HKDB [78] is equipped with more than 3 heaters, the power is provided in 2 levels from a certain performance class onwards. As long as a certain threshold value has not been reached, the heating performance required is exclusively controlled via the →Solid state relay [46] and 3 heater elements by means of proportional control (stage 1). If the output power demand exceeds the power available in stage 1, 3 more heater elements are additionally switched on in a 1-step mode (stage 2). The power demand beyond what is available in stage 2 is then covered in stage 1 by the solid state relay driven in proportional mode.
Relay assignment	65	If the basic relay or additional relays which may be present are not used for signalling but for direct load switching, the maximum contact load 250 VAC/8 A must be taken into account
Power retention	66	After the set temperature has been reached, power is reduced to between 1 and 50% of the nominal output which was provided previously. The "0" setting means that the function is switched off. The original power is resumed when the temperature falls below the target temperature.
Control curves	68	In the "Load optimised" factory setting, the power control of an →ELDB [77] is set so that a current of 113% of the nominal current is permitted during a cold start to avoid overloading the power supply. In the "Energy optimised" setting, the current is increased to 128% of the nominal current during a cold start for achievement of a preferably short heat-up period. In the "Process optimised" setting, control is particularly fine.
Output signal	69	Signal 0... 10 V on terminals 12 and 13 (GND), which is proportional to the input signal. Can be used to control downstream units.

Continuation of glossary (3)

Term	[Index]	Explanation
Fan control	71	<p>The control may switch 2 supply fans and 2 exhaust fans with the respective 2nd fan adding an additional performance level (in case of two-stage fans the 2nd performance level is already integrated).</p> <p>When in "Auto" mode, the following mechanism controls the exhaust fans:</p> <ul style="list-style-type: none"> • Switch on exhaust fan 1 when the temperature set value is exceeded ($T_{actual} > T_{set}$) • Switch off exhaust fan 1 when the actual temperature has fallen below ($T_{actual} - \text{Exhaust fan } 1_{\Delta} \text{ Temp.}$) • Switch on exhaust fan 2 in addition to exhaust fan 1 (or 2nd performance level) when the actual steam bath temperature has reached ($T_{set} + \text{Exhaust fan } 2_{\Delta} \text{ Temp.}$) <p>Example: $T_{set} = 45^{\circ}\text{C}$, Exhaust fan $1_{\Delta} \text{ Temp} = 5\text{K}$, Exhaust fan $2_{\Delta} \text{ Temp} = 2\text{K}$ Exhaust fan 1 switches on, when the steam bath temperature exceeds 45°C Exhaust fan 1 switches off, when the steam bath temperature falls below 40°C Exhaust fan 2 is additionally switched on when the steam bath temperature exceeds 47°C Exhaust fan 2 switches off when the steam bath temperature falls below 40°C</p> <p>When in "Auto" mode, the following mechanism controls the supply fans:</p> <ul style="list-style-type: none"> • Switch on supply fans 1 and 2 as long as the actual steambath temperature has not yet reached the set value ($T_{actual} < T_{set}$) • Switch off supply fan 1 when the actual temperature has reached the ($T_{set} + \text{Supply fan } 1_{\Delta} \text{ Temp.}$) value <p>Example: $T_{set} = 45^{\circ}\text{C}$, Supply fan $1_{\Delta} \text{ Temp.} = 4\text{K}$, Supply fan $2_{\Delta} \text{ Temp.} = 2\text{K}$ Supply fans 1 and 2 switch on, as long as the steambath temperature is below 45°C Supply fan 2 switches off when the steambath temperature has reached 47°C Supply fan 1 switches off when the steambath temperature has reached 49°C</p>
Dropout delay	74	By assigning the "8" value to one of the relay contacts, a control signal for the delayed closing of a steam valve is made available for pressure reduction. The dropout delay is set with the "Humidification_off_delay" parameter. Factory default is 60 s.
Main contactor	75	The installed main contactors are labelled K1...K4. The operating cycles of the main contactor(s) are monitored and compared with the value specified by the manufacturer for the expected service life. When the stored value is reached, the message "Service_main_contactor" is generated. After the main contactor has been replaced, the status message must be deleted, for example using the $\rightarrow \text{Main_contactor_K1_Reset} = "1"$ parameter.
SPA_humidity	76	In "SPA-humidity" mode, relative humidity is maintained at 60% r.h. (factory setting) in contrast to a steam bath ("SPA_temperature" operating mode), where the r.h. is 100%. The temperature for "SPA-humidity" mode must be controlled on-site.
ELDB	77	Electrode steam humidifier.
HKDB	78	Heater steam humidifier.
SPA	80	Collective term for use of the unit as a steam bath and organic sauna
Stopping time	82	The temperature control has been stopped. This can be caused by the end of a time program or the opening of the safety chain or similar. The relevant supply and exhaust fans continue to run for the set follow-up time to support the drying of the steam bath.
Intensity	83	The intensity of the essence injection can be changed incrementally from 0... 10, where "0" switches off the respective essence.
Pause time	84	The time between two essence doses. Essence is only dosed when steam is also produced.
Dosage time	85	The duration of an essence dose.
Virtual interlock (safety) system	86	If control via $\rightarrow \text{Communication interface [13]}$ was selected, software is used to place a logical switch in series with the hardware interlock (safety) system. This switch can be opened and closed via $\rightarrow \text{Software commands [12]}$. If the hardware interlock (safety) system is closed and the switch is opened via software control command, steam production is stopped and the unit is placed in "Remote switch-off" status.
Supply voltage	89	The units are designed for connection to supply voltage ranges (e.g. 380 to 415 VAC in case of a 400 VAC unit, s. name plate)
Unit name	90	Here, "Plant 1" is entered by default.
Weekly timer	91	The timer makes it possible to program 2 periods per day of the week, each defined by a start time and an end time. The temperature set value and an essence dose can be preset for each time period.
Temperature threshold value	92	If the specified threshold value has been reached, the relay which is intended for this purpose is energised. The assignment of this relay must be "256 = Message_Temp.-threshold_value".
Recording	93	The control can record 10 data sets internally on a rolling basis. Snapshots of the unit status are carried out at intervals of 10 s, which can be helpful for troubleshooting. When the storage space is filled, a new set of data overrides the oldest entry. The complete record can be saved to a USB stick with NTFS formatting.
Warning message	95	The electrodes (for the $\rightarrow \text{ELDB [77]}$), the blow-down pump and the solenoid valves are items with limited service life due to wear and tear. They must be checked during maintenance works and replaced if required. To avoid unplanned maintenance requirements, alerts can be set up for the respective items, which are activated when a defined state of wear is reached. The criteria for the alerts to be triggered can be defined in three stages each through the sensitivity setting.
PI controller	96	Internal controller with control characteristics which contain a Proportional part and an Intergal part. Both parts can be changed as parameters.

Continuation of glossary (4)

Term	[Index]	Explanation
Digital input	97	Digital input on the mainboard and on the relay boards for switching functions. A logical meaning (e.g. timer start) is assigned to the digital input via the → <i>Digital_input_function</i> [98] parameter. The digital input must be wired on-site in accordance with its use, e.g. with a → <i>Pushbutton</i> [106] or a → <i>Switch (NO)</i> [102] against the 20 VDC on terminal 8 on the mainboard terminal strip ST08 or the terminal strip ST05 on the other available boards. When the 20 VDC voltage is applied (short-term via a → <i>Pushbutton</i> [106] or permanent via a → <i>Switch (NO)</i> [102]), as required in accordance with → <i>Digital_input_function</i> [98] parameter setting), the switching function is carried out.
Digital_input_function	98	Determines which function will be executed if the → <i>Digital input</i> [97] on the mainboard or one of the relay boards is loaded externally with level "1" (= 12 V).
Nominal power output	99	The steam output range given on the name plate derived from the allowable range of supply voltages
Power section	100	That part of the unit that makes the energy conversion from the current supplied into steam output
Load shedding	101	Load shedding can be set up by assigning the → <i>Function_digital_input</i> [98] "Power limitation" to the → <i>Digital input</i> [97]. When the → <i>Digital input</i> [97] is then then connected to an → <i>Auxiliary voltage</i> [105] by means of a → <i>Switch (NO)</i> [102], → <i>Max. steam output</i> [43] is reduced by the percentage set up in the "Δ power limitation" parameter. After withdrawal of the voltage normal operation is reestablished.
Switch (NO)	102	Electrical switch with N ormally O pen contacts
Steam_down_time_min.	103	Steam-down time between fillings is continuously monitored. If the minimum steam-down time set falls below the value set up several times in a row, an indication exists that the cylinder water conductivity has risen to an extend non tolerable. For conductivity reduction, → <i>Dilution</i> [23] is triggered (only → <i>ELDB</i> [77]).
Slave_hysteresis	104	In order to avoid unnecessary frequent switching on and off of → <i>Slave</i> [94] units (as required by the output demand) or an oscillating tendency, switching is made with a hysteresis. Example: One Master controls one Slave. Switching on the slave without hysteresis would occur at 50% output demand, same situation for switching the slave off. With a 1% hysteresis, switching on the slave is at 51% output demand whereas switching off is at 49%. By this, instability of the switch-off point is accomplished.
Push button	106	Electrical switch for momentary action
Fully automatic deadleg flushing	107	For "fully automatic" → <i>Deadleg flushing</i> [27], an additional relay must be implemented that allows for switching the intake solenoid valve even when the → <i>Interlock (safety) system</i> [11] is open. Control of this additional relay is either by the base relay on the mainboard or a coupling relay. The relay used for this function must have "68" as the assignment.

10. Technical data

FLE Steam Humidifier Spa

Technical specifications FlexLine electrodes						
Unit type	FLE05	FLE10	FLE15	FLE20	FLE25	FLE30
Steam output [kg/h]	4,7 - 5,0 - 5,2	9,5 - 10,0 - 10,4	14,2 - 15,0 - 15,5	19,0 - 20,0 - 20,8	23,8 - 25,0 - 26,0	28,5 - 30,0 - 31,1
Electrical connection ⁽¹⁾	380 - 400 - 415V /3Ph /N /50-60Hz					
Rated power [kW]	3,6 - 3,7 - 3,9	7,1 - 7,5 - 7,8	10,7 - 11,2 - 11,6	14,3 - 15 - 15,6	17,8 - 18,8 - 19,5	21,4 - 22,5 - 23,4
Nominal current [A]	5,4 - 5,4 - 5,4	10,8 - 10,8 - 10,8	16,2 - 16,2 - 16,2	21,7 - 21,7 - 21,7	27,1 - 27,1 - 27,1	32,5 - 32,5 - 32,5
Fuse [A] ⁽²⁾	3 x 10	3 x 16	3 x 20	3 x 32		3 x 40
Terminals max. [mm ²]	4			10		
Number of steam cylinder	1					
Control	FlexLine mainboard with capacitive 3.5" touch colour display					
Separate control voltage ⁽³⁾	220 - 240V 2,5A					
Steam hose connection [mm]	1 x 40			1 x 40		
Water consumption ⁽⁷⁾ [l/h]	6,2	12,5	18,6	25,0	31,2	37,3
Water flow rate ⁽⁸⁾ [l/min]	1,3 / 20,5		2,8 / 22,0			4,1 / 23,3
Max. filling capacity [l]	4,8		13,2			20,9
Empty weight [kg]	16,0		22,0		23,0	26,0
Operation weight [kg]	21,3		35,7		36,7	47,4
Width ⁽⁹⁾ [mm]	540					580
Height ⁽⁹⁾ [mm]	535		695			750
Depth ⁽⁹⁾ [mm]	320					355
Water connection	tap water of varying qualities 1 to 10bar, 1 to 10 bar, for 3/4" external thread					
Drain water connection	Connection Ø 1 1/4"					

Technical specifications FlexLine electrodes						
Unit type	FLE40	FLE50	FLE65	FLE80	FLE100	FLE130
Steam output [kg/h]	38,0 - 40,0 - 41,5	47,5 - 50,0 - 51,8	61,8 - 65,0 - 67,5	76,0 - 80,0 - 83,0	95,0 - 100,0 - 104,0	124,0 - 130,0 - 135,0
Electrical connection ⁽¹⁾	380 - 400 - 415V /3Ph /N /50-60Hz					
Rated power [kW]	28,5 - 30 - 31,1	35,6 - 37,5 - 38,9	46,3 - 48,8 - 50,6	2 x 28,5 - 30 - 31,1	2 x 35,6 - 37,5 - 38,9	2 x 46,3 - 48,8 - 50,6
Nominal current [A]	43,3 - 43,3 - 43,3	54,1 - 54,1 - 54,1	70,4 - 70,4 - 70,4	2 x 43,3 - 43,3 - 43,3	2 x 54,1 - 54,1 - 54,1	2 x 70,4 - 70,4 - 70,4
Fuse [A] ⁽²⁾	3 x 50	3 x 63	3 x 80	2 x 3 x 50	2 x 3 x 63	2 x 3 x 80
Terminals max. [mm ²]	16	25		16	25	
Number of steam cylinder	1			2		
Control	FlexLine mainboard with capacitive 3.5" touch colour display					
Separate control voltage ⁽³⁾	220 - 240V 2,5A					
Steam hose connection [mm]	2 x 40 ⁽⁶⁾	2 x 40		4 x 40 ⁽⁶⁾	4 x 40	
Water consumption ⁽⁷⁾ [l/h]	49,8	62,2	81	99,6	124,8	162,0
Water flow rate ⁽⁸⁾ [l/min]	4,1 / 23,3			2 x 4,1 / 23,3		
Max. filling capacity [l]	35,7		41,8	71,4		
Empty weight [kg]	25,0	33,0	34,0	66,0	75,0	
Operation weight [kg]	46,4	69,2	70,2	108,3	146,9	
Width ⁽⁹⁾ [mm]	640			1130	1170	
Height ⁽⁹⁾ [mm]	785			750	785	
Depth ⁽⁹⁾ [mm]	420					
Water connection	tap water of varying qualities 1 to 10bar, 1 to 10 bar, for 3/4" external thread					
Drain water connection	Connection Ø 1 1/4"			2x Connection Ø 1 1/4"		

⁽¹⁾ Other voltages upon request.

⁽²⁾ 13/28% above nominal power consumption after full blowdown. Observe actuation characteristics of automatic circuit-breakers.
If necessary, select the next highest circuit-breaker level.

⁽³⁾ Internal control voltage upon request.

⁽⁶⁾ Incl. Y-piece DN40.

⁽⁷⁾ Maximum water consumption at 100% demand plus blowdown losses. The water consumption depends on the water quality and installed options.

⁽⁸⁾ Flow rate of the feed water during refilling or pumping out. Unit without options / maximum rate with options.

⁽⁹⁾ Outer dimensions of width and depth. Height incl. drain connection.

FLH Steam Humidifier Spa

Technical specifications FlexLine heater				
Unit type	FLH06	FLH09	FLH15	FLH25
Steam output [kg/h]	5,4 - 6,0 - 6,5	8,1 - 9,0 - 9,7	13,7 - 15,0 - 16,4	22,7 - 25,0 - 27,1
Electrical connection ⁽¹⁾	380 - 400 - 415V /3Ph /N /50-60Hz			
Rated power [kW]	4,1 - 4,5 - 4,8	6,1 - 6,8 - 7,3	10,3 - 11,4 - 12,3	17,1 - 18,9 - 20,3
Nominal current [A]	10,7 - 11,3 - 11,7	16 - 16,9 - 17,5	15,6 - 16,5 - 17,1	25,9 - 27,3 - 28,3
Fuse [A]	3 x 16	3 x 20		3 x 32
Terminals max. [mm ²]	4		10	
Number of steam cylinder	1			
Control	FlexLine mainboard with capacitive 3.5" touch colour display			
Separate control voltage ⁽³⁾	220 - 240V 2,5A			
Steam hose connection [mm]	1 x 40			1 x 40
Water consumption ⁽⁷⁾ [l/h]	7,8	11,6	19,7	32,5
Water flow rate ⁽⁸⁾ [l/min]	1,3 / 20,5		2,8 / 22,0	
Max. filling capacity [l]	4,8		14,0	
Empty weight [kg]	18,0		25,0	
Operation weight [kg]	23,3		39,5	
Width ⁽⁹⁾ [mm]	540			
Height ⁽⁹⁾ [mm]	535		695	
Depth ⁽⁹⁾ [mm]	320			
Water connection	fully demineralised water / cleaned condensate / partially softened tap water of varying qualities 1 to 10 bar, 1 to 10 bar, for 3/4" external thread			
Drain water connection	Connection Ø 1 1/4"			

Technical specifications FlexLine heater					
Unit type	FLH30	FLH40	FLH50	FLH80	FLH100
Steam output [kg/h]	27,4 - 30,0 - 32,7	36,5 - 40,0 - 43,5	45,5 - 50,0 - 54,3	72,9 - 80,0 - 87,0	91,0 - 100,0 - 108,5
Electrical connection ⁽¹⁾	380 - 400 - 415V /3Ph /N /50-60Hz				
Rated power [kW]	20,6 - 22,8 - 24,5	27,3 - 30,3 - 32,6	34,1 - 37,8 - 40,7	2 x 27,3 - 30,3 - 32,6	2 x 34,1 - 37,8 - 40,7
Nominal current [A]	31,2 - 32,9 - 34,1	41,5 - 43,7 - 45,4	51,8 - 54,6 - 56,6	2 x 41,5 - 43,7 - 45,4	2 x 51,8 - 54,6 - 56,6
Fuse [A]	3 x 35	3 x 50	3 x 63	2 x 3 x 50	2 x 3 x 63
Terminals max. [mm ²]	35				
Number of steam cylinder	1			2	
Control	FlexLine mainboard with capacitive 3.5" touch colour display				
Separate control voltage ⁽³⁾	220 - 240V 2,5A				
Steam hose connection [mm]	1 x 40 ⁽⁶⁾	2 x 40		4 x 40	
Water consumption ⁽⁷⁾ [l/h]	39,2	52,2	65,2	104,4	130,2
Water flow rate ⁽⁸⁾ [l/min]	4,1 / 23,3			2 x 4,1 / 23,3	
Max. filling capacity [l]	36,0			71,4	
Empty weight [kg]	36,0	37,0		80,0	
Operation weight [kg]	72,5	73,5		151,9	
Width ⁽⁹⁾ [mm]	640			1170	
Height ⁽⁹⁾ [mm]	785				
Depth ⁽⁹⁾ [mm]	420				
Water connection	fully demineralised water / cleaned condensate / partially softened tap water of varying qualities 1 to 10 bar, 1 to 10 bar, for 3/4" external thread				
Drain water connection	Connection Ø 1 1/4"			2x Connection Ø 1 1/4"	

⁽¹⁾ Other voltages upon request.

⁽³⁾ Internal control voltage upon request.

⁽⁶⁾ Incl. Y-piece DN40.

⁽⁷⁾ Maximum water consumption at 100% demand plus blowdown losses. The water consumption depends on the water quality and

⁽⁸⁾ Flow rate of the feed water during refilling or pumping out. Unit without options / maximum rate with options.

⁽⁹⁾ Outer dimensions of width and depth. Height incl. drain connection.

FLP Steam Humidifier Spa

Technical specifications FlexLinePlus heater							
Unit type	FLP05	FLP08	FLP15	FLP25	FLP30	FLP40	FLP50
Steam output [kg/h]	4,6 - 5,0 - 5,5	7,6 - 8,0 - 9,0	13,7 - 15,0 - 16,4	22,7 - 25,0 - 27,1	27,4 - 30,0 - 32,7	36,5 - 40,0 - 43,5	45,5 - 50,0 - 54,3
Electrical connection ⁽¹⁾	380 - 400 - 415V /3Ph /N /50-60Hz						
Rated power [kW]	3,4 - 3,8 - 4,1	5,7 - 6,3 - 6,8	10,3 - 11,4 - 12,3	17,1 - 18,9 - 20,3	20,6 - 22,8 - 24,5	27,3 - 30,3 - 32,6	34,1 - 37,8 - 40,7
Nominal current [A]	9 - 9,5 - 9,9	15 - 15,8 - 16,3	15,6 - 16,5 - 17,1	25,9 - 27,3 - 28,3	31,2 - 32,9 - 34,1	41,5 - 43,7 - 45,4	51,8 - 54,6 - 56,6
Fuse [A]	3 x 16	3 x 20	3 x 20	3 x 32	3 x 35	3 x 50	3 x 63
Terminals max. [mm ²]	4		10			35	
Number of steam cylinder	1						
Control	FlexLine mainboard with capacitive 3.5" touch colour display						
Separate control voltage ⁽³⁾	220 - 240V 2,5A						
Steam hose connection [mm]	1 x 40			1 x 40	1 x 40 ⁽⁶⁾	2 x 40	
Water consumption ⁽⁷⁾ [l/h]	6,6	10,8	19,68	32,52	39,24	52,2	65,16
Water flow rate ⁽⁸⁾ [l/min]	2,8 / 22,0				4,1 / 23,3		
Max. filling capacity [l]	15,0				30,0		
Empty weight [kg]	32,0		35,0			41,0	
Operation weight [kg]	47,5		50,5			71,5	
Width ⁽⁹⁾ [mm]	650						
Height ⁽⁹⁾ [mm]	855						
Depth ⁽⁹⁾ [mm]	380						
Water connection	fully demineralised water / cleaned condensate / partially softened tap water of varying qualities ⁽¹⁰⁾ 1 to 10 bar, 1 to 10 bar, for 3/4" external thread						
Drain water connection	Connection Ø 1 1/4"						

⁽¹⁾ Other voltages upon request

⁽³⁾ Internal control voltage upon request

⁽⁶⁾ Incl. Y-piece DN40

⁽⁷⁾ Maximum water consumption at 100% demand plus blowdown losses. The water consumption depends on the water quality and installed options.

⁽⁸⁾ Flow rate of the feed water during refilling or pumping out. Unit without options / maximum rate with options.

⁽⁹⁾ Outer dimensions of width and depth. Height incl. drain connection.

HygroMATIK[®] SPA

HygroMatik GmbH
Lise-Meitner-Str. 3
24558 Henstedt-Ulzburg
Germany
T +49 4193 895-0
F +49 4193 895-33
hy@hygromatik.de
www.hygromatik.com
member of CAREL-group

