

### Electric Heater Steam Humidifier

# HeaterLine



**IMPORTANT: READ AND SAVE  
THESE INSTRUCTIONS**



HL.CSA  
E-8881708

Certain computer programs contained in this product [or device] were developed by HygroMatik GmbH ("the work(s)").

© Copyright HygroMatik GmbH

HeaterLine CSA [01.02.2017]

Current version of this manual can be found at: [www.hygromatik.de/us](http://www.hygromatik.de/us)

All rights reserved.

HygroMatik GmbH grants the legal user of this product [or device] the right to use the work(s) solely within the scope of the legitimate operation of the product [or device]. No other right is granted under this licence. In particular and without prejudice to the generality of the foregoing, the work(s) may not be used, sold, licensed, transferred, copied or reproduced in whole or in part or in any manner or form other than as expressly granted here without the prior written consent of HygroMatik GmbH.

Information in this manual is subject to change or alteration without prior notice.

**▲WARNING**

**Risk of electrical shock!**

Hazardous electrical high voltage!

All electrical work to be performed by certified expert staff (electricians or expert personnel with equivalent training) only. Disconnect power supply prior to work start

<b>1. Introduction</b> .....	<b>5</b>
1.1 Typographic Distinctions .....	5
1.2 Documentation .....	5
1.3 Symbols in Use .....	6
1.3.1 Specific Symbols related to Safety Instructions .....	6
1.4 Intended Use .....	6
<b>2. Safety Instructions</b> .....	<b>8</b>
2.1 Guidelines for Safe Operation .....	8
2.1.1 General .....	8
2.1.2 Unit control .....	8
2.1.3 Unit operation .....	8
2.1.4 Mounting, maintenance, repair and dismantling of the unit .....	9
2.1.5 Electrical .....	9
<b>3. Transport</b> .....	<b>10</b>
3.1 Overview .....	10
3.2 Transport Size and Weigth .....	10
3.3 Packing .....	11
3.4 Interim Storage .....	11
3.5 Check for Complete and Correct Delivery of Goods .....	11
3.6 Included in the Delivery .....	12
<b>4. Functional description and device composition</b> .....	<b>13</b>
4.1 Mode of operation .....	13
4.2 Structure and operation of the device .....	13
4.3 Internal Output Setting .....	15
<b>5. Installation</b> .....	<b>16</b>
5.1 Environment Parameters to be met and Mounting Recommendations .....	16
5.1.1 Fitting Measures .....	18
5.1.2 Equipment Dimensions HL 06-45 .....	19
5.2 Fan Units (options) .....	20
5.2.1 Fan Units Type VG .....	20
5.3 Absorption Distance BN .....	21
5.3.1 Determining the Absorption Distance .....	21
5.3.2 Absorption Distance Nomogram .....	23
5.4 Steam Manifold .....	24
5.4.1 Guidelines for Installation .....	24
5.4.2 Recommendations for dimensioning .....	25
5.5 Steam line and condensate hose layout .....	29
5.5.1 Guidelines for steam line design .....	29
5.5.2 Condensate hose layout .....	30
5.5.3 Steam line and condensate hose installation types .....	30
5.6 Chimney compartment .....	33

---

5.7 Unit Installation Check .....	33
<b>6. Water Installation .....</b>	<b>34</b>
6.1 Water Quality .....	35
6.2 Water Supply (when unit is operated with demineralized water or purified condensate) .....	36
6.3 Water Supply (when unit is operated with tap water or partially/fully softened water) ...	37
6.3.1 Steam Humidifier Feed from Holding Tank .....	39
6.4 Water Treatment .....	39
6.5 Water Discharge .....	40
6.6 Water Installation Checklist .....	41
<b>7. Electrical Installation .....</b>	<b>42</b>
7.1 Electrical Installation .....	42
7.2 Cable Connections .....	44
7.3 Safety Interlock .....	44
7.4 Wiring Diagram .....	45
7.5 Electrical Installation Checklist .....	45
<b>8. Commissioning .....</b>	<b>46</b>
<b>9. Maintenance .....</b>	<b>47</b>
9.1 Maintenance for Operation with Demineralized Water / Condensate .....	48
9.2 Maintenance for Operation with Tap Water or Partially Softened Water .....	48
9.3 Access to Control Unit .....	49
9.4 Cleaning the Coarse Strainer in the Cylinder Base .....	49
9.5 Cleaning Steam Cylinder .....	52
9.6 Cleaning connection hoses, cylinder base and nozzle .....	53
9.7 Replacing Heater Elements .....	53
9.8 Replacing Thermo Sensor (for Heater Element) .....	54
9.9 Replacing the Heater Element Sealing .....	56
9.10 Cleaning the Control Cylinder .....	56
9.11 Unlocking of a Released Thermo Sensor (for a heater element) .....	57
9.12 Unlocking of a Released Thermo Sensor (for a Solid State Relay) .....	57
9.13 Unlocking of a Released Thermo Sensor (cylinder cover) .....	57
9.14 Cleaning Blow-Down Pump .....	58
9.15 Removing Inlet Solenoid Valve and Cleaning Fine Mesh Filter .....	59
9.16 Checking Cable Screw Connections, Heater Element Wires .....	61
9.17 Operational Check .....	61
<b>10. Dismantling .....</b>	<b>62</b>
<b>11. CSA Certificate of Compliance .....</b>	<b>63</b>
<b>12. Spare Parts .....</b>	<b>65</b>
<b>13. Fax Form - Order for spare parts .....</b>	<b>70</b>
<b>14. Exploded View .....</b>	<b>71</b>
<b>15. View of Cabinet .....</b>	<b>72</b>
<b>16. Technical Specifications .....</b>	<b>73</b>

## 1. Introduction

**Dear Customer,**

Thank you for choosing a HygroMatik steam humidifier.

HygroMatik steam humidifiers represent the latest in humidification technology.

In order to operate your HygroMatik steam humidifier safely, properly and efficiently, please read these operating instructions.

Employ your steam humidifier only in sound condition and as directed. Consider potential hazards and safety issues and follow all the recommendations in these instructions.

If you have additional questions, please contact us:

**Tel.: +49-(0)4193 / 895-0 (Main Number)**

**Tel.: +49-(0)4193 / 895-293 (Technical Support Hotline)**

**Fax: +49-(0)4193 / 895-33**

**e-mail: [hotline@HygroMatik.de](mailto:hotline@HygroMatik.de)**

For all technical questions or spare parts orders, please be prepared to provide unit type and serial number (see name plate on the unit).

### 1.1 Typographic Distinctions

- preceded by a bullet: general specifications.
- » preceded by an arrow: Procedures for servicing or maintenance which should or must be performed in the indicated order.
- Installation step which must be checked off.
- italics* Terms used with graphics or drawings.

### 1.2 Documentation

#### Retention

Please retain these operating instructions in a secure, always accessible location. If the product is resold, turn the documentation over to the new operator. If the documentation is lost, please contact HygroMatik.

#### Versions in Other Languages

These operating instructions are available in several languages. If interested, please contact HygroMatik or your HygroMatik dealer.

## 1.3 Symbols in Use

### 1.3.1 Specific Symbols related to Safety Instructions

According to ANSI Z535.6 the following signal words are used within this document:

#### **▲ DANGER**

DANGER indicates a hazardous situation which, if not avoided, will result in death or serious injury.

#### **▲ WARNING**

WARNING indicates a hazardous situation which, if not avoided, could result in death or serious injury.

#### **▲ CAUTION**

CAUTION indicates a hazardous situation which, if not avoided, could result in minor or moderate injury.

#### **NOTICE**

NOTICE is used to address practices not related to physical injury.

## 1.4 Intended Use

HygroMatik steam humidifiers serve for steam production using different tap water qualities or partial softened water (all humidifier types) or fully demineralized water/cleaned condensate (heater element humidifiers only).

Proper usage also comprises the adherence to the conditions specified by HygroMatik for:

- installation
- dismantling
- reassembly
- commissioning
- operation
- maintenance
- disposal.

Only qualified and authorised personnel may operate the unit. Persons transporting or working on the unit must have read and understood the corresponding parts of the Operation and Maintenance Instructions and especially the chapter 2. „Safety Notes“. Additionally, operating personnel must be informed of any possible dangers. You should place a copy of the Operation and Maintenance Instructions at the unit's operational location (or near the unit).

**By construction, HygroMatik steam humidifiers are not qualified for exterior application.**

**▲WARNING**

**Risk of scalding!**

Steam with a temperature of up to 212 °F is produced.

Do not inhale steam directly in order to avoid respiratory damage!

---

---

## 2. Safety Instructions

These safety instructions are required by law. They promote workplace safety and accident prevention.

### 2.1 Guidelines for Safe Operation

#### 2.1.1 General

Comply with the accident prevention regulation „DGUV Regulation 3“ to prevent injury to yourself and others. Beyond that, national regulations apply without restrictions.

#### 2.1.2 Unit control

Do not perform any work which compromises the safety of the unit. Obey all safety notes and warnings present on the unit.

In case of a malfunction or electrical power supply disruption, switch off the unit immediately and prevent from restart. Repair malfunctions promptly.

#### **▲ WARNING**

##### **Restricted use**

This unit is not designed for the use by persons (also children) with limited physical, sensory and mental abilities - or without knowledge and experience - unless they are supervised or trained by a person, who is responsible for their safety. Supervise children in order to ensure that they will not play with the unit.

---

#### 2.1.3 Unit operation

#### **▲ WARNING**

##### **Risk of scalding!**

In case of leaking or defective components, hot steam may exit in an uncontrolled manner.  
Switch off unit immediately.

---

#### **NOTICE**

##### **Risk of material damage!**

The unit may be damaged if switched on repeatedly following a malfunction without prior repair.  
Rectify defects in return!

---

- The unit must not be operated on a DC power supply
- The unit may only be used connected to a steam pipe that safely transports the steam (not valid device type Mini-Steam)



- Regularly check that all safety and monitoring devices are functioning normally
- Do not remove or disable safety devices

#### **2.1.4 Mounting, maintenance, repair and dismantling of the unit**

##### **NOTICE**

The HygroMatik steam humidifier is IP20 protected. Make sure that the unit is not object to dripping water in the mounting location.

When installation is made in a room without a drain, safety precautions must be taken in order for to shut off the humidifier's water supply in event of a leak.

---

- Use genuine spare parts only
- After any repair work, have qualified personnel check the safe operation of the unit
- Attaching or installing of **additional components** is permitted only with the **written consent** of the manufacturer
- The operator is responsible for the disposal of unit components as required by law

#### **2.1.5 Electrical**

##### **⚠ WARNING**

##### **Risk of electrical shock!**

Hazardous electrical high voltage!

Any work on the electrical system must only be performed by qualified personnel.

Disconnect unit components from electrical power supply prior to work.

After electrical installation or repair work, test all safety mechanisms (such as grounding resistance).

---

##### **NOTICE**

Only use original fuses with the appropriate amperage rating.

Regularly check the unit's electrical equipment. Promptly repair any damage such as loose connections or burned wiring.

Responsibility for intrinsically safe installation of the HygroMatik steam humidifiers (steam generators) is incumbent on the installing specialist company.

---

### 3. Transport

#### 3.1 Overview

**Please note**

Proceed carefully when transporting the steam humidifier in order to prevent damage due to stress or careless loading and unloading.

#### 3.2 Transport Size and Weight

Type*	Height [cm]/ [inch]	depth [cm]/ [inch]	width [cm]/ [inch]	weight [kg]/[lb]
HL 6	93/ 36.6	42/ 16.5	74/ 29.1	39/ 86.0
HL 9	93/ 36.6	42/ 16.5	74/ 29.1	39/ 86.0
HL 12	93/ 36.6	42/ 16.5	74/ 29.1	40/ 88.2
HL 18	93/ 36.6	42/ 16.5	74/ 29.1	40/ 88.2
HL 24	93/ 36.6	42/ 16.5	74/ 29.1	42/ 92.6
HL 27	93/ 36.6	42/ 16.5	74/ 29.1	42/ 92.6
HL 30	95/ 37.4	48/ 18.9	80/ 31.5	50/ 110.2
HL 36	95/ 37.4	48/ 18.9	80/ 31.5	49/ 108.0
HL 45	95/ 37.4	48/ 18.9	80/ 31.5	50/ 110.2

\* Dimensions and weights can vary insignificantly

The heating element humidifiers type **HeaterLine 60-90** are double units - they consist of two separate units.

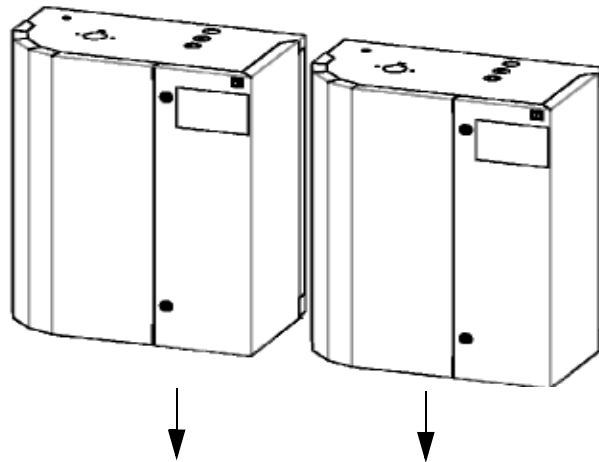

HL 60	=	HL 30	+	HL 30 (Slave)
HL 70	=	HL 36	+	HL 36 (Slave)
HL 80	=	HL 45	+	HL 36 (Slave)
HL 90	=	HL 45	+	HL 45 (Slave)

### 3.3 Packing

**Please note**

Notice the symbols affixed to the box.

### 3.4 Interim Storage

Store the unit in a dry place and protect against frost.

### 3.5 Check for Complete and Correct Delivery of Goods

Upon receipt of the unit, confirm that:

- the type and serial number on the name plate match those specified in the order and delivery documents and
- the equipment is complete and all parts are in perfect condition.

**Please note**

In case of damage during shipment or missing parts, immediately file a written claim with your carrier or supplier.

Time limits for filing freight claims with shipping companies are\*:

Transport Company	After Receipt of Goods
Carriers	no later than 4 days
Parcel Service	immediately

\* Time limits for some services subject to change.

### **3.6 Included in the Delivery**

The delivery includes:

- Unit of the selected humidifier type including selected control.
- Water installation hose.
- Manuals for the steam humidifier and the control.
- Ordered accessories (steam manifold, steam hose, condensate hose, etc.).
- Maintenance o-ring set for steam cylinder.

---

## **4. Functional description and device composition**

### **4.1 Mode of operation**

#### **The Immersion Heater Principle**

One to five heater elements (8) are placed in a closed cylinder and connected to alternating current. The cylinder (9) is filled with tap water, fully demineralized water or partially softened water. Heat generated by the heater elements increases water temperature to approx. 100°C/212°F.

When fully demineralized water is used, the feed water is practically free of minerals. This ensures long life for the cylinder and heater elements since virtually no mineral deposits can settle or build up. Fully demineralized water minimizes the number of service / maintenance checks.

When tap water is used, some of the minerals dissolved in the water will settle in the cylinder as solids of various compositions. Most of these scale deposits are removed by periodic flushing or use of a heavy-duty blow-down pump. See section "Servicing During Operation with Tap Water".

The generated steam has a temperature of about 100°C/212°F and minimal positive pressure ("pressureless" steam). It is virtually demineralized and germ-free.

### **4.2 Structure and operation of the device**

By pressing the control switch („Pos. I") the humidifier will be turned on.

When the hygrostat or controller signals a demand for humidification, the inlet solenoid valve (14) opens. Water is fed into the cylinder (9).

The water level in the cylinder must be maintained within a specified range. If the water level is too high, the elbow acts as a safety overflow for water drainage. If the water level is too low, it could cause the heater elements (8) to overheat. Therefore, power supply to the heater elements is shut off when water levels are too low.

The cylinder water level is controlled by a level control (6). The float switches indicate the water level in the steam cylinder: "Dry Run", "Humidification" and "Max. Level".

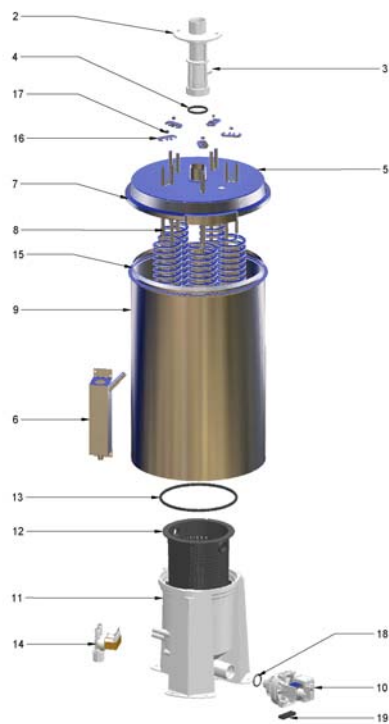

Position	Discription
2	Steam hose adapter
3	Connection control capsule
4	O-ring, steam hose adapter
5	Cover, cylinder
6	Control capsule / Water level control
7	Clamping ring
8	Electrical Heater
9	Cylinder
10	Blow-down pump
11	Base
12	strainer insert
13	O-ring, base
14	Water inlet solenoid valve
15	O-ring, base
16	Pressure plate for heater elements

For more information, also see section “Exploded View.”

The steam cylinder (9) is made of stainless steel. The cover (5) is attached to the steam cylinder using a clamping ring (7). Up to 5 heater elements (8) are mounted on the cover.

The heater elements are equipped with a mechanical high temperature safety. This mechanism provides a redundant safety system in the event of excessively low water levels (“Dry Run”).

The cylinder water is periodically flushed out with a heavy-duty blow-down pump (10). Hygromatik’s SUPER FLUSH system effectively assists this operation. During this procedure, steam production is interrupted for a few minutes.

For maintenance the cylinder can be drained by pressing the control switch „Pos.II”.

### **4.3 Internal Output Setting**

Continuous control of the HeaterLine Type steam humidifier is achieved by proportional control (pulse-width modulation) of the heater elements. In this way the humidifier can be proportionally operated across the entire output range of 5% - 100% nominal capacity.

## 5. Installation

### **⚠ WARNING**

#### **General risk of personal injury!**

Personnel not familiar with professional installation methods may sustain physical damage.

Installation of this unit to be accomplished only by qualified personnel (persons with completed training in the plumbing field and in the field of electrical installation work, respectively)!

---

### **⚠ WARNING**

#### **Risk of electrical shock!**

Hazardous electrical high voltage!

Unit must be disconnected from electrical power supply during installation.

---

### **⚠ WARNING**

#### **Risk of foot injuries!**

Unit may drop during mounting involving a single person.

Helping hand of a second person is required.

---

**Please note** HygroMatik accepts no liability for damage due to faulty installation.

**Please note** Attaching or installing additional components is permitted only with the written consent of the manufacturer, or else the warranty is void.

### 5.1 Environment Parameters to be met and Mounting Recommendations

When selecting the installation site for the steam humidifier, take the following into account:

- The minimum clearances indicated in the fitting measures section must be observed in order to ensure adequate unit ventilation and allow for unobstructed access in case of maintenance
- Protection class IP20
- By design, HygroMatik steam humidifiers are not qualified for outdoor installation (electronical components and water-bearing parts may be damaged)



- Ambient temperature must lie between +41 and +104 °F in order to protect the unit electronics against damage; frost may damage the steam cylinder
- Relative humidity must not exceed 80 % r.h., since values beyond may lead to electronic malfunction or damage
- Installation in a closed room requires aeration and, eventually, temperature conditioning in order to meet the a.m. environmental conditions
- The steam humidifier should be installed as close as possible to the steam manifold. Optimum performance is only guaranteed when steam and condensate hoses are kept short
- Make use of existing water connections for supply and draining
- Hoses must be laid at a consistent 5 to 10 % incline/decline in order to definitely prevent sagging and kinking
- Mount the unit on a stable, preferably solid wall offering the bearing capacity required (s. unit technical specifications). If such a wall is not at hand, the unit may be attached to a stand bracket firmly bolted to the floor
- Mounting the unit must be perpendicularly aligned in both the vertical and horizontal axis (plumb and level) in order to achieve uniform immersed surface areas for the electrodes
- The steam humidifier rear panel heats up during operation (to a maximum of 158 °F). Take care that the construction on which the unit is to be mounted is not made of temperature-sensitive material

## 5.1.1 Fitting Measures

### Wall Distance

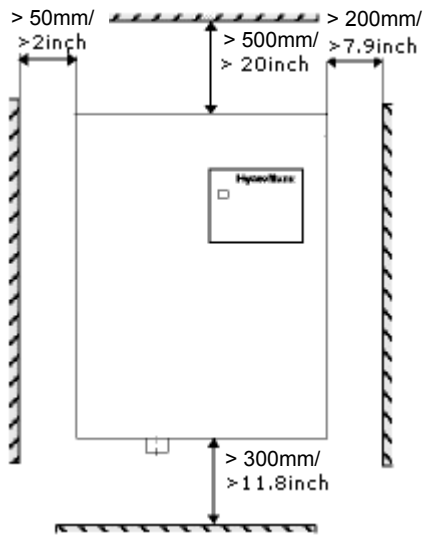

**Please note** When determining the steam humidifier positioning, make use of existing connections (supply water and drain), if possible.

### Wall Mounting

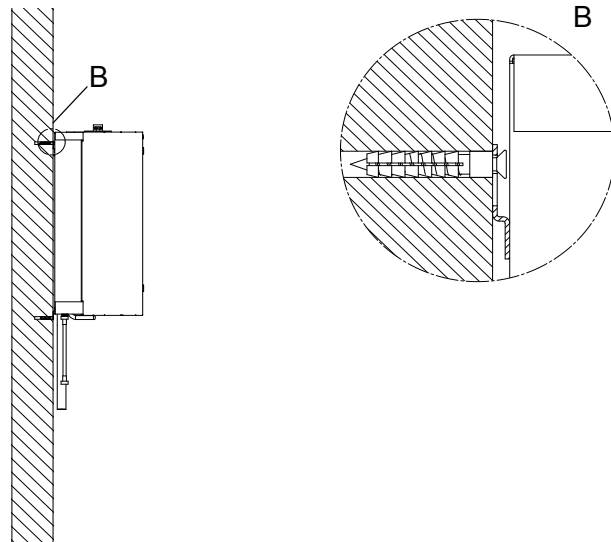

**Please note** For proper functioning of the steam generator the plumb-vertical installation is mandatory

Measures for drills for wall mounting please see table (measures d and e) in chapter „Equipment Dimensions“. If there is no suitable wall, it is recommended that the equipment is installed on brackets which can be embedded in the floor.

### 5.1.2 Equipment Dimensions HL 06-45

	HL 06-27 [mm]/ [inch]	HL 30-45 [mm]/ [inch]
a	830/ 32.7	855/ 35.0
b	645/ 25.4	688/ 27.1
c	325/ 12.8	395/ 15.6
d	591/ 23.3	634/ 25.0
e	771/ 30.4	795/ 31.3
f	38/ 1.5	38/ 1.5
g	268/ 18.6	310/ 12.2
h	51/ 2.0	51/ 2.0
i	40/ 1.6	40/ 1.6
j	167/ 6.6	197/ 7.8
k	161/ 6.3	204/ 8.0
l	76/ 3.0	76/ 3.0

View from below

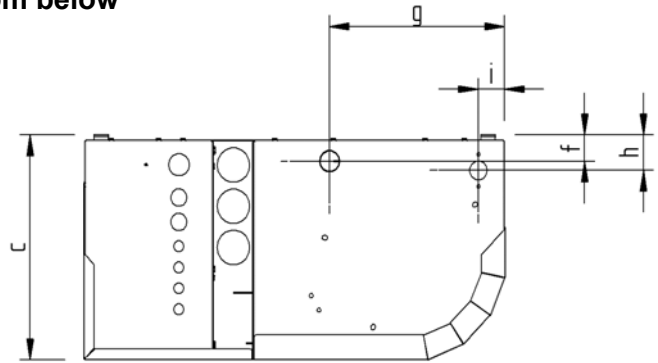

Rear view

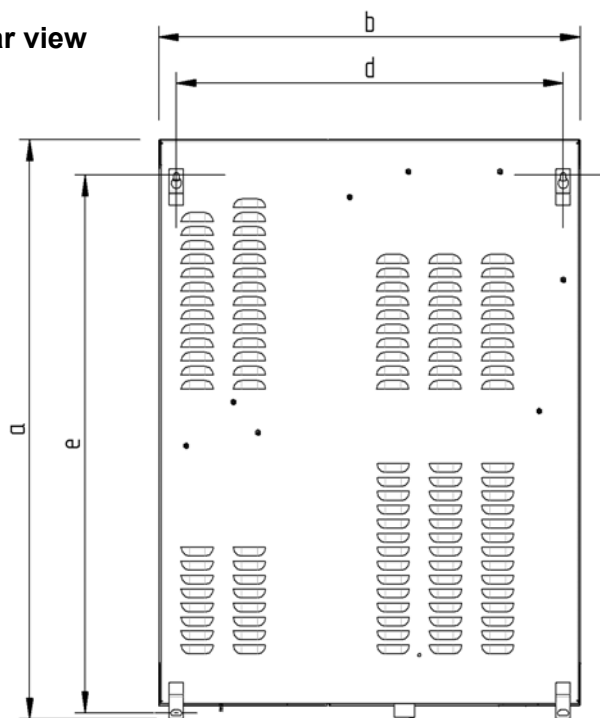

View from top

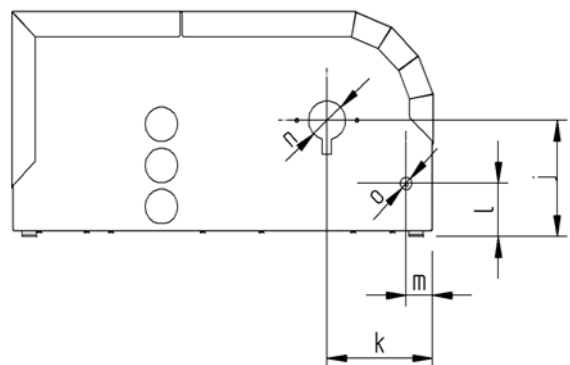

## 5.2 Fan Units (options)

**Please note**

The fan units should be positioned in a way that avoids drafts. In general, a minimum height of 6 ft 7 in (2 m) above floor is sufficient. Install the fan units directly on a wall.

**⚠ WARNING**

**Risk of skin burning or scalding!**

During operation and for at least 10 mins afterwards the steam nozzles are hot. Do not touch!

During operation hot steam discharges from the nozzles. Avoid any contact in the field of the visible steam cloud.

Due to improper installation or contamination hot water may drip from the nozzles. Do not reside in the area directly under the nozzles.

Unit Type	Fan Units
HL 6	VG 08
HL 9	VG 17
HL 18 - 30	VG 30
HL 36, 45, 60	2 x VG 30
HL 70, 80, 90	4 x VG 30

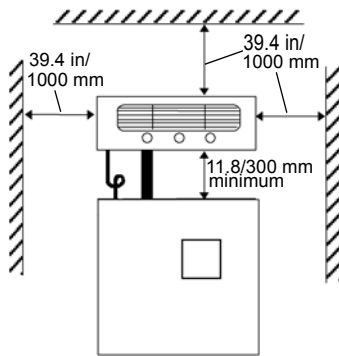

Front View Wall Installation

**⚠ WARNING**

**Rotating parts!**

During operation the cross-flow fan rotates.

Do not touch!

Do not introduce any matter through the fan grid.

### 5.2.1 Fan Units Type VG

- Install the fan units over the steam humidifier
- When employing multiple fan units, do not exceed a maximum distance of 5 m from the steam humidifier
- Observe the clearances specified in the figs.

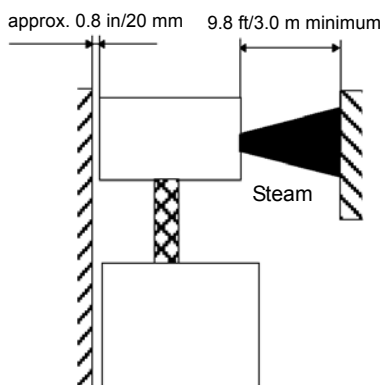

Side View Wall Installation

#### Technical specifications for fan units

Fan Unit		VG08	VG17	VG30
Quantity of Steam	[lb/h /kg/h]	17.6/8	37.5/17	66/30
Steam Inlet	[in/mmφ]	0.98/25	0.98/25	1.57/40
Condensate Outlet	[in/mmφ]	0.55/14	0.47/12	0.47/12
Nominal Output	[W]	26	35	67
Nominal voltage	[V]	230	230	230
Dimensions	W [in/mm]	17.4/441	20/507	21.7/550
	H [in/mm]	6.7/171	6.7/171	6.7/171
	D [in/mm]	7.1/180	9.3/237	11/277
Weight	[lb/kg]	7.9/3.6	13.2/6	15.4/7
Sound Level (3 ft 3.37 in/1m distance to the source of noise)	[dB(A)]	52	54	57

### 5.3 Absorption Distance $B_N$

The "absorption distance" ( $B_N$ ) is defined as the distance from the steam feed to where the steam is completely absorbed in the treated air. Within the absorption distance, steam is visible as mist in the air stream.

Condensation may occur on anything installed within the absorption distance.

Although steam outside the absorption distance ( $B_N$ ) is completely absorbed, it is not yet evenly diffused in the duct. If you plan to install any parts or devices inside the absorption distance, such as sensors or elbows, we recommend increasing the absorption distance using the formulae below. The absorption distances required for certain installed fittings are distinguished by separate symbols and calculated as a multiplier of the absorption distance  $B_N$ .

Absorption Distance	
$B_N$	for normal obstructions, such as sensors, ventilators, outlets
$B_c = (1,5...2) \times B_N$	for fine filters, heat registers
$B_s = (2,5...3) \times B_N$	for particle filters
$B_d = (3...5) \times B_N$	for humidity sensors, duct humidistats

The absorption distance has no fixed value, but depends on many factors. These are depicted in the absorption distance nomogram below.

#### 5.3.1 Determining the Absorption Distance

To determine the absorption distance, the following parameters are required:

- Air humidity before humidification  $x_1$  in g/kg.
- Air temperature after humidification  $t_2$  in °C (with steam humidifiers the change in air temperature due to humidification may be disregarded  $t_1$  or  $t_2$ ).
- Specific increase in humidity  $\Delta x$  in g/kg (can be determined in the h,x diagram)
- quantity of steam introduced  $\overset{o}{m}_D$  in kg/h.
- air speed  $w_L$  in m/s in air duct
- Total length  $l_D$  of the steam manifold installed in the air duct

Length  $l_D$  of the usable steam manifold depends on the dimensions of the air duct. The length of the absorption distance can be reduced by using multiple steam manifolds (also see section on the steam manifold).

**Method:**

Graphically determine absorption distance  $B_N$  using the absorption distance nomogram (also see Section „Absorption Distance Nomogramm“). Enter the value of the parameters enumerated above into the respective quadrants. The resulting point of intersection indicates the value of the desired absorption distance  $B_N$ .

**Notes:**

Air humidity before humidification  $x_1$ : \_\_\_\_\_ [g/kg]  
Air temperature after humidification  $t_2$ : \_\_\_\_\_ [°C]  
Specific increase in humidity  $\Delta x$ : \_\_\_\_\_ [g/kg]  
quantity of steam introduced  $m_D^o$ : \_\_\_\_\_ [kg/h]  
air speed  $w_L$ : \_\_\_\_\_ [m/s]  
Total length of the steam manifold  $l_D$ : \_\_\_\_\_ [mm]

### 5.3.2 Absorption Distance Nomogram

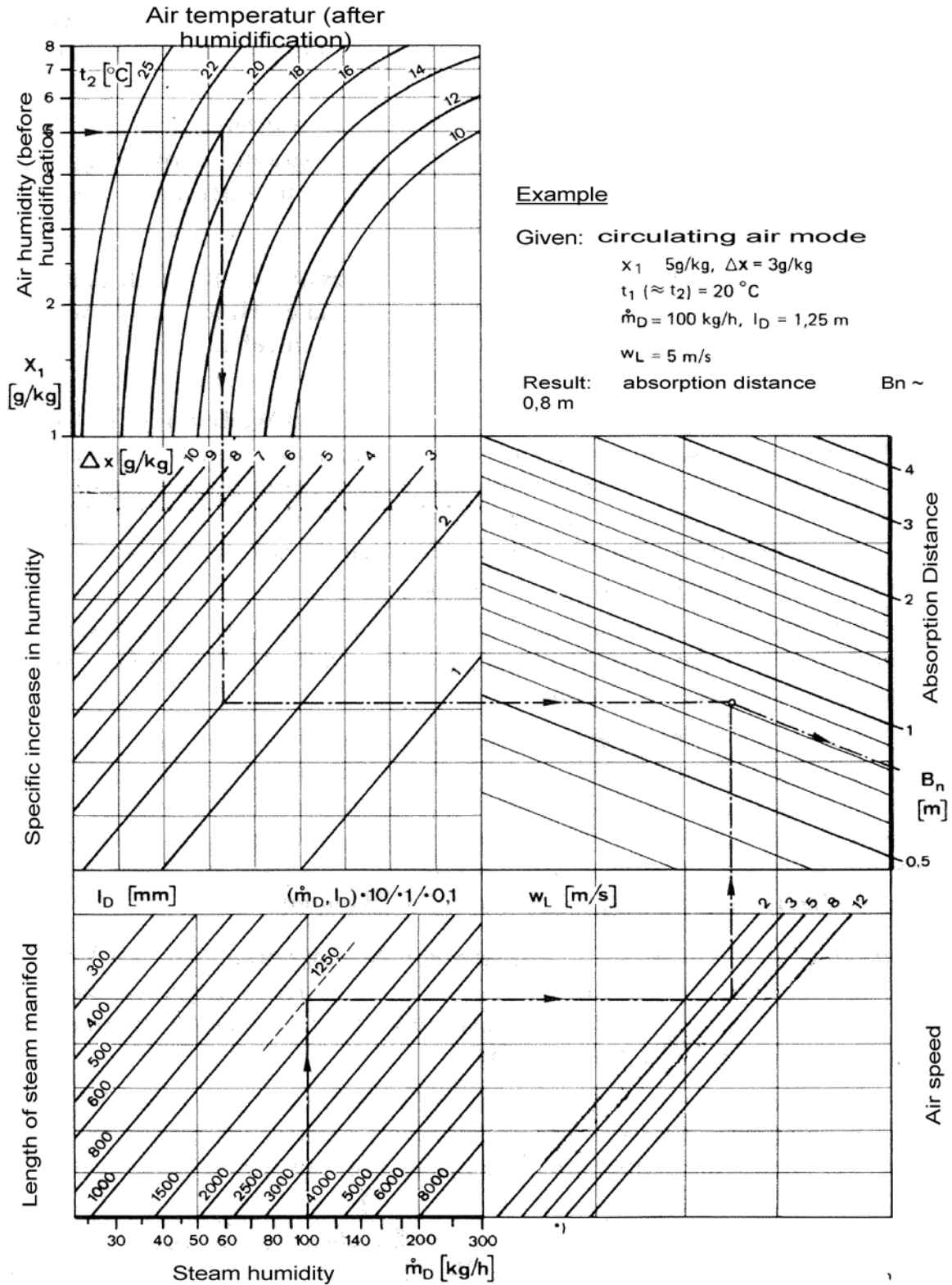

Source: Henne, Erich: Luftbefeuchtung (Air Humidification), 3<sup>rd</sup> Edition 1984 (Page 101), Oldenbourg Industrieverlag, Munich

## 5.4 Steam Manifold

### 5.4.1 Guidelines for Installation

#### Positioning within duct

- Install the steam manifold as close as possible to the steam humidifier in order to minimize steam loss through condensation
- Steam manifold placement on the supply side of the air duct is preferable
- Install steam manifold strictly horizontal in order to ensure proper condensate drain
- Shown installation and positioning dimensions are based on empiric values. Special environmental conditions may require adjustments. Pay special attention to avoid condensate generation in air duct

#### Allowable pressures

- Max. allowable pressure in air duct is 1200 Pa (Hy 05 and Hy08 1000 Pa max.)
- On suction side, max. -500 Pa is tolerable
- With high-pressure air conditioning systems, modifications of the unit's drain hose system may possibly be required depending on the overall pressure situation. These modifications must be **coordinated with your expert dealer.**

#### Water drain

- Install a water drain within the absorption distance inside the air duct

#### When increased airflow speed is encountered

- Air flow rates beyond 3m/s may lead to condensate drainage problems at the steam manifolds due to vacuum built-up. A possible remedy is twisting the steam manifold in its horizontal axis by few angular degrees. In case of problems, pls. consult your expert dealer.

#### For steam bath applications only:

#### **NOTICE**

##### **Risk of inaccurate temperature readings.**

Do not install the steam manifold near a temperature sensor.

---

#### **⚠ WARNING**

##### **Risk of scalding!**

Hot steam with a temperature of up to 212 °F exits the steam manifold.

Install the steam manifold safe from contact with people.

---



### 5.4.2 Recommendations for dimensioning

#### Horizontal installation of steam manifold

The recommendations given below are based on homogenous air flow in the duct.

#### Standard steam manifold arrangement

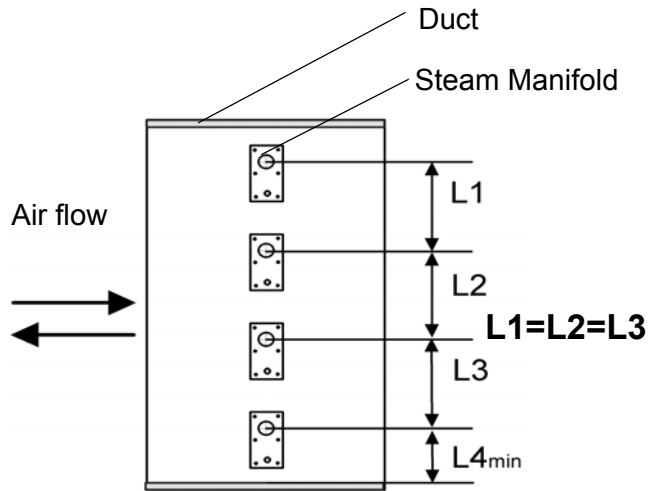

An even distribution of steam manifolds ensures a uniform steam distribution.

Please use the total height of the duct!

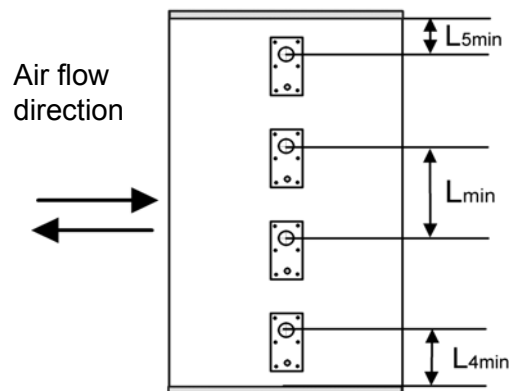

Minimum distances in order to avoid condensation:

**L<sub>min</sub> = 210mm/8.3inch:** distance „ steam manifold - next steam manifold“

**L<sub>4min</sub> = 120mm/4.7inch:** distance „lowest steam manifold - duct bottom“:

**L<sub>5min</sub> = 120mm/4.7inch:** distance „highest steam manifold - duct ceiling“

Steam manifold arrangement for special air duct shapings

Air duct	Positioning of steam manifolds	Sample														
flat	Staggered vertically and laterally															
very flat	<p>By tilting the steam manifold 30 - 45° towards the air flow direction, the minimum upper clearance can be reduced to 70mm/2.8inch.</p> <table border="1"> <thead> <tr> <th rowspan="2"></th> <th colspan="2">min. distances: H1[mm]/[inch]</th> <th rowspan="2">H2[mm]/[inch]</th> </tr> <tr> <th>30°</th> <th>45°</th> </tr> </thead> <tbody> <tr> <td>DN25/1"</td> <td>182/7.2</td> <td>168/6.6</td> <td>225/8.6</td> </tr> <tr> <td>DN40/1 1/2"</td> <td>193/7.6</td> <td>179/7.0</td> <td>230/9.1</td> </tr> </tbody> </table>		min. distances: H1[mm]/[inch]		H2[mm]/[inch]	30°	45°	DN25/1"	182/7.2	168/6.6	225/8.6	DN40/1 1/2"	193/7.6	179/7.0	230/9.1	<p>very flat duct</p>
	min. distances: H1[mm]/[inch]		H2[mm]/[inch]													
	30°	45°														
DN25/1"	182/7.2	168/6.6	225/8.6													
DN40/1 1/2"	193/7.6	179/7.0	230/9.1													
narrow, high	Identical lengths one on top of the other. Staggered laterally if possible.															
square	Identical lengths, staggered vertically and laterally															
low, very wide	facing each other															

**Vertical installation of steam manifold**

Steam manifold placement:

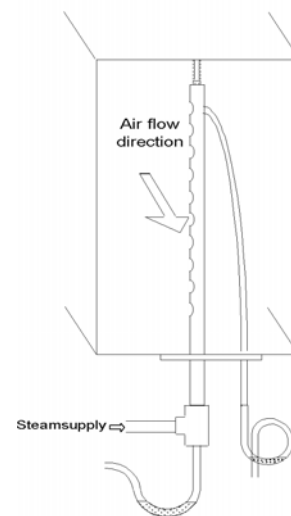

- Horizontal installation of the steam manifolds is preferred. However, installation from below into the air duct is possible.

**Length of steam manifold [mm]/[inch]\*:**

I	220/ 8.7	400/ 15.7	600/ 23.6	900/ 35.4	1200/ 47.2	1450/ 57.1
DN25/1"	x	x	x	x	x	x
DN40/1 1/2"	x	x	x	x	x	x

\* special length on request

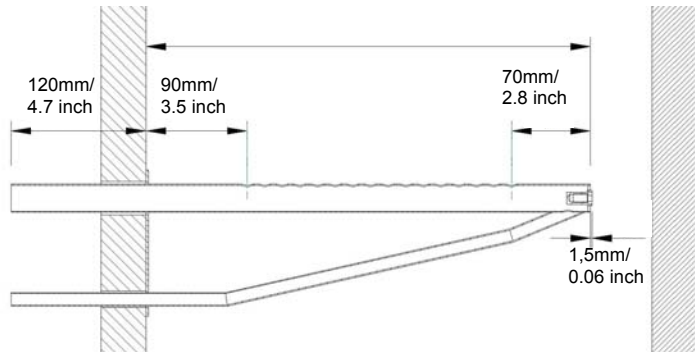

The number and size of appropriate steam manifolds, as well as the nominal width of their respective steam and condensate hoses, are found in the tables below.

**HyLine:**

Type	Steam Manifold	Steam Hose	Condensate hose
HY05-HY17	1xDN25/ 1 x 1"	DN25/ 1 x 1"	DN12/ 1 x 1/2"
HY23-HY30	1xDN40/ 1 x 1 1/2"	DN40/ 1 x 1 1/2"	DN12/ 1 x 1/2"
HY45-HY60	2xDN40/ 2 x 1 1/2"	2xDN40/ 2 x 1 1/2"	2xDN12/ 2 x 1/2"
HY90-HY116	4xDN40/ 4 x 1 1/2"	4xDN40/ 4 x 1 1/2"	4xDN12/ 4 x 1/2"

**CompactLine:**

Type	Steam Manifold	Steam Hose	Condensate Hose
C01-C17	1xDN25/ 1 x 1"	DN25/ 1 x 1"	DN12/ 1 x 1/2"
C22, C30	1xDN40/ 1 x 1 1/2"	DN40/ 1 x 1 1/2"	DN12/ 1 x 1/2"
C45	2xDN40/ 2 x 1 1/2"	DN40/ 1 x 1 1/2"	DN12/ 1 x 1/2"
C58	2xDN40/ 2 x 1 1/2"	2xDN40/ 2 x 1 1/2"	2xDN12/ 2 x 1/2"

**HeaterLine:**

Type	Steam Manifold	Steam Hose	Condensate Hose
HL 6-12 *	1xDN25/ 1 x 1"	DN25/ 1 x 1"	DN12/ 1 x 1/2"
HL 18-30	1xDN40/ 1 x 1 1/2"	DN40/ 1 x 1 1/2"	DN12/ 1 x 1/2"
HL 36-45 **	2xDN40/ 2 x 1 1/2"	2xDN40/ 2 x 1 1/2"	1xDN12/ 1 x 1/2"

\* For units HL 6 - 12 delivers one adapter DN40 / 25.

\*\* For units HL 36 - 45 HygroMatik delivers one t-connector for separating the steam on two steam manifold.

\*\*\* Special lenght on request.

## 5.5 Steam line and condensate hose layout

**Please note** Because of the high requirements on hose material under the operating conditions given, it is recommended to use genuine HygroMatik hoses only.

### 5.5.1 Guidelines for steam line design

- Steam hose nominal diameter must not be smaller than the steam outlet of the HygroMatik steam humidifier (do not restrict the cross-section, otherwise back pressure will increase)
- Steam hoses must be laid without sags and kinks and with a continuous slope of 5-10% (otherwise sags may result).
- Steam hoses should be kept as short as possible. Implement lengths beyond 5 m/16 ft as insulated fixed piping to keep energy loss and condensate generation to a minimum. Fixed piping is generally recommended for straight steam line segments
- Since the steam hose adapter is made of plastic, the steam hose fixing clamp must not be excessively tightened
- When 2 steam manifolds are to be installed (other than with a standard implementation), a Y-piece for steam distribution is required (must be ordered separately). Place the Y-piece as close as possible to the steam manifolds. Such, for the main part of the piping, just one steam hose is required resulting in minimum condensate loss
- In contrast, when installing the steam line for the Heater-Line HL36 and HL45 units, the Y-piece included in the delivery is to be installed close to the humidifier to keep the shared DN40 hose part as short as possible. The longer distance to the steam manifolds is then covered by two DN40 hoses allowing for a better steam throughput due to lower counter pressure
- Allow easy access to the steam pipe/steam hose installation
- Pressure conditions within the duct are influenced by device steam output, steam line layout and the duct composition itself. In some rare situations, it may become necessary to optimize steam line layout for achieving the results intended
- Respect minimum bending radii:  
DN 25 Steam hose:  $R_{min} = 200 \text{ mm}/8 \text{ inch}$   
DN 40 Steam hose:  $R_{min} = 400 \text{ mm}/16 \text{ inch}$

### 5.5.2 Condensate hose layout

The condensate hose may be run from the steam manifold back to the steam cylinder, as depicted in the schematic drawing below with concern to installation type 1. The condensate hose is connected to the manual drain hose (38) via a stainless steel tube (1 condensate hose) or a T-piece (2 condensate hoses). Alternatively, the condensate hose(s) may be fed directly in a wastewater pipe or a drain (s. installation type 2).

### 5.5.3 Steam line and condensate hose installation types

#### Installation type 1

**Steam manifold is positioned higher than 500 mm/20 inch above device upper edge:**

- » Run steam hose(s) to a height of 400 mm/16 inch minimum above the steam humidifier and then to the steam manifold(s) with a continuous incline of 5 to 10 %.
- » Run condensate hose(s) from steam manifold(s) with a 5 to 10 % decline and affix to the manual drain hose using stainless steel tube (1 condensate hose) or T-piece (2 condensate hoses), see section and fig. below. Alternatively, feed condensate directly into wastewater pipe or drain.
- » As a steam barrier, lay out a 200mm/8 inch min. loop (s. schematic representation below). Minimum distance from steam manifold to loop must be 500 mm/20 inch. Fill loop with water prior to steam humidifier commissioning.

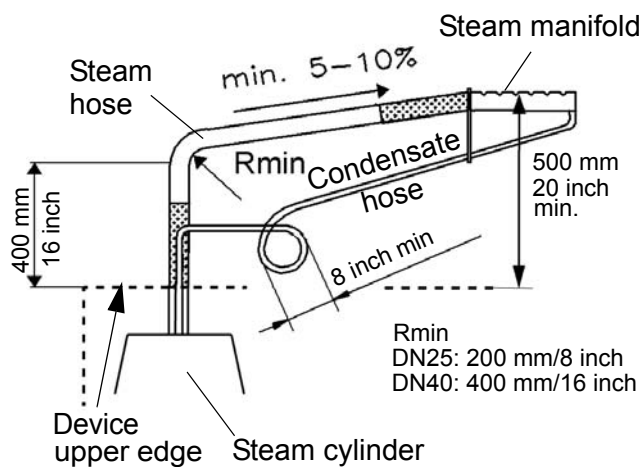

**Installation type 1,  
schematic representation**

How to connect the condensate hose(s) to the steam cylinder manual drain hose

For connecting one or two condensate hoses to the manual drain hose, HeaterLine steam humidifier delivery comprises an adapter set consisting of a stainless steel tube or a Nylon T-piece (the manual drain hose is provided to drain the steam cylinder even when the blow-down pump is not functioning).

Which adapter to use depends on the HeaterLine model in use and, consequently, the number of condensate hoses.

**Models HL6 to HL30:** 1 condensate hose -> use stainless steel tube for connection.

**Models HL36 and HL45:** 2 condensate hoses -> use Nylon T-piece for connection.

- » Remove yellow plug (20) from manual drain hose (38).
- » Run open end of manual drain hose through housing bore on top of unit.
- » Attach appropriate adapter to manual drain hose using clamp provided.
- » Attach condensate hose(s) to stainless steel tube or T-piece, respectively, using clamp(s).

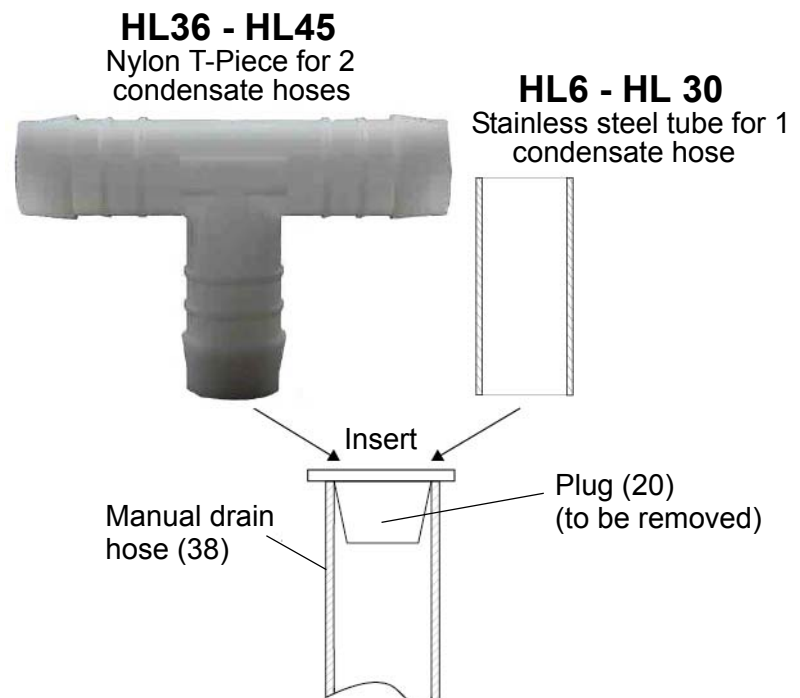

**Condensate hose connection to manual drain hose via T-piece or tube**  
(numbers in paranthesis refer to exploded view fig.)

## Installation type 2

Steam manifold is positioned less than 500 mm/20 inch above or below device upper edge:

### Please note

In this arrangement the condensate hose cannot be fed back to the steam humidifier.

- » Run steam hose to a height of 400 mm/16 inch minimum above the steam humidifier and then to the steam manifold with a continuous decline of 5 to 10 %.
- » Feed condensate hose to a wastewater pipe/drain with a 200 mm/8 inch diameter loop as a steam barrier (5 to 10 % decline is mandatory). Minimum distance from steam manifold to loop must be 500 mm/20 inch). Fill loop with water.

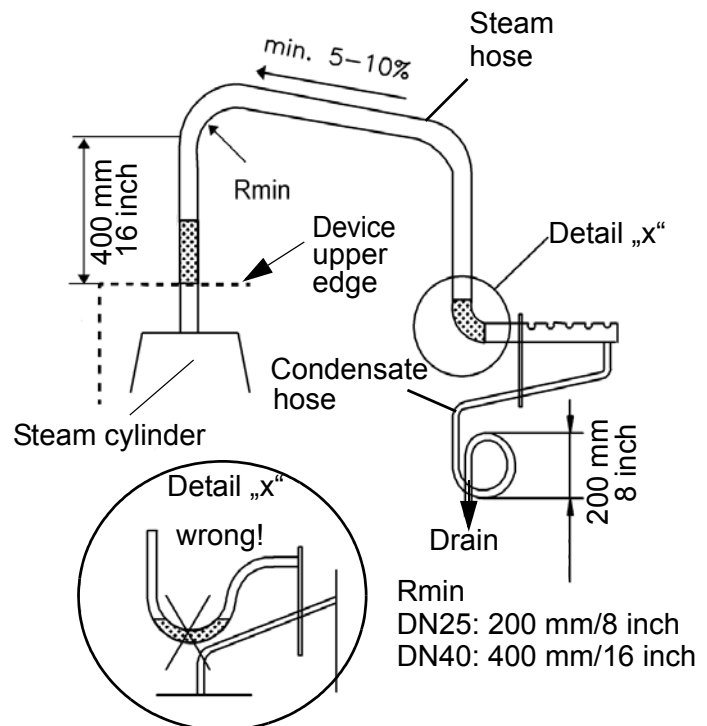

**Installation type 2,  
schematic representation**



## 5.6 Chimney compartment

Between electrical compartment (right side) and steam production compartment (left side) the chimney compartment is located. The chimney compartment is used to cool electronic components. For proper function make sure that the three holes in the top side of the housing are not covered - otherwise the heat removal is too low and a thermal cutout could be triggered.

## 5.7 Unit Installation Check

Please check the installation using the following list:

- Does unit hang vertically?
- Are wall distances to the unit within the range
- Does steam hose have a slope of 5-10%?
- Is condensate hose installed with a loop of min. 200 mm/8 inch?
- Is steam manifold positioned correctly?
- Are all bolts and clamps tightened?
- Is steam manifold installed horizontally?
- Are all sealings installed?
- Are the three holes on the top side of the housing uncovered?

## 6. Water Installation

### **⚠ WARNING**

#### **Risk of scalding!**

Very hot water on the humidifier drain side!

Have all installation work done by expert staff in order to avoid scalding hazards due to improper water guidance.

---

### **⚠ WARNING**

#### **Risk of electrical shock!**

Hazardous electrical high voltage!

Before starting installation work ensure yourself that the unit is not connected to the power supply.

---

### **⚠ CAUTION**

#### **Risk of respiratory system irritation!**

Chemical additives in treated humidification water may impair the breathing air.

Do not use any additives in treated water unless specifically recommended by the manufacturer of the water treatment unit.

---

### **NOTICE**

#### **Risk of material damage!**

Chemical additives in treated humidification water may impair the steam humidifier functioning.

Use of additives in treated water is not advisable unless specifically recommended by the manufacturer of the water treatment unit.

---

### **General Rules**

- Obey local public utility regulations
- Verify that necessary safety measures have been taken to eliminate backflow of polluted water into drinking water treatment facilities. If this is not the case, implementing of a system separator of at least the CA type (when free discharge into drainage is supported) or of the HygroMatik HyFlow system separator (retrofit option for installation by the customer) is required. For DIN EN 61770 compliance, the water intake within the humidifier features two double check valves (58)
- Supply water temperature must not exceed 40 °C/104°F. Flushed-out water must be able to drain freely

- The water supply line must have a minimum diameter of DN 12 (3/8")
- Allowable range of water pressure: 1 bar/14.5 psi min., 10 bar max./145 psi max.
- Blow-down water must drain freely

### **NOTICE**

#### **Risk of material damage!**

Copper or brass piping may corrode when flowed by demineralized water or purified condensate.

Use pipelines made from stainless steel or temperature resistant plastic.

---

### **NOTICE**

#### **Risk of material damage!**

Foreign material in water supply pipe may cause premature damage to the solenoid valve.

Flush water supply pipe before making connection to the solenoid valve (this is of particular importance in case of a newly installed pipe).

---

## **6.1 Water Quality**

The HeaterLine Type steam humidifier is designed for use with:

- tap water with a total hardness of max. 267 ppm
- demineralized water (min. conductivity 3  $\mu$ S/cm)
- fully cleaned condensate (min. conductivity 3  $\mu$ S/cm)
- partially or fully softened water

Boiling normal tap water always produces lime. Lime deposits on the surface of the heater elements may reduce their lifetime. We recommend to use a water treatment device in order to prevent scaling. In case of any questions regarding water treatment devices, please contact HygroMatik.

## 6.2 Water Supply (when unit is operated with demineralized water or purified condensate)

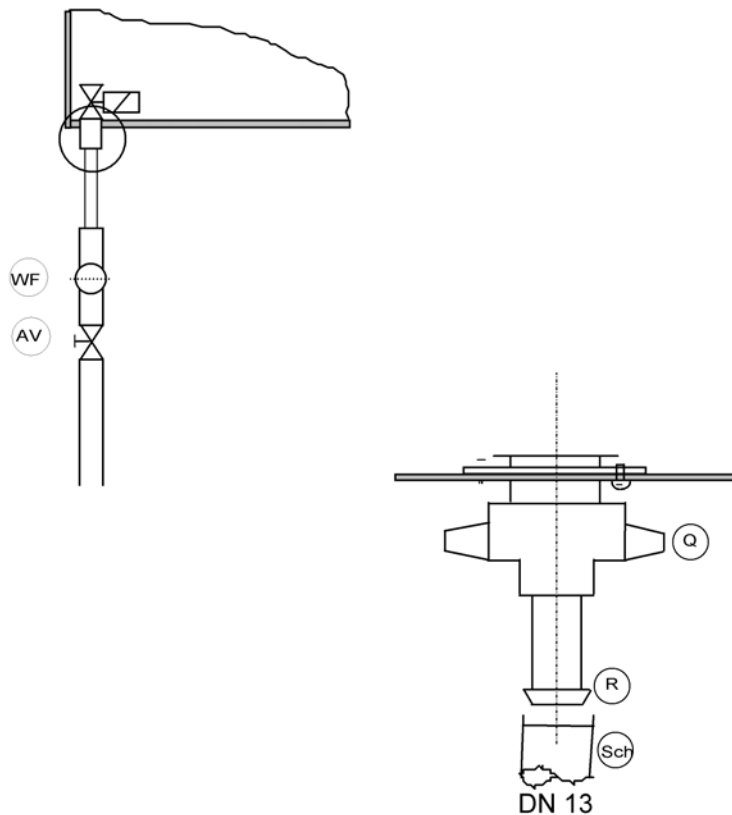

- » Install a shut-off valve (AV) in the supply line.
- » Install a water filter (WF) if necessary.
- » Make sure that a system separator is installed in the water supply line.

**Please note**

Shut-off valve (AV), water filter (WF) and system separator are not included in the standard delivery. They may be ordered separately.

Install as follows:

- » Check presence of solenoid valve fine mesh filter („K“ in solenoid valve fig., see maintenance section, chapter 9.12). Insert filter, if not yet in place.
- » Screw plastic cap nut (Q) with hose connector (R) provided in the delivery onto the supply connection protruding from the unit housing. Tighten by hand.

**NOTICE**

**Risk of material damage!**

Excessive tightening will destroy the solenoid fitting thread.  
Do not overtighten the cap nut.

- » Slide adequate 13mm inner diameter hose (SCH) over hose connector (R) and secure with a hose clamp.
- » Connect other hose end to water supply in use.

**6.3 Water Supply (when unit is operated with tap water or partially/fully softened water)**

- » Install a shut-off valve (SV) in the supply line.
- » Install a water filter (WF) if water necessary.
- » Make sure that a system separator is installed in the water supply line.

**Please note**

Shut-off valve (SV), water filter (WF) are not included in the standard delivery, but may be ordered separately from HygroMatik.

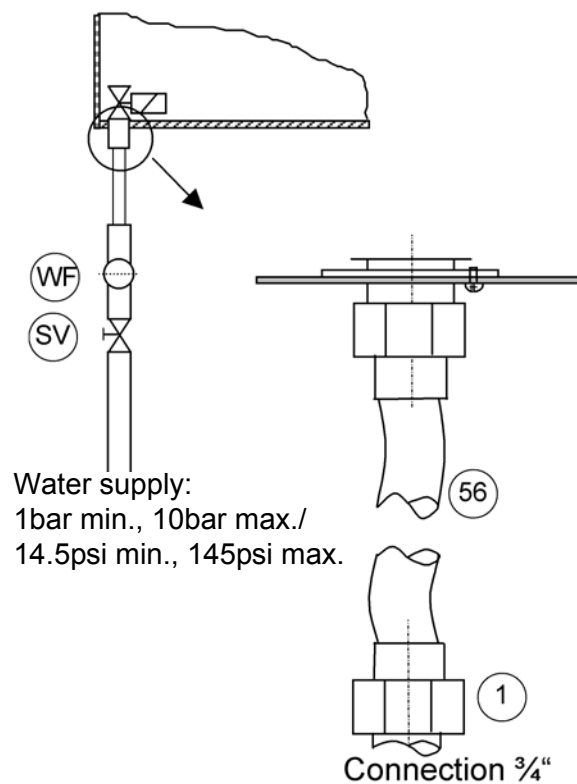

For connection to the water supply line, the water hose („56“ in „View of cabinet“ fig., chapter 15.) with cap nuts at both ends included in the delivery may be used.

Make installation as follows:

- » Check presence of solenoid valve fine mesh filter („K“ in solenoid valve fig. , see maintenance section, chapter 9.12). Insert filter, if not yet in place.
- » Screw one of the cap nuts with its inner seal ring onto the solenoid valve connection stub protruding from the humidifier housing and tighten.

**NOTICE**

**Risk of material damage!**

Excessive tightening will destroy the solenoid fitting thread.  
Do not overtighten the cap nut.

---

- » Screw the other hose end cap nut with its inner seal on a customer-provided water tap (cup nut internal thread is  $\frac{3}{4}$ “).

### 6.3.1 Steam Humidifier Feed from Holding Tank

If a holding tank is used for water supply, the „Solenoid valve 0-10 bar” option must be ordered to cope with the reduced inlet pressure. Make sure that the feed height is at least 0.5 m/20 inch. If the height is less than that, a feed pump must be inserted or the humidifier lower if possible.

**Please note**

When water supply is from a holding tank, the SUPER FLUSH function is not available.

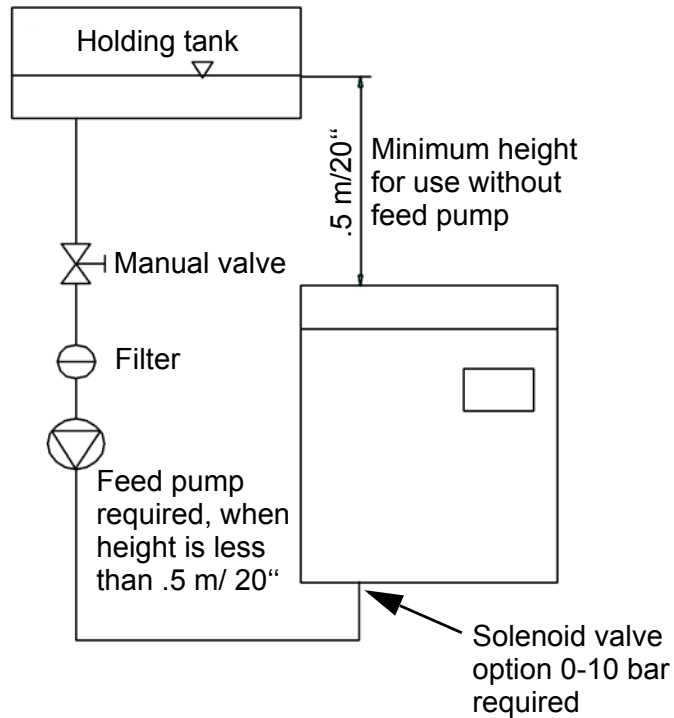

### 6.4 Water Treatment

For water treatment system sizing use the following table. The figures below assume that the humidifier is operated for 24 hours at 100% output.

HeaterLine	Max. water consumption during 24 hours [l]
6	166
9	248
12	331
18	497
24	662
30	828
36	994
45	1242

## 6.5 Water Discharge

### **▲WARNING**

#### **Risk of scalding!**

During blow down up to .3 l/sec (.08 gallon/sec) are being drained with a temperature of about 95 °C/203 °F.

Wastewater must drain freely and pressureless!

Avoid contact in order not to burn skin.

---

#### **Please note**

With the optional wastewater cooling system **HyCool**, HygroMatik offers an option for limiting the wastewater temperature of the steam humidifier. Thus by mixing in cold water during the blow-down and rinse process, it is ensured that the wastewater always has a temperature below 60°C/140°F.

#### **Please note**

Steam humidifier and wastewater discharge must be on the same pressure level.

### **Guidelines for water discharge composition**

- Use of flexible drain hose is advisable
- Do not buckle the drain hose
- For discharge line and drain pipe implementation, select temperature-resistant materials allowing up to 95°C/203°F
- Take care that ascending vapor does not condensate on humidifier cabinet

### **How to proceed**

- » Run a 1 1/4 " drain hose of 250 to 1000 mm (10 to 40 inch) length into a pressure-free outlet (DIN EN 1717 is a good design reference for adequate drain composition).
- » Slide other drain hose end over cabinet drain connection stub on the housing bottom side and secure with a clamp.



For grounding purposes, a metallic clip is attached to the cabinet drain connection stub from below (s. fig. below) making contact to the pump drain hose end (23). When water flows through the pump drain hose during blow-down, any stray current that might have built up in the drain water is grounded.

Between the pump drain hose jacket and the inner surface of the cabinet drain connection a gap exists due to the diverging diameters. If water collects on the base plate, it will flow through this gap into the drain hose and then into the drainage system.

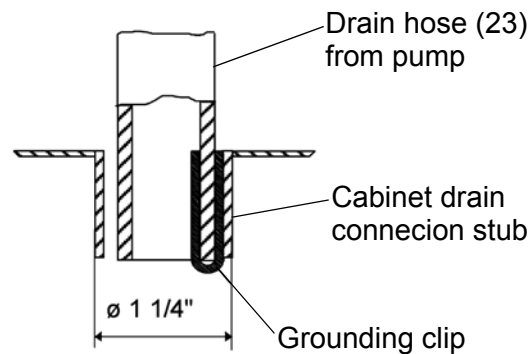

## 6.6 Water Installation Checklist

Verify correct system installation using the checklist below:

- All screws and clamps been properly tightened?
- Water supply line carefully flushed out?
- Water installation performed correctly?
- Drainage system correctly installed?
- Flushed-out water can drain freely?
- Water supply and drain free of leaks?

## 7. Electrical Installation

### **⚠ WARNING**

#### **Risk of electrical shock!**

Hazardous electrical high voltage!

All work related to electrical installation to be performed by authorized personnel only (electricians or professionals with equivalent training).

### **Please note**

The customer is responsible for checking qualifications.

**Do not connect the steam humidifier to the live power supply before all installation work has been completed!**

#### **General installation rules**

- All wiring must confirm to CEC, NEC and local electrical codes.
- Install the electrical connections according to the wiring diagram.
- Only a permanent connection to permanent wiring is allowable (UL998 CSA Std 222.2).
- Electric connector cables to be laid professionally

### **NOTICE**

#### **Take care of ESD protection!**

The electronic components of the humidifier control are very sensitive to electrostatic discharges. In order to protect these components during any type of installation, steps must be taken to guard against damage from electrostatic discharge.

### 7.1 Electrical Installation

- Class 1 wiring only
- Fuses must have a contact gap of at least 3 mm/0.12 inch per pole
- Install a separate main connection for each steam cylinder, complete with main contactor, main switch, etc.
- Connect potential equalization to the outer ground bolt
- Observe (UL998 CSA Std 222.2) when selecting wire cross-sections
- Verify that all terminals have been tightened
- Make power supply connections as shown in table below:

Type	Main Power Supply
HL6 - HL45	1 x (208V or 480V or 600V) /3Phase
HL60 - HY90	2 x (208V or 480V or 600V) /3Phase

## Fusing

We recommend employing medium blow main fuses. The tables below show input currents and the circuit protection required for the various HygroMatik humidifier models.

The steam generator should be operated with a residual current circuit breaker (RCCB).

### HeaterLine:

Model		HL06	HL09	HL12	HL18
Data at 208V/3 Phase, 60 Hz	Power Rating [kW]	3.7	X	7.4	11.0
	Input Current [A]	17.7	X	30.6	30.6
	Circuit Protection [A]	3 x 20	X	3 x 35	3 x 35
Data at 480V/3 Phase, 60 Hz	Power Rating [kW]	4.5	6.8	9.0	13.5
	Input Current [A]	9.4	14.1	16.2	16.2
	Circuit Protection [A]	3 x 10	3 x 15	3 x 20	3 x 20
Data at 600V/3 Phase, 60 Hz	Power Rating [kW]	4.5	6.8	9.0	13.5
	Input Current [A]	7.5	11.3	13.0	13.0
	Circuit Protection [A]	3 x 10	3 x 15	3 x 15	3 x 15

X=not available

Model		HL24	HL27	HL30	HL36	HL45
Data at 208V/3 Phase, 60 Hz	Power Rating [kW]	14.7	X	X	X	X
	Input Current [A]	48.0	X	X	X	X
	Circuit Protection [A]***	3 x 50	X	X	X	X
Data at 480V/3 Phase, 60 Hz	Power Rating [kW]	18.0	20.3	22.5	27.0	33.8
	Input Current [A]	25.6	24.4	32.5	38.4	47.6
	Circuit Protection [A]***	3 x 35	3 x 35	3 x 35	3 x 40	3 x 50
Data at 600V/3 Phase, 60 Hz	Power Rating [kW]	18.0	20.3	22.5	27.0	33.8
	Input Current [A]	20.5	19.5	26.0	30.7	39.0
	Circuit Protection [A]***	3 x 25	3 x 20	3 x 35	3 x 35	3 x 40

Max. current load [A] with respect to phase:

	Phase	HL06	HL09	HL12	HL18	HL24	HL27	HL30	HL36	HL45
Data at 208V/ 3 Phase, 60Hz	L1	0	X	18.0	30.5	48.0	X	X	X	X
	L2	18.0	X	30.6	30.6	30.6	X	X	X	X
	L3	18.0	X	18.0	30.5	48.0	X	X	X	X
Data at 480V/ 3 Phase, 60Hz	L1	0	0	9.4	14.1	25.7	24.4	25.6	39.6	38.5
	L2	9.4	14.1	16.3	24.5	16.3	24.4	32.5	24.5	48.0
	L3	9.4	14.1	9.4	14.1	25.7	24.4	25.6	39.6	38.5
Data at 600V/ 3 Phase, 60Hz	L1	0	0	7.5	11.3	20.5	19.5	20.5	30.8	30.8
	L2	7.5	11.3	13.0	19.5	13.0	19.5	26.0	19.5	39.0
	L3	7.5	11.3	7.5	11.3	20.5	19.5	20.5	30.8	30.8

## 7.2 Cable Connections

The table below shows the cable connections provided in HeaterLine steam humidifiers:

Unit	Connection M16	Connection M25	Connection M32
HL6 - 45	4	2	1

### Characteristics of metric cable connections

Thread	across-flats dimensions [mm] ([inch])	for cable diameter [mm] ([inch])
M16x1,5	19 (~ 0.75)	4,5 - 10 (~ 0.18 - 0.39)
M25x1,5	30 (~ 1.2)	9 - 17 (~ 0.35 - 0.67)
M32x1,5	36 (~ 1.4)	11 - 21 (~ 0.43 - 0.83)

## 7.3 Safety Interlock

**Please note** Install contact interlocks, i.e. max. hygostat, vane relay, pressure controller, air interlock etc. in series across Terminals 1 and 2.

### **NOTICE**

#### **Use max.-thermostat for protection!**

A max-hygostat should be installed in the safety interlock. The max-hygostat acts as a safety device in case the humidity sensor malfunctions.

### **NOTICE**

#### **Contacts across terminals 1 and 2 must be potential-free and properly rated!**

Rating must comply with the control voltage in use (24 VAC or 208-240 VAC, see technical data on the unit's name plate).

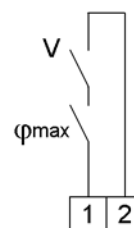

**Humidifier terminals**

## 7.4 Wiring Diagram

Please find the wiring diagram in the technical manual supplied with the control used with your humidifier. Every steam humidifier comes with a unit-specific technical manual and a manual for the control unit .

## 7.5 Electrical Installation Checklist

Perform electrical installation checks in compliance with customer site requirements and public power utility regulations:

- Does the mains voltage match the voltage on the name plate?
- Have all electrical connections been made according to the terminal diagram?
- Have all electrical cable and plug connections been properly tightened?
- Are all electrical plug connections secure?
- Is the unit grounded?

On the successful completion of all of the checks the unit is ready for switching on.

**Please note** Detailed information concerning initial operation, control, service and malfunctions as well as circuit diagrams can be found in the operation manuals for HygroMatik control units as well as on [www.hygromatik.co.uk](http://www.hygromatik.co.uk) .

## 8. Commissioning

### **⚠ WARNING**

#### **Risk of electrical shock!**

Hazardous high electrical voltage!

Start-up of the unit is restricted to expert staff only (electricians or expert personnel with equivalent training).

---

#### **Step 1: Check of mechanical integrity**

- » Check cylinder seating.
- » Check steam and condensate hose clamps.

#### **Step 2: Check of electrical wire connections**

- » Check that all electrical wire connections (including steam cylinder wiring) are tight and secure.

#### **Step 3: Switching on the steam humidifier**

- » Switch on main breaker.
- » Open water supply stopcock (operating pressure should be 1bar min., 10bar max./14.5 psi min., 145 psi max.).
- » Switch on unit by setting control switch to "1".

#### **Step 4: The unit performs a self-test**

- If the control includes a display, the message "self-test" is displayed

### **Please note**

For the next steps, control must be set in a way that permanent steam demand is requested.

#### **Step 5: Normal operation starts**

- the water solenoid valve opens and feeds water into the steam cylinder
- Initiation of steam production may take up to 20 mins
- » Let all electrically-driven operations run to completion.
- As soon as the solenoid valve begins replenishing the water periodically, the steam humidifier operates at steady nominal output and the cold start sequence is completed

#### **Step 6: Monitor unit for leaks**

- » Let unit operate for 15 to 30 minutes.
- » If leaks appear, switch off the unit.

#### **Step 7: Repair leaks**

- » Repair leaks and check again.

## 9. Maintenance

Perform regular maintenance to give your unit a long life span. Inadequate or improper maintenance may cause operational malfunctions.

### **⚠ WARNING**

#### **Risk of electrical shock!**

Unit must be switched off and protected against restart by expert staff (electricians or expert personnel with equivalent training) before any maintenance work is commenced.

---

### **NOTICE**

#### **Take care of ESD protection!**

The electronic components of the humidifier control are very sensitive to electrostatic discharges. In order to protect these components during maintenance, steps must be taken to guard against damage from electrostatic discharge.

---

The steam humidifier's performance and maintenance intervals depend primarily on the existing water quality and the quantity of steam generated. Variable water quality can lengthen or shorten the maintenance interval. Ongoing maintenance intervals can be estimated based on the amount and type of residue found in the steam cylinder. Immediate cylinder maintenance is indicated by:

- a **green, blinking LED** on the display and operating panel.
- the display reads **Service** (only with controls of Type Comfort and Comfort Plus).

## 9.1 Maintenance for Operation with Demineralized Water / Condensate

Instructions for maintenance and cleaning intervals are based exclusively on typical, empirically determined values.

Cycle	Maintenance Task
<b>4 Weeks after Initial Operation</b>	Visual check of electrical and mechanical connections. Visual check of water level control. Visual check of steam cylinder interior.
<b>Annually</b>	Visual check of electrical and mechanical connections. Visual check of water level control. Visual check of heater elements / thermo sensor. Visual inspection of interior of steam cylinder. If needed, cleaning of steam cylinder, heater elements and thermo sensor.

## 9.2 Maintenance for Operation with Tap Water or Partially Softened Water

No precise maintenance intervals can be specified because these always depend on water quality and quantity of steam generated. It is advisable to adjust the frequency of maintenance to the specific operational application.

HygroMatik recommends to open and check the steam cylinder two weeks after commissioning. Ongoing maintenance intervals can be estimated based on the amount and type of residue found in the steam cylinder.

### Blow-Down Cycles

The vaporization process causes mineral (calcium) deposits of different compositions to settle in the steam cylinder. Part of this solid build-up is removed through periodic blow-downs and fresh tap water refills with the aid of the HygroMatik SUPER FLUSH flushing system. The SUPER-FLUSH system generates a whirlpool effect in the strainer basket, intensifying removal of calcium particles during blow-down.

### Water quality

When using tap water, note that cleaning intervals shorten as the carbonate hardness level in the water increases. As a general rule, it is preferable to operate the unit with fully demineralized water. Operation will not be affected by mineral deposits and flushing losses will be minimized.

**Please note**

If desired, maintenance intervals can be lengthened by moderately increasing blow-down rates. Please consult HygroMatik.



### 9.3 Access to Control Unit

**⚠ WARNING**

**Risk of electrical shock!**

Hazardous electrical high voltage!

Make sure the unit is switched off before installing or removing the display panel.

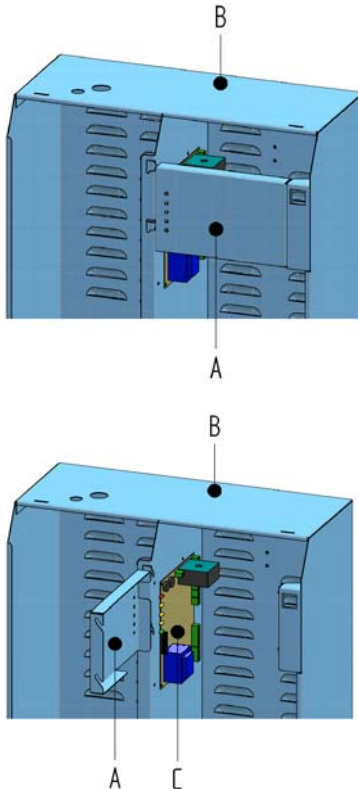

- » Remove cover (or electric compartment cover) from humidifier (B) and lift display panel (A) off guiding.
- » Turn display panel by 90 degrees (see fig. on the left) and attach display panel to the humidifier cabinet by placing the two guide pins in the two front guides.
- » The PCB (C) is now accessible.

### 9.4 Cleaning the Coarse Strainer in the Cylinder Base

**⚠ WARNING**

**Risk of skin burning!**

Hot steam cylinder during operation and for some time afterwards.

Drain steam cylinder before any maintenance work is commenced.

Switch off unit and protect against restart.

After that, wait approx. 10 mins before starting maintenance work.

Check steam cylinder temperature by cautious approximation with hand (do not touch!).

## Removal

- » Shut off water supply.
- » Drain steam cylinder by setting main switch to Pos II.
- » Disconnect power supply (set main switch to Pos 0) and secure against restart (remove main fuse and control fuse F1).
- » Make sure the device is voltage-free.
- » Disconnect steam cylinder heater element wiring connecting plug.
- » Remove star screws on the steam hose adapter.
- » Detach clip from steam hose adapter (2).
- » Push steam hose adapter upwards away from cabinet and secure with clip.
- » Open clamping belt.

## **NOTICE**

### **Risk of material damage!**

Heater element wiring may come in contact with cabinet cover support angle edges.

Take care in order not to damage the heater element cable insulation when lifting the cylinder out.

---

- » Remove cylinder base O-ring (13).
- » Lift steam cylinder (9) off cylinder base (11).
- » Remove cylinder base o-ring (13).
- » Lift strainer insert (12) out of the base using the two access holes on the side.
- » Remove all deposits from coarse strainer.
- » Clean coarse strainer mechanically (make use of wire brush)
- » Check cylinder base for deposits and remove if necessary. Pay particular attention to hose connection passes.
- » Re-insert coarse strainer taking care for proper seating. Cut-out must correspond with clip position and clip must latch.

## Assembly

- » Thoroughly clean o-ring seating in cylinder base. No calcium residue is allowed on the seating.
- » Moisten new cylinder base o-ring and insert in base.
- » Remove o-ring (4) from the steam hose adapter (2).
- » Moisten new o-ring and place on the upper part of the cylinder collar on the cylinder cover (5). If necessary, replace o-ring seal between cylinder (9) and cylinder cover.

To do so:

- » Loosen clamping ring (7) and lift off cover.
- » Remove o-ring (15).
- » Insert new o-ring, replace cylinder cover.

### **⚠ CAUTION**

#### **Risk of pinching fingers or squeezing palm skin!**

Clamping ring edges exercise significant force on cylinder cover collar and cylinder bead.

Closing lever may squeeze fingers or palm skin.

To avoid harming fingers when closing the clamping ring, make sure that your fingers are not between the clamping ring and the steam cylinder or in the closing range of the lever mechanism.

---

- » Close clamping belt.

### **NOTICE**

#### **Risk of material damage!**

Heater element wiring may come in contact with cabinet cover support angle edges.

Take care in order not to damage the heater element cable insulation when re-inserting the cylinder.

---

- » Push steam cylinder back into cylinder base with a gentle twisting motion.

### **Please note**

The “Hot surface” sticker must show towards the humidifier front.

- » With a gentle rotational movement, slide adapter (2) over the o-ring on the steam outlet and fix it with the star screws (1).
- » Insert clip between adapter and cabinet.
- » Close clamping belt.
- » Attach steam cylinder connector plug.

- » Switch breaker back on.
- » Open water supply.
- » Switch on unit and check for leaks after 15-30 minutes of operation.

If leakage occurs, switch off power supply and repair the leaks, following safety instructions for work on live components!

## 9.5 Cleaning Steam Cylinder

### Removal

- » Close off water supply.
- » Drain steam cylinder (9) by setting main switch to Pos II.
- » Disconnect power supply and secure against restart (switch off control switch, remove main fuses and control fuse F1+F2).
- » Make sure the device is voltage-free.
- » Remove steam cylinder as described in section “Cleaning Coarse Strainer in Cylinder Base.”
- » Open cylinder clamping ring (7) and lift off cover (5) with heater elements (8).

### Cleaning

#### **NOTICE**

#### **Risk of material damage!**

Excessive mechanical cleaning may damage the cylinder and/or the heater elements.

#### **Please note**

When using mineral deposit removers or cleaners to clean the cylinder and heater elements, make sure the unit is thoroughly rinsed before reassembly. Deposit removers only to be applied to the cylinder and the heater elements!

- » Remove all deposits. However, small amounts of scale deposits on the heater elements (8) are harmless.

### Assembly

- » Install cylinder (9) as described above in section “Cleaning Coarse Strainer in Cylinder Base.”

## 9.6 Cleaning connection hoses, cylinder base and nozzle

As part of periodical maintenance work, all connection hoses should be checked for good overall condition and for freedom of deposits. Also, all cylinder base (11) connections must show unobstructed passage. Clean and remove deposits, if required.

When operating the unit with partially softened water or tap water, scale can be discharged with the steam flow and may settle in the nozzle (3) sitting in the steam hose adapter. Therefore, this nozzle should be inspected regularly as part of the general maintenance review and cleaned if necessary.

## 9.7 Replacing Heater Elements

### Removal

- » Close off water supply.
- » Drain steam cylinder (9) by setting main switch to Pos. II.
- » Disconnect power supply and secure against restart (switch off control switch, remove main fuses and control fuse F1+F2).
- » Make sure the device is voltage-free.
- » Remove steam cylinder as described in section "Cleaning Coarse Strainer in Cylinder Base."
- » Open cylinder clamping ring (7) and lift off cover (5) with heater elements (8).
- » Detach connecting cable of the heater element in question from the green connection plug sitting on the cabinet separating wall. Mark the corresponding screw terminals for re-installation.
- » If applicable, remove the thermo sensor capillary tube from the heater element by detaching the retainer clips.
- » Disassemble the heater element from cylinder cover by removing the nut from the pressure plate (16) and pulling the heater element away from the cover.
- » Clean the heater element sealing area on the underside of the cylinder cover.

## Installation

- » Install new heater element, replacing the parts in the correct sequence according to the diagram, and screw nut with a torque of 5Nm onto the pressure plate.
- » Insert the heater element's connecting cable into the two marked terminals and tighten. Polarity of heater element connecting cable is not important.
- » If applicable: Re-attach thermo sensor capillary tube on heater element using retainer clips.
- » To proceed further, follow the steps described above in section "Cleaning Coarse Strainer Cylinder Base."

## 9.8 Replacing Thermo Sensor (for Heater Element)

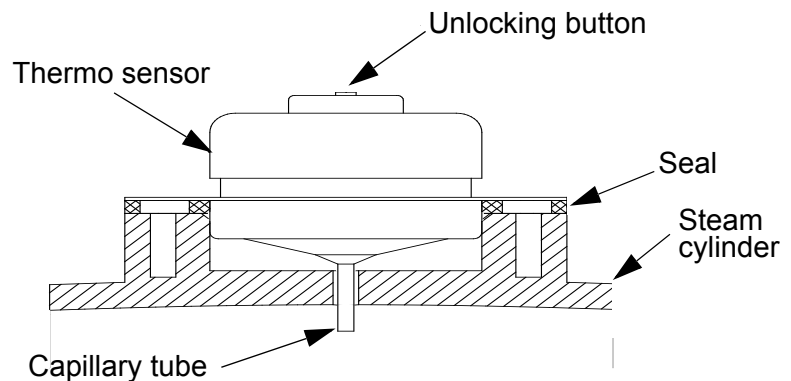

## Removal

- » Close off water supply.
- » Drain steam cylinder (9) by setting main switch to Pos. II.
- » Disconnect power supply and secure against restart (switch off control switch, remove main fuse and control fuse F1).
- » Make sure the device is voltage-free.
- » Remove steam cylinder connector plug.
- » Remove star screws from steam hose adapter (2).
- » Remove clip on steam hose adapter.
- » Push steam hose adapter upwards away from cabinet and secure with clip.
- » Loosen clamping belt.
- » Lift steam cylinder off cylinder base (11).

**NOTICE**

**Risk of material damage!**

Heater element wiring may come in contact with cabinet cover support angle edges.

Take care in order not to damage the heater element cable insulation when re-inserting the cylinder.

---

- » Remove thermo sensor cable from steam cylinder plug.
- » Detach clips holding capillary tube on heater element(s).
- » Remove the 2 screws holding thermo sensor in cylinder cover.

**NOTICE**

**Risk of material damage!**

Do not buckle the capillary tube.

---

- » Pull thermo sensor away from cylinder cover.

**Installation**

- » Insert new thermo sensor into cylinder cover bore and fasten with the 2 screws. Do not use excessive force to fasten the screws!
- » Neatly connect the capillary tube to the heater element. In case of humidifiers with two or more heating elements, the capillary tube is connected to two heating elements.
- » Reattach thermo sensor cable to the screw terminals of the steam cylinder connection plug
- » To proceed further, follow the steps described above in section "Cleaning Coarse Strainer in Cylinder Base."

## 9.9 Replacing the Heater Element Sealing

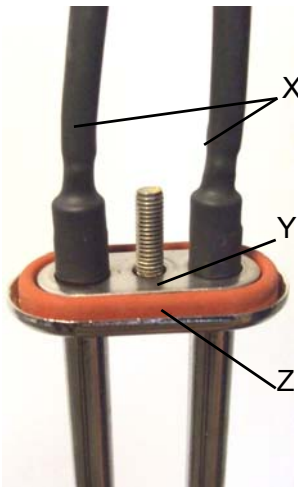

Detail: Electrical connection - heater element

- » Remove heater element as described above in section „Replacing Heater Elements/Removal“.
- » If necessary, slit shrink sleeving (X) and remove.
- » Lift retaining plate (Y) and slide over connecting wires away from heater element.
- » Remove old sealing (Z) and install a new one
- » Push retaining (Y) plate over connecting wires and mounting bolt.
- » If the shrink sleeves (X) were removed in a preceding step, install adequate shrink tubing and shrink to size with a heat gun.
- » Install heater element as described above in section „Replacing Heater Elements/Installation“.

**Please note**

Do not remove the two washers on the mounting bolt. The distance on the holding plate is set and removal of the washers may cause damage.

## 9.10 Cleaning the Control Cylinder

Whenever the steam cylinder is cleaned, the control cylinder (6) for monitoring water level should be cleaned as well.

For cleaning proceed as follows:

- » Remove steam cylinder as described in the „Cleaning Steam Cylinder“ section.
- » Loosen the four top screws that interconnect floating switch and control cylinder housing.
- » Pull out floating switch and clean carefully.
- » Take off sealing and clean.

**Please note**

The rod assembly must not be lubricated.

- » Clean the sealing surface of the control cylinder housing.

For re-installation, mount the a.m. components in reverse order.



### **9.11 Unlocking of a Released Thermo Sensor (for a heater element)**

If a thermo sensor (for a heater element) has triggered due to overtemperature, the red button is level with the top of the sensor cap. Additionally the control electronics reports the fault „Thermo sensor activated“. After the system has cooled down, the release button can be unlocked by pressing it down a few millimetres.

### **9.12 Unlocking of a Released Thermo Sensor (for a Solid State Relay)**

If a thermo sensor (for solid state relay) has triggered due to overtemperature ( $>100^{\circ}\text{C} \pm 5^{\circ}\text{K} / >212^{\circ}\text{F} \pm 41^{\circ}\text{F}$ ), the control electronics reports the fault „Thermo sensor activated“. After the system has cooled down the release pin (situated between the both plain connectors) can be released by pressing it carefully down until there is a click sound.

### **9.13 Unlocking of a Released Thermo Sensor (cylinder cover)**

If a thermo sensor (41) has triggered due to overtemperature ( $>105^{\circ}\text{C} \pm 5^{\circ}\text{K} / >221^{\circ}\text{F} \pm 41^{\circ}\text{F}$ ), the control electronics reports the fault „Thermo sensor activated“. After the system has cooled down the release pin (situated between the both plain connectors) can be released by pressing it carefully down until there is a click sound. This thermal switch is used for overall control of the radiator (principle: double check) and can only be triggered if there was a significant overheating.

If this thermal switch has tripped, the heater elements must be replaced.

## 9.14 Cleaning Blow-Down Pump

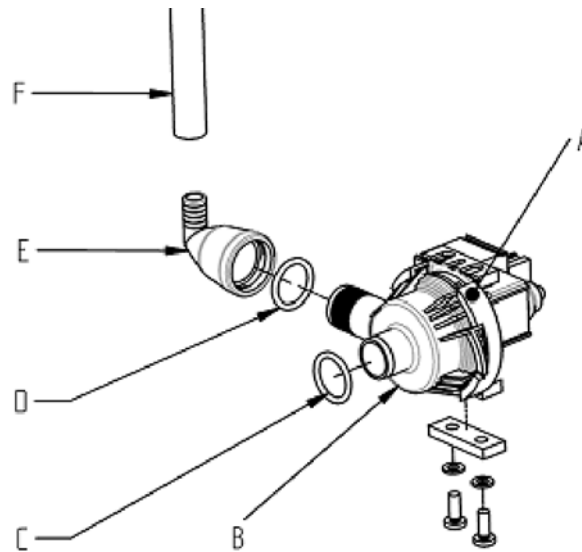

- » Close off water supply.
- » Drain steam cylinder by setting the main switch to Pos. II.
- » Disconnect power supply and secure against restart (switch off control switch, remove main fuse and control fuse F1).
- » Make sure the device is voltage-free.
- » Detach electrical connector from pump (10).
- » Detach adapter (E) from pump.
- » Remove screws (G) and pull pump away from cylinder base (11).
- » Open pump (bayonet lock).
- » Remove all residue from drain hoses and pump (if required, replace o-ring (A)).
- » Assemble pump.
- » Moisten o-ring (C) and insert in cylinder base pump seating.
- » Push pump into cylinder base pump seating and secure tightly with screws (G).
- » Moisten o-ring (D) and insert in connection stub on pump side.
- » Slide adapter (E) over connection stub on pump side.
- » Connect electrical connector to pump (polarity not specified).
- » Open water supply.

**⚠ WARNING**

**Risk of electrical shock!**

Hazardous electrical high voltage!

Follow safety instructions for work on live equipment.

---

- » Switch on unit and monitor for leakage during 15-30 minutes of operation.
- » In case of leakage switch off unit and redeem leakage(s).
- » Monitor again; repeat procedure until no more leakages are detected. Switch on unit and check for leaks after 15-30 minutes of operation.

## **9.15 Removing Inlet Solenoid Valve and Cleaning Fine Mesh Filter**

### **Removal**

- » Turn off water supply.
- » Drain steam cylinder (9) by setting main switch to Pos. II.
- » Disconnect power supply and secure against restart (switch off control switch, remove main fuse and control fuse F1).
- » Make sure the device is voltage-free.
- » Remove cylinder as described above in section "Cleaning Steam Cylinder."
- » Shut off water supply and remove cap screw from fresh water connection (L).
- » Detach connector hoses (G) from cylinder base (11) and mark position.
- » Remove electrical connectors from double solenoid valve (H) and mark position.
- » Remove solenoid valve mounting screws (I).
- » Take the solenoid valve out of hole.

### **Cleaning**

- » Remove fine mesh filter (K) from solenoid valve and clean.

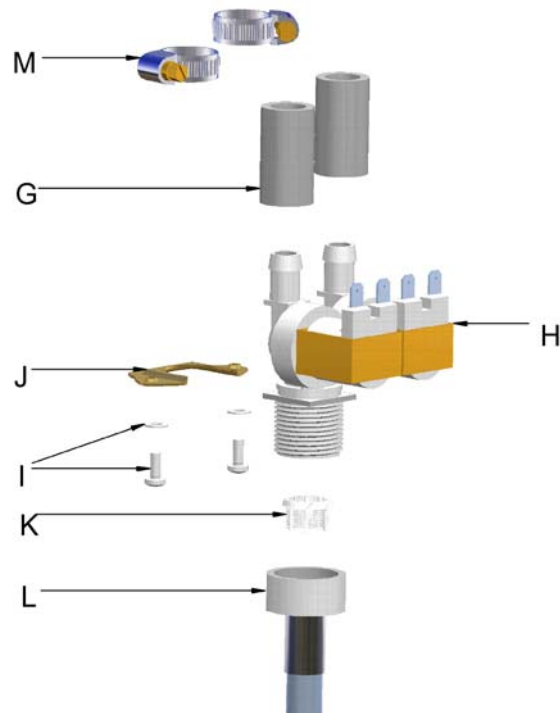

### Installation

- » Insert solenoid valve with seal in hole in unit cabinet.
- » Secure solenoid valve with screws (I).
- » Make fresh water connection (L).
- » Connect electrical cable to double solenoid valve. Take care to position correctly.
- » Attach connector hose (G) to cylinder base using clamps (M).
- » Install cylinder as described above in section “Cleaning Steam Cylinder”.
- » Open water supply.

### **⚠ WARNING**

#### **Risk of electrical shock!**

Hazardous electrical high voltage!

Follow safety instructions for work on live equipment.

- » Switch on unit and monitor for leakage during 15-30 minutes of operation.
- » In case of leakage switch off unit and redeem leakage(s).
- » Monitor again; repeat procedure until no more leakages are detected. Switch on unit and check for leaks after 15-30 minutes of operation.

## 9.16 Checking Cable Screw Connections, Heater Element Wires

### **NOTICE**

#### **Risk of material damage!**

Loose cable connections may cause excessive contact resistance and overheating of contact surfaces.

Check that all cable screw connections are securely tightened.

---

- » Check all wiring and screw terminals.
- » Ensure that heating element cable is not damaged.

## 9.17 Operational Check

- » Start up the unit and operate for a few minutes, ideally at maximum output..
- » Check safety devices.
- » Check hose connections for possible leaks.

## 10. Dismantling

Once the steam humidifier will no longer be used, dismantle (demolish or scrap) it by following the installation procedures in reverse order.

### **▲WARNING**

**Warning:** Dismantling of the unit may only be performed by qualified personnel. Electrical dismantling may only be performed by trained electricians.

---

### **Please note**

Obey the safety guidelines in section “Safety Instructions,” especially the guidelines for disposal.

## 11. CSA Certificate of Compliance



# Certificate of Compliance

**Certificate:** 2125886

**Master Contract:** 238708

**Project:** 70027120

**Date Issued:** March 23, 2015

**Issued to:** Hygromatik GmbH  
Lise-Meitner Strasse 3  
Henstedt-Ulzburg, D-24558  
GERMANY

**Attention:** Michael Lutkemann

*The products listed below are eligible to bear the CSA Mark shown with adjacent indicators 'C' and 'US' for Canada and US or with adjacent indicator 'US' for US only or without either indicator for Canada only.*



**Issued by:** Joginder  
Dhaliwal  
Joginder Dhaliwal

### PRODUCTS

CLASS - C121106 - COMFORT CONDITIONING EQUIPMENT-Humidifiers and Evaporative Coolers

CLASS - C121186 - COMFORT CONDITIONING EQUIPMENT-Humidifiers and-Evaporative Coolers - Certified to U.S. Standards

For details related to rating, size, configuration, etc. reference should be made to the CSA Certification Record or the descriptive report.

Humidifiers, heater type, stationary, industrial or commercial, rated 600V or less, 60Hz, 3 ph, as follows:

Models: HL06, HL09, HL12, HL18, HL24, HL27, HL30, HL36, HL45 with heater 48A max.

### Notes:

1. Model designation may be followed by suffix letters and numbers denoting type of control, supply voltage, number of phases.
2. Installation of the equipment in the field is subject to acceptance by the local inspection authority.

### APPLICABLE REQUIREMENTS

CSA Std C22.2 No. 104-11(4<sup>th</sup> Ed) - Humidifiers

UL Std No. 998 (5<sup>th</sup> Ed) - Humidifiers



*Supplement to Certificate of Compliance*

**Certificate:** 2125886

**Master Contract:** 238708

*The products listed, including the latest revision described below, are eligible to be marked in accordance with the referenced Certificate.*

**Product Certification History**

<b>Project</b>	<b>Date</b>	<b>Description</b>
70027120	Mar 23 2015	Update report 2125886 to add 230 VAC Control options.
70005960	May 21 2014	Update report 2125886 to add new model HL-27 and revise minor specifications of non critical components.
2387011	Jan 19 2011	Update Report 2125886 to revise component model numbers and corrections as per FIR Dt. Aug 19 2010.
2125886	May 21 2009	Steam humidifiers, 3 phase, 60Hz, Models HL06, HL09, HL12, HL18, HL24, HL30, HL36, HL45 with heater 48A max..



## 12. Spare Parts

*	HL6	HL9	HL12	HL18	HL24	HL27	HL30	HL36	HL45	Article No.	Description
											<b>Cabinet</b>
	1	1	1	1	1	1				B-2129001	Cabinet HL 6-27
							1	1	1	B-2129003	Cabinet HL 30-45
											<b>Steam Generation 208V</b>
	1									B-2205365	Cylinder compl. incl. 1 heater element 3,75 kW, 1 thermal sensor and terminal
			1							B-2205369	Cylinder compl. incl. 2 heater element 3,75 kW, 1 thermal sensor and terminal
				1						B-2205371	Cylinder compl. incl. 3 heater element 3,75 kW, 1 thermal sensor and terminal
					1					B-2205383	Cylinder compl. incl. 4 heater element 3,75 kW, 1 thermal sensor and terminal
8	1		2	3	4					B-2205091	Heater element, 208V/3,75 kW incl. gasket, plates
											<b>Steam Generation 480V</b>
	1									B-2205335	Cylinder compl. incl. 1 heater element 4,5 kW, 1 thermal sensor and terminal
		1								B-2205337	Cylinder compl. incl. 1 heater element 6,75 kW, 1 thermal sensor and terminal
			1							B-2205339	Cylinder compl. incl. 2 heater element 4,5 kW, 1 thermal sensor and terminal
				1						B-2205341	Cylinder compl. incl. 2 heater element 6,75 kW, 1 thermal sensor and terminal
					1					B-2205393	Cylinder compl. incl. 4 heater element 4,5 kW, 1 thermal sensor and terminal
							1			B-2205355	Cylinder compl. incl. 5 heater element 4,5 kW, 1 thermal sensor and terminal
								1		B-2205357	Cylinder compl. incl. 4 heater element 6,75 kW, 1 thermal sensor and terminal
									1	B-2205359	Cylinder compl. incl. 5 heater element 6,75 kW, 1 thermal sensor and terminal
8	1		2		4		5			B-2205087	Heater element, 480V/4,5 kW incl. gasket, plates
8		1		2		3		4	5	B-2205089	Heater element, 480V/6,75 kW incl. gasket, plates
											<b>Steam Generation 600V</b>
	1									B-2205xxx	Cylinder compl. incl. 1 heater element 4,5 kW, 1 thermal sensor and terminal
		1								B-2205xxx	Cylinder compl. incl. 1 heater element 6,75 kW, 1 thermal sensor and terminal
			1							B-2205xxx	Cylinder compl. incl. 2 heater element 4,5 kW, 1 thermal sensor and terminal
				1						B-2205xxx	Cylinder compl. incl. 2 heater element 6,75 kW, 1 thermal sensor and terminal
					1					B-2205xxx	Cylinder compl. incl. 4 heater element 4,5 kW, 1 thermal sensor and terminal
										B-2205xxx	Cylinder compl. with 4 heater elements 6,75kW, 1 thermal sensor and terminal
							1			B-2205xxx	Cylinder compl. incl. 5 heater element 4,5 kW, 1 thermal sensor and terminal
								1		B-2205xxx	Cylinder compl. incl. 4 heater element 6,75 kW, 1 thermal sensor and terminal
									1	B-2205xxx	Cylinder compl. incl. 5 heater element 6,75 kW, 1 thermal sensor and terminal
8	1		2		4		5			B-2205077	Heater element, 600V/4,5 kW incl. gasket, plates
8		1		2		3		4	5	B-2205079	Heater element, 600V/6,75 kW incl. gasket, plates

*	HL6	HL9	HL12	HL18	HL24	HL27	HL30	HL36	HL45	Article No.	Description
5	1	1								E-2205070	Cover for cylinder, small, for 1 heater element and 1 thermal sensor
5			1	1						E-2205072	Cover for cylinder, small, for 2 heater element and 1 thermal sensor
5						1				E-2205064	Cover for cylinder, small for 3 heater element and 1 thermal sensor
5					1					E-2205074	Cover for cylinder, small, for 4 heater element and 1 thermal sensor
5								1		E-2205066	Cover for cylinder, big, for 4 heater element and 1 thermal sensor
5							1		1	E-2205068	Cover for cylinder, big, for 5 heater element and 1 thermal sensor
9	1	1	1	1	1	1				E-2205078	Cylinder- lower part, small
9							1	1	1	E-2205076	Cylinder- lower part, big
	1	1	1	1	1	1				E-2205104	Belt for HL cylinder fixation, short
							1	1	1	E-2205106	Belt for HL cylinder fixation, long
15	1	1	1	1	1	1				E-2205086	O-ring, cylinder lower part - cylinder cover, small
15							1	1	1	E-2205084	O-ring, cylinder lower part - cylinder cover, big
	1	1	2	2	4	3	5	4	5	E-2205062	Pressu replate for heater element attachment
	1	1	1	1		1				E-2525504	Terminal 6 pole, 16mm <sup>2</sup>
					1		1	1	1	E-2525500	Terminal 9 pole, 16mm <sup>2</sup>
29	1	1	1	1	1		1	1	1	B-2205033	Thermal sensor incl. Sealing 1100mm
41	1	1	1	1	1		1	1	1	E-2205126	Thermal sensor (cylinder cover) 105°C since 01/2013
	4	4	8	8	8	8	8	8	8	E-2205012	Clamp for thermal sensor
2	1	1	1	1	1	1	1	1	1	B-2205025	Steam hose adapter DN40
3	1	1	1	1	1	1	1	1	1	B-2304067	Nozzle for steam hose adapter
	1	1	1	1	1	1	1	1	1	E-2209002	Clip for steam hose adapter DN40
4	1	1	1	1	1	1	1	1	1	E-2204022	O-ring for steam hose adapter DN40
	2	2	2	2	2	2	2	2	2	E-2205088	Star knob screw, fixation steam hose adapter HL

*	HL6	HL9	HL12	HL18	HL24	HL27	HL30	HL36	HL45	with control voltage 24V	with control voltage 208 240V	Article No.	Description
													<b>Water Feed HL</b>
14	1	1	1	1	1	1				x		B-2304045	Double solenoid valve, 0.2-10 bar, 24VAC, 2.5 l/min
14							1	1	1	x		B-2304047	Double solenoid valve, 0.2-10 bar, 24VAC, 3.5 l/min
14	1	1	1	1	1	1					x	B-2304305	Double solenoid valve SuperFlush HY05/08, HL06-27 2,5l/min at 4bar, 200-240V
14							1	1	1		x	B-2304307	Double solenoid valve SuperFlush HY13-116, HL30-45 3,5l/min at 4bar, 200-240V
	1	1	1	1	1	1					x	B-2304405	Double solenoid valve, HyCool, 2,5 l/min & 8l/min at 4bar, 200-240V,
							1	1	1		x	B-2304407	Double solenoid valve, HyCool, 3,5 l/min & 8l/min at 4bar, 200-240V,
	1	1	1	1	1	1	1	1	1	x	x	E-2304024	Fine filter in solenoid valve
	1	1	1	1	1	1	1	1	1	x	x	E-2304103	Captive coupling ring for solenoid valve 3/4"
	1	1	1	1	1	1	1	1	1	x	x	E-2304107	Gasket for inlet screwed fitting, solenoid
	1	1	1	1	1	1	1	1	1	x	x	E-8501034	Hose collar for inlet srewed fitting, 3/4", solenoid
56	1	1	1	1	1	1	1	2	2	x	x	B-2304031	Hose for water connection, 3/4" cap nuts on both sides, seal included
	1	1	1	1	1	1	1	1	1	x	x	E-2304036	Rubber seal solenoid valve - cabinet
	1	1	1	1	1	1	1	1	1	x	x	B-2304040	Mounting set for solenoid valve
	0,3	0,3	0,3	0,3	0,3	0,3	0,3	0,3	0,3	x	x	E-2604002	Hose, solenoid valve - cabinet (2 pcs. required)
	1	1	1	1	1	1	1	1	1	x	x	E-2604044	Buckling protection for hose, solenoid valve - cylinder base
6	1	1	1	1	1	1	1	1	1	x	x	B-2504129	Control cylinder for water level, compl. with flow switch (for unit before April 2007)
6	1	1	1	1	1		1	1	1	x	x	B-2504139	Control cylinder for water level, compl. with flow switch (for unit since April 2007)
6	1	1	1	1	1	1	1	1	1	x	x	E-2504174	Control cylinder for water level, without flow switch
	1	1	1	1	1	1	1	1	1	x	x	B-2504145	Flow switch, with sealings
	1	1	1	1	1	1	1	1	1	x	x	E-2304038	Rubber seal for water level control
	0,3	0,3	0,3	0,3	0,3	0,3	0,3	0,3	0,3	x	x	E-2604002	Hose, cylinder base - control cylinder
	0,3	0,3	0,3	0,3	0,3	0,3	0,3	0,3	0,3	x	x	E-2604002	Hose, control cylinder - steam hose adapter
	1	1	1	1	1	1	1	1	1	x	x	E-2604002	Hose for manual drain
	1	1	1	1	1	1	1	1	1	x	x	E-2604021	T-piece, condensate manifold, type TS12, DN12
	1	1	1	1	1	1	1	1	1	x	x	E-2204035	Condensate plug DN12
													<b>Water Drain HL</b>
11	1	1	1	1	1	1	1	1	1	x	x	E-2205050	Cylinder base
12	1	1	1	1	1	1	1	1	1	x	x	E-2205052	Strainer basket
13	1	1	1	1	1	1	1	1	1	x	x	E-2205048	O-ring, cylinder base - steam cylinder
10	1	1	1	1	1	1	1	1	1	x		B-2404025	Drain pump 24V/60Hz without mounting set
10	1	1	1	1	1	1	1	1	1		x	B-2404027	Drain pump 230V/50-60Hz without mounting set
19	1	1	1	1	1	1	1	1	1	x	x	B-2424014	Mounting set for drain pump
	1	1	1	1	1	1	1	1	1	x	x	E-2404008	Drain pump housing
18	2	2	2	2	2	1	2	2	2	x	x	E-3220005	O-ring, cylinder base - drain pump
	1	1	1	1	1	1	1	1	1	x	x	E-2425002	Adapter, pump - drain hose, straight model, connections DN25/13
	1	1	1	1	1	1	1	1	1	x	x	E-3220005	O-ring for drain pump
	1	1	1	1	1	1	1	1	1	x	x	E-2425004	Elbow with vent pipe
	0,8	0,8	0,8	0,8	0,8	0,8	0,9	0,9	0,9	x	x	E-2604002	Hose, drain pump - elbow
	0,8	0,8	0,8	0,8	0,8	0,8	0,9	0,9	0,9	x	x	E-2604004	Drain hose, elbow - outlet

*	HL6	HL9	HL12	HL18	HL24	HL27	HL30	HL36	HL45	with control voltage 24V	with control voltage 208 240V	Article No.	Description
<b>Control 208V</b>													
	1	X				X	X	X	X	x		B-2507043	main contactor 20A, DILM7, Spulenspg. 24VAC
		X	1	1		X	X	X	X	x		B-2507063	main contactor 35A, DILM17, Spulenspg. 24VAC
		X			1	X	X	X	X	x		B-2507073	main contactor 50A, DILM40, Spulenspg. 24VAC
	1	X					X	X	X		x	B-2507041	Main contactor 20A, DILM17, Coil voltage 230VAC
		X	1	1			X	X	X		x	B-2507061	Main contactor 35A, DILM17, Coil voltage 230VAC
		X			1		X	X	X		x	B-2507071	Main contactor 50A, DILM40, Coil voltage. 230VAC
	1	X				X	X	X	X	x	x	B-2602001	Solid state relay 25 A, 1ph., heat sink (150 x 50) mm,
		X	1			X	X	X	X	x	x	B-2602005	Solid state relay 50 A, 2ph., heat sink (150 x 80) mm
		X		2		X	X	X	X	x	x	B-2602007	Solid state relay 75 A, 1ph., heat sink (150 x 50) mm
		X			2	X	X	X	X	x	x	B-2602009	Solid state relay 75 A, 1ph., heat sink (150 x 80) mm
<b>Control 480V</b>													
	1	1	1							x		B-2507043	main contactor 20A, DILM7, Spulenspg. 24VAC
				1	1	1	1			x		B-2507063	main contactor 35A, DILM17, Spulenspg. 24VAC
								1	1	x		B-2507073	main contactor 50A, DILM40, Spulenspg. 24VAC
	1	1	1	1							x	B-2507041	Main contactor 20A, DILM17, Coil voltage 230VAC
						1					x	B-2507061	Main contactor 35A, DILM17, Coil voltage 230VAC
					1		1				x	B-2507071	Main contactor 50A, DILM40, Coil voltage. 230VAC
								1	1		x	B-2507081	Main contactor 65A, DILM50, Coil voltage. 230VAC
	1	1								x	x	B-2602001	Solid state relay 25 A, 1ph., heat sink (150 x 50) mm,
			1	1						x	x	B-2602003	Solid state relay 50 A, 2ph., heat sink (150 x 50) mm
					1					x	x	B-2602005	Solid state relay 50 A, 2ph., heat sink (150 x 80) mm
						2	2			x	x	B-2602007	Solid state relay 75 A, 1ph., heat sink (150 x 50) mm
								2	2	x	x	B-2602009	Solid state relay 75 A, 1ph., heat sink (150 x 80) mm
<b>Control 600V</b>													
	1	1	1	1						x		B-2507043	main contactor 20A, DILM7, Spulenspg. 24VAC
					1	1	1	1		x		B-2507063	main contactor 35A, DILM17, Spulenspg. 24VAC
									1	x		B-2507073	main contactor 50A, DILM40, Spulenspg. 24VAC
	1	1	1	1	1						x	B-2507041	Main contactor 20A, DILM17, Coil voltage 230VAC
						1	1	1	1		x	B-2507061	Main contactor 35A, DILM17, Coil voltage 230VAC
	1	1								x	x	B-2602001	Solid state relay 25 A, 1ph., heat sink (150 x 50) mm,
			1	1						x	x	B-2602003	Solid state relay 50 A, 2ph., heat sink (150 x 50) mm
					1	1				x	x	B-2602005	Solid state relay 50 A, 2ph., heat sink (150 x 80) mm
						2	2	2		x	x	B-2602007	Solid state relay 75 A, 1ph., heat sink (150 x 50) mm
	1	1	1	1		1				x	x	E-2525506	Terminal 6 pole, 6mm <sup>2</sup> (mounted)
					1		1	1	1	x	x	E-2525502	Terminal 9pole, 6mm <sup>2</sup> (mounted)
<b>Basic</b>													
	1	1	1	1	1	1	1	1	1	x		B-2526209	Electronic pcb Basis for HL
	1	1	1	1	1	1	1	1	1		x	B-2526203	Electronic pcb Basis for HL
							1	1	1	x		B-2526209	Elektronik pcb Basis for slave units
							1	1	1		x	B-2526203	Elektronik pcb Basis for slave units
	(1)	(1)	(1)	(1)	(1)	(1)	(1)	(1)	(1)	x		B-2526219	Electronic pcb Basis for HL steam bath

*	HL6	HL9	HL12	HL18	HL24	HL27	HL30	HL36	HL45	with control voltage 24V	with control voltage 208/240V	Article No.	Description
													<b>Comfort</b>
	1	1	1	1	1	1	1	1	1	x		B-2526209	Electronic pcb Basis for HL
	1	1	1	1	1	1	1	1	1		x	B-2526203	Electronic pcb Basis for HL
							1	1	1	x		B-2526209	Elektronik pcb Basis for slave units
							1	1	1		x	B-2526203	Elektronik pcb Basis for slave units
	(1)	(1)	(1)	(1)	(1)	(1)	(1)	(1)	(1)	x		B-2526219	Electronic pcb Basis for HL steambath
	(1)	(1)	(1)	(1)	(1)	(1)	(1)	(1)	(1)		x	B-2526213	Electronic pcb Basis for HL steambath
	(1)	(1)	(1)	(1)	(1)	(1)	(1)	(1)	(1)	x	x	B-2526401	Comfort display incl. mounting plate with foil
	(1)	(1)	(1)	(1)	(1)	(1)	(1)	(1)	(1)	x	x	B-2526445	Comfort DS display incl. mounting plate with foil
	(1)	(1)	(1)	(1)	(1)	(1)	(1)	(1)	(1)	x	x	B-2120903	mounting plate with foil for Comfort unit with display
	(1)	(1)	(1)	(1)	(1)	(1)	(1)	(1)	(1)	x	x	B-2120911	mounting plate with foil for Comfort DS unit with display
	(1)	(1)	(1)	(1)	(1)	(1)	(1)	(1)	(1)	x	x	E-2525412	Foil for mounting plate type Comfort
													<b>Comfort Plus</b>
	1	1	1	1	1	1	1	1	1	x		B-2526209	Electronic pcb Basis for HL
	1	1	1	1	1	1	1	1	1		x	B-2526203	Electronic pcb Basis for HL
							1	1	1	x		B-2526209	Elektronik pcb Basis for slave units
							1	1	1		x	B-2526203	Elektronik pcb Basis for slave units
	(1)	(1)	(1)	(1)	(1)	(1)	(1)	(1)	(1)	x		B-2526219	Electronic pcb Basis for HL steambath
	(1)	(1)	(1)	(1)	(1)	(1)	(1)	(1)	(1)		x	B-2526213	Electronic pcb Basis for HL steambath
	(1)	(1)	(1)	(1)	(1)	(1)	(1)	(1)	(1)	x	x	B-2526403	Comfort Plus display incl. mounting plate with foil
	(1)	(1)	(1)	(1)	(1)	(1)	(1)	(1)	(1)	x	x	B-2526447	Comfort Plus DS display incl. mounting plate with foil
	(1)	(1)	(1)	(1)	(1)	(1)	(1)	(1)	(1)	x	x	B-2120905	Mounting plate with foil for Comfort Plus with display
	(1)	(1)	(1)	(1)	(1)	(1)	(1)	(1)	(1)	x	x	B-2120913	Mounting plate with foil for Comfort Plus DS with display
	(1)	(1)	(1)	(1)	(1)	(1)	(1)	(1)	(1)	x	x	E-2525414	Foil for mounting plate Comfort Plus
													<b>Accessories</b>
	1	1	1	1	1	1				x	x	B-3216091	O-ringset for HL 6 - 24
							1	1	1	x	x	B-3216093	O-ringset for HL 30 - 45
										x	x	B-3216085	Heater maintenance set (incl. sealing, pressureplate, nut, washers)
										x	x	E-2604034	Reducing piece DN 40/DN 25 for steam hose
										x	x	E-2604012	Steam hose DN 25, per m
										x	x	E-2604013	Steam hose DN 40, per m
										x	x	E-2604002	Condensate hose DN 12, per m
										x	x	E-2604004	hose, vent - outlet (14,2 x 3 mm)
										x	x	E-2404004	Steam hose clamp DN 25
										x	x	E-2604016	Steam hose clamp DN 40
										x	x	E-2304015	Condensate hose clamp DN 12
										x	x	E-2604042	Steam manifold T-piece DN 25, stainless steel
										x	x	E-2604023	Steam manifold T-piece DN 40, stainless steel
										x	x	E-2604021	Condensate connector T-piece DN 12
										x	x	E-2604029	Hose nozzle DN 25 - R 3/4"
										x	x	E-2504031	Driller (17-21mm)

If you order any spare parts, specify type and serial number of the unit, please.

\* see exploded view

### 13. Fax Form - Order for spare parts

HygroMatik GmbH  
Lise-Meitner-Str. 3  
24558 Henstedt-Ulzburg  
Tel. +4904193/895-0

**Fax Form**

Please copy, fill in and fax to

Fax.No. **+49(0)4193/895-31**

## Order of spare parts

unit type \* \_\_\_\_\_ serial no.\* \_\_\_\_\_

commission: \_\_\_\_\_ order no.: \_\_\_\_\_

quantity	article	article no.

date of delivery \_\_\_\_\_ forwarder \_\_\_\_\_ shipment by \_\_\_\_\_

delivery address (if different  
from invoice address)

\_\_\_\_\_

\_\_\_\_\_

\_\_\_\_\_

\_\_\_\_\_

company stamp (delivery adress)

date/signature

\* Order can only be processed if unit type and unit serial no. are filled in.

## 14. Exploded View

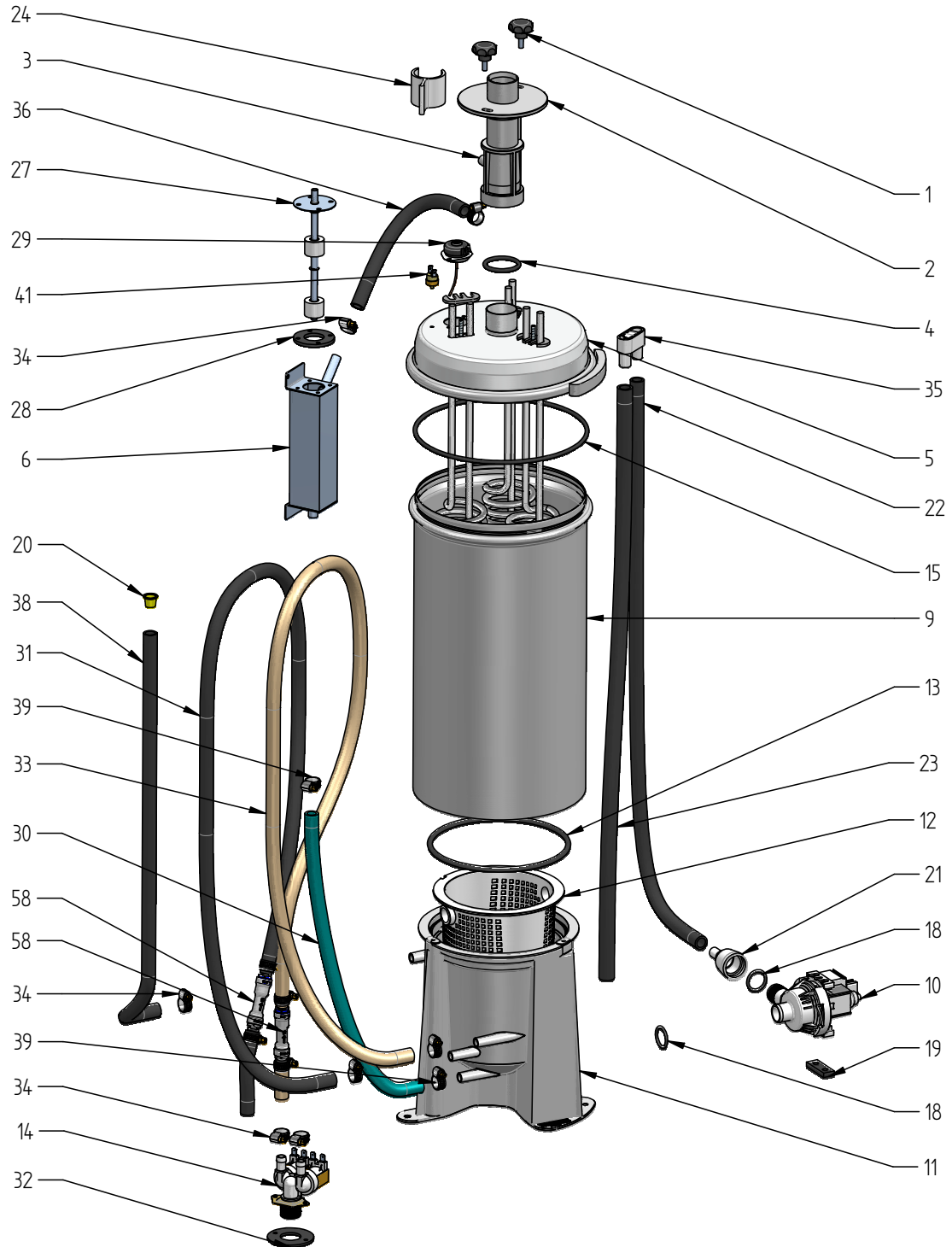

## 15. View of Cabinet

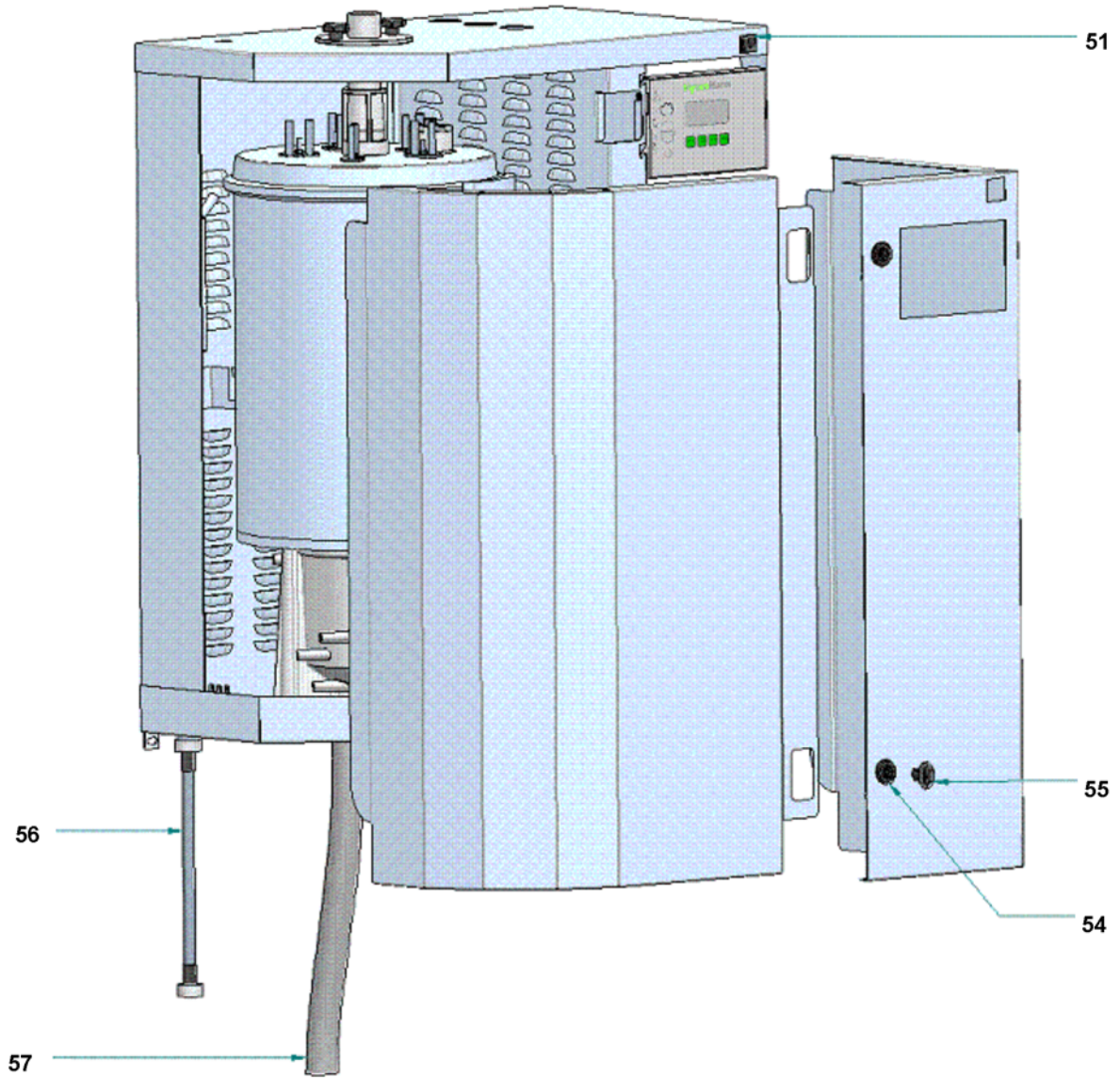



## 16. Technical Specifications

Type		HeaterLine HL								
		HL6	HL9	HL12	HL18	HL24	HL27	HL30	HL36	HL45
Data at 208V/3 Phase, 60Hz*	Steam Output [kg/h] [lbs/h]	4.9 11	X	9.8 22	14.7 32	19.6 43	X	X	X	X
	Power Rating [kW]	3.7	X	7.4	11.0	14.7	X	X	X	X
	Input Current [A]**	17.7	X	30.6	30.6	48.0	X	X	X	X
	Circuit Protection [A]	3 x 20	X	3 x 35	3 x 35	3 x 50	X	X	X	X
	Number of Heater Elements	1	X	2	3	4	X	X	X	X
Data at 480V/3 Phase, 60Hz*	Steam Output [kg/h] [lbs/h]	6.0 13	9.0 20	12.0 26	18.0 40	24.0 53	27.0 60	30.0 66	36.0 79	45.0 99
	Power Rating [kW]	4.5	6.8	9.0	13.5	18.0	20.3	22.5	27.0	33.8
	Input Current [A]**	9.4	14.1	16.2	16.2	25.6	24.4	32.5	38.4	47.6
	Circuit Protection [A]	3 x 10	3 x 15	3 x 20	3 x 20	3 x 35	3 x 25	3 x 35	3 x 40	3 x 50
	Number of Heater Elements	1	1	2	2	4	3	5	4	5
Data at 600V/3 Phase, 60Hz*	Steam Output [kg/h] [lbs/h]	6.0 13	9.0 20	12.0 26	18.0 40	24.0 53	27.0 60	30.0 66	36.0 79	45.0 99
	Power Rating [kW]	4.5	6.8	9.0	13.5	18.0	20.3	22.5	27.0	33.8
	Input Current [A]**	7.5	11.3	13.0	13.0	20.5	19.5	26.0	30.7	39.0
	Circuit Protection [A]	3 x 10	3 x 15	3 x 15	3 x 15	3 x 25	3 x 20	3 x 35	3 x 35	3 x 40
	Number of Heater Elements	1	1	2	3	4	3	5	4	5
Control voltage	Control voltage 24V/ 208-240V									
Number of steam cylinders	1									
Steam hose connection [mm] [inch]	1 x 25 1 x 1 **			1 x 40 1 x 1 1/2				2 x 40 2 x 1 1/2		
Condensate hose connection [mm] [inch]	1 x 12 1 x 1/2							2 x 12 2 x 1/2		
Net Weight [kg] [lbs]	36 79.4	36 79.4	37 79.4	38 83.8	40 88.2	40 88.2	48 105.8	48 105.8	49 108.0	
Max. operational weight [kg] [lbs]	51 112.4	51 112.4	52 114.6	53 116.8	55 121.3	55 121.3	78 172.0	78 172.0	79 174.2	
Dimensions	Height [mm] [inch]	830 32.7						855 35.0		
	Width [mm] [inch]	645 25.4						688 27.1		
	Depth [mm] [inch]	325 12.8						395 15.6		
Water supply	Fully Demineralized Water / Cleaned Condensate / Partially Softened Water / Tap Water (different qualities), 1bar min., 10bar max. / 14.5 psi min., 145 psi max., 13mm/1/2" Hose									
* Other voltages upon request. ** Reducing Piece DN40/DN25 included *** Current load of phases is not uniform. **** Outer dimensions of width and depth. Height incl. drain connection.										

Type		HeaterLine HL Double Units			
		HL 60	HL 70	HL 80	HL 90
consist of:					
HL 30	2 x				
HL 36		2 x	1 x		
HL 45			1 x	2 x	



**HyGROMATIK®**

Lise-Meitner-Str.3 • D-24558 Henstedt-Ulzburg  
Phone +49(0)4193/ 895-0 • Fax -33  
eMail [hy@hygromatik.de](mailto:hy@hygromatik.de) • [www.hygromatik.com](http://www.hygromatik.com)  
A member of the **spirax/sarco** Group