

Controls

Basic- DS

Comfort- DS

Comfort Plus- DS



IMPORTANT: READ AND SAVE THESE INSTRUCTIONS



DS.CSA
E-8881716

Certain computer programs contained in this product [or device] were developed by HygroMatik GmbH ("the Work(s)").

Copyright © HygroMatik GmbH [01.03.2017]

CSA: Basic-DS, Comfort-DS and Comfort Plus-DS

All Rights reserved.

HygroMatik GmbH grants the legal user of this product [or device] the right to use the Work(s) solely within the scope of the legitimate operation of the product [or device]. No other right is granted under this licence. In particular and without prejudice to the generality of the foregoing, the Work(s) may not be used, sold, licensed, transferred, copied or reproduced in whole or in part or in any manner or form other than as expressly granted here without the prior written consent of HygroMatik GmbH.

Information in this manual is subject to change or alteration without prior notice.

Current version of this manual can be found at: www.hygromatik.de/us

 WARNING**Risk of electrical shock!**

Hazardous electrical high voltage!

All electrical work to be performed by certified expert staff (electricians or expert personnel with equivalent training) only.

1. Introduction	5
1.1 Typographic Distinctions	5
1.2 Documentation	5
1.3 Symbols in Use	6
1.3.1 Specific Symbols related to Safety Instructions	6
1.4 Intended Use	6
2. Safety Instructions	8
2.1 Guidelines for Safe Operation	8
2.1.1 General	8
2.1.2 Unit control	8
2.1.3 Unit operation	8
2.1.4 Mounting, installation, maintenance, repair and dismantling of the unit	9
2.1.5 Electrical	10
3. Comfort- DS / Comfort Plus- DS	11
3.1 General View of DS-Control and Operating Panel	11
3.2 Communication with the Control	12
3.2.1 Function Keys	12
3.3 DS-Comfort and DS-Comfort Plus Compared	13
4. User Mode - Communication with the Control (Comfort-DS/ Comfort Plus-DS)	14
4.1 Changing Steam Bath Parameters in User Mode	14
4.1.1 Modifying the Temperature Set Value (G2)	14
4.1.2 Steam Bath Exhaust Fan (D1)	15
4.1.3 Essence Delivery System - Function (D2)	15
4.1.4 Light - Function	16
4.2 Overview of Steam Bath Operation and Installation	16
4.2.1 Steam Bath Installation (Schematic Layout)	17
4.2.2 Steam Bath - Temperature Control	18
4.2.2.1 Temperature Profile in Steam Bath Diagram	19
5. Operating Mode - Advanced Communication with the Control (Comfort-/Comfort Plus-DS)	20
5.1 Introduction to the Comfort- DS / Comfort Plus- DS Control	20
5.2 Software Menu and Parameter Setting	22
5.2.1 Access to Operating Mode	24
5.2.2 Function Keys	25
5.3 Operating Mode - Description of Accessible Parameters	25
5.3.1 Language Menu	26
5.3.2 Start-Up Menu	26
5.3.2.1 Control Parameters Submenu (under Startup Menu)	27
5.3.2.2 System Test Submenu (under Startup Menu)	29
5.3.3 Electronic Name Plate Menu	31
5.3.4 Parameter Setting Menu	32
6. Parameters	33
6.1 Summary Table of Parameters	33
6.2 Explanation of Parameters	35
6.2.1 Steam Bath Functions	35
6.2.1.1 Steam Bath Mode D0 (Operating Mode)	35
6.2.1.2 Exhaust Fan D1 (Operating Mode)	36
6.2.1.3 Essence D2 (Operating Mode)	36
6.2.1.4 Light D3 (Operating Mode)	37
6.2.1.5 Supply Fan D4 (Operating Mode)	37
6.2.1.6 Limitation of operating time D5	37
6.2.2 Steam Bath Parameters (G0 - G9, G13)	38
6.2.2.1 Calibration °C Actual °C (G0)	38
6.2.2.2 Hysteresis Controller (G1)	38
6.2.2.3 Steam Bath °C Set Value (G2)	38
6.2.2.4 Hysteresis Exhaust Fan (G3)	40

6.2.2.5 Time Essence Injection (G4)	40
6.2.2.6 Interval Time Essence Injection (G5)	40
6.2.2.7 Hysteresis Essence Injection (G6)	41
6.2.2.8 Hysteresis °C Max (G7)	41
6.2.2.9 Fan Run-On Time (G8)	41
6.2.2.10 Power Retention (G9)	41
6.2.2.11 Hysteresis Supply Fan (G13)	41
6.2.3 Humidifier Operating Parameters.	42
6.2.3.1 T0 Timer Mode (only available with Comfort Plus-DS Control)	47
6.2.3.2 Values and Operational Conditions.	49
7. Basic- DS	51
7.1 Basic Construction	51
7.1.1 Basic-DS Display Unit	51
7.2 Basic-DS Main PCB.	52
7.3 Parameter Setting with Jumpers.	52
7.3.1 Brief Description of Jumpers	53
7.3.2 Explanation of Jumper Functions.	54
7.3.3 Description of Potentiometer	57
7.3.3.1 Potentiometer P1 / Steam Generation Output Limitation	57
7.3.3.2 Potentiometer P2 / Pump Run Time	57
7.3.4 Potentialfree Outputs	57
7.3.4.1 Collective Fault - Base Relay	57
7.3.4.2 Humidification:.	58
7.3.4.3 Signal Output	58
8. Fault Messages (Comfort- DS / Comfort Plus- DS und Basic- DS).	59
9. For the Installer	62
9.1 Temperature Sensor Installation	62
9.1.1 Temperature Sensor Connection.	62
9.2 Installation of Essence Injector with Peristaltic Pump (Optional)	63
9.2.1 Connection for Essence Injector with 24V Peristaltic Pump Type EP24 (Optional)*	64
9.3 Fan Installation (Optional).	64
9.3.1 Connection for 24V Steam Bath Exhaust Fan (Optional)*	65
9.3.2 Connection for 24V Steam Bath Supply Fan (Optional)*	65
9.4 Cabin Light Installation (Optional).	65
9.4.1 Cabin Light Connection (Optional).	65
9.5 Remote Switch / Safety Interlock	66
10. Potential Free Signal Outputs	67
10.1 Base Relay and Signal Relay PCB capacity	67
10.1.1 Base Relay and Collective Fault	67
10.1.2 Signal Relay PCB and Steam Bath Functions*	67
11. Commissioning	69
12. Faults and Messages / Conditions	71
13. Basic PCB Connections	79
14. Terminal Assignments on the Unit Connector Strip and Wiring Diagram Legend.	81
15. Wiring Diagram	82
16. Ordering Information / Table of Options.	97
17. Technical Specifications	100

1. Introduction

Dear Customer,

Thank you for choosing a HygroMatik steam humidifier.

HygroMatik steam humidifiers represent the latest in humidification technology.

In order to operate your HygroMatik steam humidifier safely, properly and efficiently, please read these operating instructions.

Employ your steam humidifier only in sound condition and as directed. Consider potential hazards and safety issues and follow all the recommendations in these instructions.

If you have additional questions, please contact us:

Tel.: +49-(0)4193 / 895-0 (Main Number)

Tel.: +49-(0)4193 / 895-293 (Technical Support Hotline)

Fax: +49-(0)4193 / 895-33

e-mail: hotline@HygroMatik.de

For all technical questions or spare parts orders, please be prepared to provide unit type and serial number (see name plate on the unit).

1.1 Typographic Distinctions

- preceded by a bullet: general specifications.
- » preceded by an arrow: Procedures for servicing or maintenance which should or must be performed in the indicated order.
- Installation step which must be checked off.
- italics* Terms used with graphics or drawings.

1.2 Documentation

Retention

Please retain these operating instructions in a secure, always accessible location. If the product is resold, turn the documentation over to the new operator. If the documentation is lost, please contact HygroMatik.

Versions in Other Languages

These operating instructions are available in several languages. If interested, please contact HygroMatik or your HygroMatik dealer.

1.3 Symbols in Use

1.3.1 Specific Symbols related to Safety Instructions

According to ANSI Z535.6 the following signal words are used within this document:

▲ DANGER

DANGER indicates a hazardous situation which, if not avoided, will result in death or serious injury.

▲ WARNING

WARNING indicates a hazardous situation which, if not avoided, could result in death or serious injury.

▲ CAUTION

CAUTION indicates a hazardous situation which, if not avoided, could result in minor or moderate injury.

NOTICE

NOTICE is used to address practices not related to physical injury.

1.4 Intended Use

HygroMatik steam humidifiers serve for steam production using different tap water qualities or partial softened water (all humidifier types) or fully demineralized water/cleaned condensate (heater element humidifiers only).

Proper usage also comprises the adherence to the conditions specified by HygroMatik for:

- installation
- dismantling
- reassembly
- commissioning
- operation
- maintenance
- disposal.

Only qualified and authorised personnel may operate the unit. Persons transporting or working on the unit must have read and understood the corresponding parts of the Operation and Maintenance Instructions and especially the chapter 2. „Safety Notes“. Additionally, operating personnel must be informed of any possible dangers. You should place a copy of the Operation and Maintenance Instructions at the unit's operational location (or near the unit).

By construction, HygroMatik steam humidifiers are not qualified for exterior application.

 WARNING

Risk of scalding!

Steam with a temperature of up to 212 °F is produced.

Do not inhale steam directly in order to avoid respiratory damage!

2. Safety Instructions

These safety instructions are required by law. They promote workplace safety and accident prevention.

2.1 Guidelines for Safe Operation

2.1.1 General

Comply with the accident prevention regulation „DGUV Regulation 3“ to prevent injury to yourself and others. Beyond that, national regulations apply without restrictions.

2.1.2 Unit control

Do not perform any work which compromises the safety of the unit. Obey all safety notes and warnings present on the unit.

In case of a malfunction or electrical power supply disruption, switch off the unit immediately and prevent from restart. Repair malfunctions promptly.

▲ WARNING

Restricted use

This unit is not designed for the use by persons (also children) with limited physical, sensory and mental abilities - or without knowledge and experience - unless they are supervised or trained by a person, who is responsible for their safety. Supervise children in order to ensure that they will not play with the unit.

2.1.3 Unit operation

▲ WARNING

Risk of scalding!

In case of leaking or defective components, hot steam may exit in an uncontrolled manner.
Switch off unit immediately.

NOTICE

Risk of material damage!

The unit may be damaged if switched on repeatedly following a malfunction without prior repair.
Rectify defects in return!

- The unit must not be operated on a DC power supply
- The unit may only be used connected to a steam pipe that safely transports the steam (not valid device type Mini-Steam)
- Regularly check that all safety and monitoring devices are functioning normally
- Do not remove or disable safety devices

2.1.4 Mounting, installation, maintenance, repair and dismantling of the unit

▲WARNING

Explosion hazard!

Ignitable gas mixture may built up in the steam cylinder due to improper installation of essence feeding.

It is the responsibility of the unit installer and the steam bath provider to ensure that no condensated essence may drip from the steam pipe back into the steam cylinder. Essence line entry point in steam line must allow a 5 to 10% decline of essence line away from steam generator.

NOTICE

The HygroMatik steam humidifier is IP20 protected. Make sure that the unit is not object to dripping water in the mounting location.

When installation is made in a room without a drain, safety precautions must be taken in order for to shut off the humidifier's water supply in event of a leak.

- Use genuine spare parts only
- After any repair work, have qualified personnel check the safe operation of the unit
- Attaching or installing of **additional components** is permitted only with the **written consent** of the manufacturer
- The operator is responsible for the disposal of unit components as required by law

2.1.5 Electrical

⚠ WARNING**Risk of electrical shock!**

Hazardous electrical high voltage!

Any work on the electrical system must only be performed by qualified personnel.

Disconnect unit components from electrical power supply prior to work.

After electrical installation or repair work, test all safety mechanisms (such as grounding resistance).

NOTICE

Only use original fuses with the appropriate amperage rating.

Regularly check the unit's electrical equipment. Promptly repair any damage such as loose connections or burned wiring.

Responsibility for intrinsically safe installation of the HygroMatik steam humidifiers (steam generators) is incumbent on the installing specialist company.

3. Comfort- DS / Comfort Plus- DS

The display and operating panel enables local communication with the steam generator.

3.1 General View of DS-Control and Operating Panel



DS-Control Display and Operating Panel

The display is supplied as a four-line, lighted LC-display. Once the humidifier is switched on, it shows:

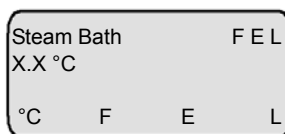

1st Line: Operating mode of the steam bath steam generator and status of **fan**, **essence** delivery and **light**.

2nd Line: active temperature in the cabin (°C)

3rd Line: normally blank

4th Line: function settings for the fan, essence delivery system and light

The humidifier operational conditions **steam production / humidification / filling** and **blow-down** can also be displayed and are indicated by the three middle yellow LEDs on the operating panel (see graphic below).

In case of a steam generator malfunction, the topmost red LED blinks. The control automatically shuts off the steam generator.

The lowermost green LED indicates that the steam humidifier is switched on and ready.

LED colors:

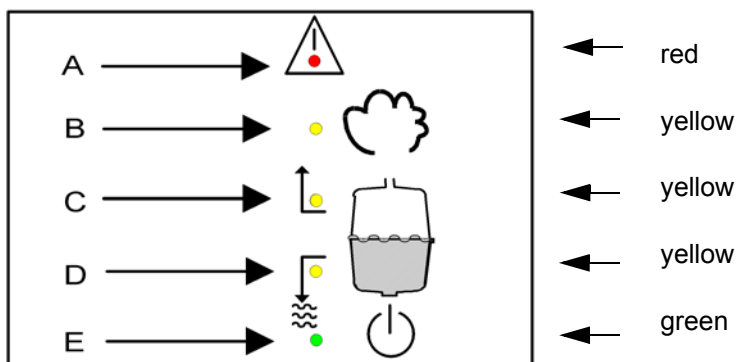

- A: Malfunction
- B: Steady LED = humidification; blinking LED = maximum water
- C: Filling
- D: Blow-Down
- E: Steady LED = ready; blinking LED = maintenance interval

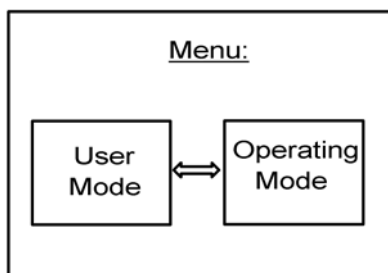

3.2 Communication with the Control

Local communication with the Comfort / Comfort Plus control (data input and output) is possible using the display and keypad.

Access modes for communication with the steam bath control are divided into:

- the **User Mode** (access for daily use), also see Section “User Mode - Communication with the Control”
- the **Operating Mode** (access for initial operation and maintenance), also see Section “Software Menu and Setting Parameters”

3.2.1 Function Keys



Keys  are located below the display. Above each key, a context-based action (software key) is shown on the lowest line of the display (i.e. an “°C” key). The action is performed by pressing the key. The software keys in the display unit enable parameter modification.

Keys

3.3 DS-Comfort and DS-Comfort Plus Compared

Comfort- DS



Comfort Plus- DS



Encoder Knob

Unlike the DS-Comfort, the DS-Comfort Plus is equipped with an additional encoder knob for easy use.

Turning the knob left or right is equivalent to pressing the software keys “up arrow” or “down arrow”.

Pushing down the encoder corresponds to pressing the software key “Enter”.





When using the encoder knob, an additional option for selection appears in the menus and submenus: “Back”. If the underscore (cursor) is located under “back” and the encoder knob is depressed, the control jumps to the next higher menu.

In addition, the Comfort-Plus Control features a timer function (Parameter T0), also see Section “Humidifier Operating Parameters”.

4. User Mode - Communication with the Control (Comfort-DS/ Comfort Plus-DS)

After switching on the steam humidifier, the user is placed in user mode.

This mode includes the indicators and controls needed to modify the following parameters:

- Temperature Set Value °C - (Key )
- Steam Bath Fan Function F - (Key )*
- Essence Delivery Function E - (Key )*
- Cabin Light Function L - (Key )*

*: no function for steam generators type C01 and C02

The active steam bath temperature is always simultaneously displayed.

Please note

For safety reasons, modifications to steam bath parameters in user mode are temporary, i.e. they are lost when the steam humidifier is switched off. Upon restart the unit operates with the previously entered parameter settings.

Stable parameter modifications are done in operating mode, also see Section "Operating Mode - Advanced Communication with the Control".

4.1 Changing Steam Bath Parameters in User Mode

⚠ WARNING

Risk of scalding!

Steam bath may achieve very high temperature. Before changing steam bath parameters, consider the consequences! Setting the desired steam bath temperature value too high may lead to serious injuries.

Steam bath operation and installation is described in the next section.

4.1.1 Modifying the Temperature Set Value (G2)

Please note

In user mode, the temperature may be modified in increments of 0.5°C.

Example: To reduce the desired temperature value from 45°C/113°F to 42°C/107.6°F.

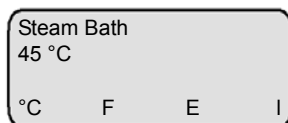

» Switch on steam generator. The display indicates the type of operation and the active cabin temperature.

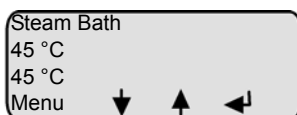

» Press  once. The programmed temperature value appears on the display.

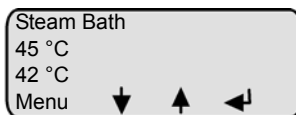

» Hold down  until the temperature value 42°C/107.6°F appears on the display.

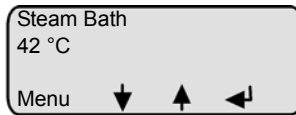

» Press  once.

The new temperature set value is programmed. After a few seconds, the program jumps back to the standard display. The display again indicates the active cabin temperature.

Please note Concerning Parameter G2, also see Section “Steam Bath Parameters (G0 - G9, G13)” .

4.1.2 Steam Bath Exhaust Fan (D1)

Automatic - Function

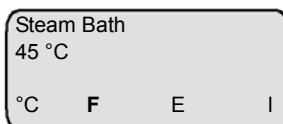

On the automatic setting, the fan operation is a function of the steam bath temperature. The control switches on the steam bath fan when the set temperature level is reached and switches it off again when the temperature falls below the set value, minus the hysteresis for the steam bath fan (Parameter G3).

Also see Parameters “Temperature Set Value” (G2) and “Hysteresis Steam Bath Fan” (G3). The **automatic** setting is preset in the factory and is indicated on the display by an **F**.

Please note More details to be found in the graph, also see Section “Steam Bath - Temperature Control”.

Continuous Operation (Continuous On) - Function

With this setting the steam bath fan operates continuously regardless of the temperature in the steam bath. Set this mode by pressing the

 key once after start-up.

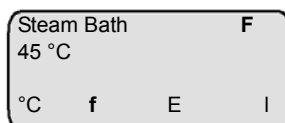

The display now indicates **f** for continuous operation of the fan. If an **F** is shown in the 1st line of the display, the fan is being controlled.

4.1.3 Essence Delivery System - Function (D2)

Automatic

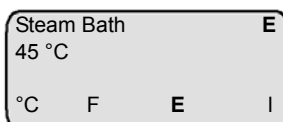

The **automatic** setting for the Parameter “Essence Injector” (D2) is indicated by an **E** in the display; essence is injected according to the programmed essence delivery interval (G5) and Injection Duration (G4). The factory setting for the essence delivery interval is 5 minutes and the setting for the essence injection duration is 2 seconds.

Delivery System Off

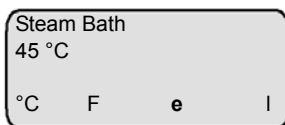

By pressing the  key once, the **Essence Injector** Parameter is set continuously to **off**. This is indicated in the display by an **e** and results in no essence delivery into the steam bath.

4.1.4 Light - Function

Light (on / off)

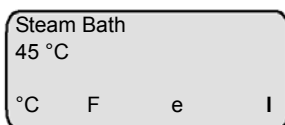

In the factory, the light in the steam cabin is switched off for initial operation. This is indicated by an **I** in the display. By pressing the  key once, the cabin light is switched on.

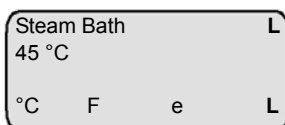

The display now shows an **L** to indicate continuous operation of the light. If an **L** is present in the 1st line of the display, the cabin light is operating.

4.2 Overview of Steam Bath Operation and Installation

The necessary steam for the operation of the steam bath is supplied by the HygroMatik Steam Generator. The recorded temperature in the steam bath is the only control variable for controlling steam production. At the default setting, the steam bath achieves a temperature of about 45°C/113°F at 100% relative humidity. A steam bath air supply fan may be used to deliver fresh air, and an exhaust fan to remove warm air from the steam bath, in order to ensure continuous steam supply and a stable temperature control.

Heat-Up Phase:

Steam is supplied to the still cold steam bath, increasing the relative humidity to 100% at an initially constant temperature. Subsequent steam delivery then increases the temperature; the relative humidity remains at 100%.

Operating Phase:

When the desired temperature (plus hysteresis) is reached, steam production is interrupted. If the steam bath temperature falls below the desired value, steam is again delivered into the cabin.

Please note The optional HygroMatik steam bath driving functions for light, fans and essence injection may be ordered in 24 V or 230 V versions. However, for installation within the steam cabin, only safe low voltage is allowed.

4.2.1 Steam Bath Installation (Schematic Layout)

Location	Designation
1	Steam generator
2	Essence peristaltic pump
3	Essence reservoir
4	Essence line to steam hose
5	T-piece for essence feed into the steam hose
6	Steam hose
7	Steam manifold in steam bath
8	bath supply fan
9	Temperature sensor
10	bath exhaust fan
11	Cabin light

Please note The illustration below depicts a schematic layout for a steam bath - it is not an installation instruction.



4.2.2 Steam Bath - Temperature Control

With any steam bath, a temperature sensor must be installed in the cabin. The temperature sensor measures the **temperature** in the steam bath and is connected to the steam generator.

The DS-Comfort or DS-Comfort Plus controls the HygroMatik steam generator according to the temperature reading. The **relative humidity** is not measured since it is **always 100%** following the heat-up phase.

In addition, depending on your order preference, you can connect an essence injector, light and fan to the steam generator.

The sample diagram below shows how the DS-Control functions:

Parameters G1 to G4 + G13 (may only be modified in operating mode) are programmed as follows:

Hysteresis Temperature Controller (G1)=	1K
Hysteresis Steam Bath Exhaust Fan (G3) =	1K
Hysteresis Steam Bath Supply Fan (G13) =	1K
Steam Bath Temperature Set Value =	45°C/113°F

If the temperature in the steam bath falls below **45°C/113°F**, an adjustment is made by increasing steam production.

If the temperature in the steam bath rises above **46°C/114.8°F**, steam production is shut off with 1-step operation or adjusted downwards with continuous operation.

The release point for the steam generator is determined as follows:

$$\text{Steam Bath } ^\circ\text{C Set Value (G2)+Hysteresis } ^\circ\text{C-Controller (G1) = } \\ 45^\circ\text{C}/113^\circ\text{F}+1\text{K} = 46^\circ\text{C}/114.8^\circ\text{F.}$$

If the temperature in the steam bath rises above the programmed temperature set value of 45°C/113°F, the DS-Control activates the steam bath exhaust fan. The control switches off the exhaust fan below 44°C/111.2°F. The release point for the steam bath exhaust fan is determined as follows:

$$\text{Steam Bath } ^\circ\text{C Set Value (G2) - } \\ \text{Hysteresis } ^\circ\text{C Steam Bath Exhaust Fan (G3) = } \\ 45^\circ\text{C}/113^\circ\text{F} - 1\text{K} = 44^\circ\text{C}/111.2^\circ\text{F}$$

Please note The Parameter “Steam Bath Exhaust Fan” (D1) must be programmed to „automatic“.

Steam is only produced as long as the temperature in the steam bath remains below the “set temperature value.” If the temperature in the steam bath remains above the “set temperature value” for a long period of time, resulting in this case in **no visible steam** production, this could be due to:

- excessively high heat supply from an additional source, e.g. from heated benches.
- a well-insulated steam bath
- too little air flow in the steam bath.

Air flow in the steam bath is facilitated by a steam bath exhaust fan, causing the temperature in the steam bath to fall more quickly. Renewed steam production compensates for the drop in temperature. In this way, the fan ensures constant, stable steam production - with visible steam in the cabin.

4.2.2.1 Temperature Profile in Steam Bath Diagram

Temperature Profile in Steam Bath

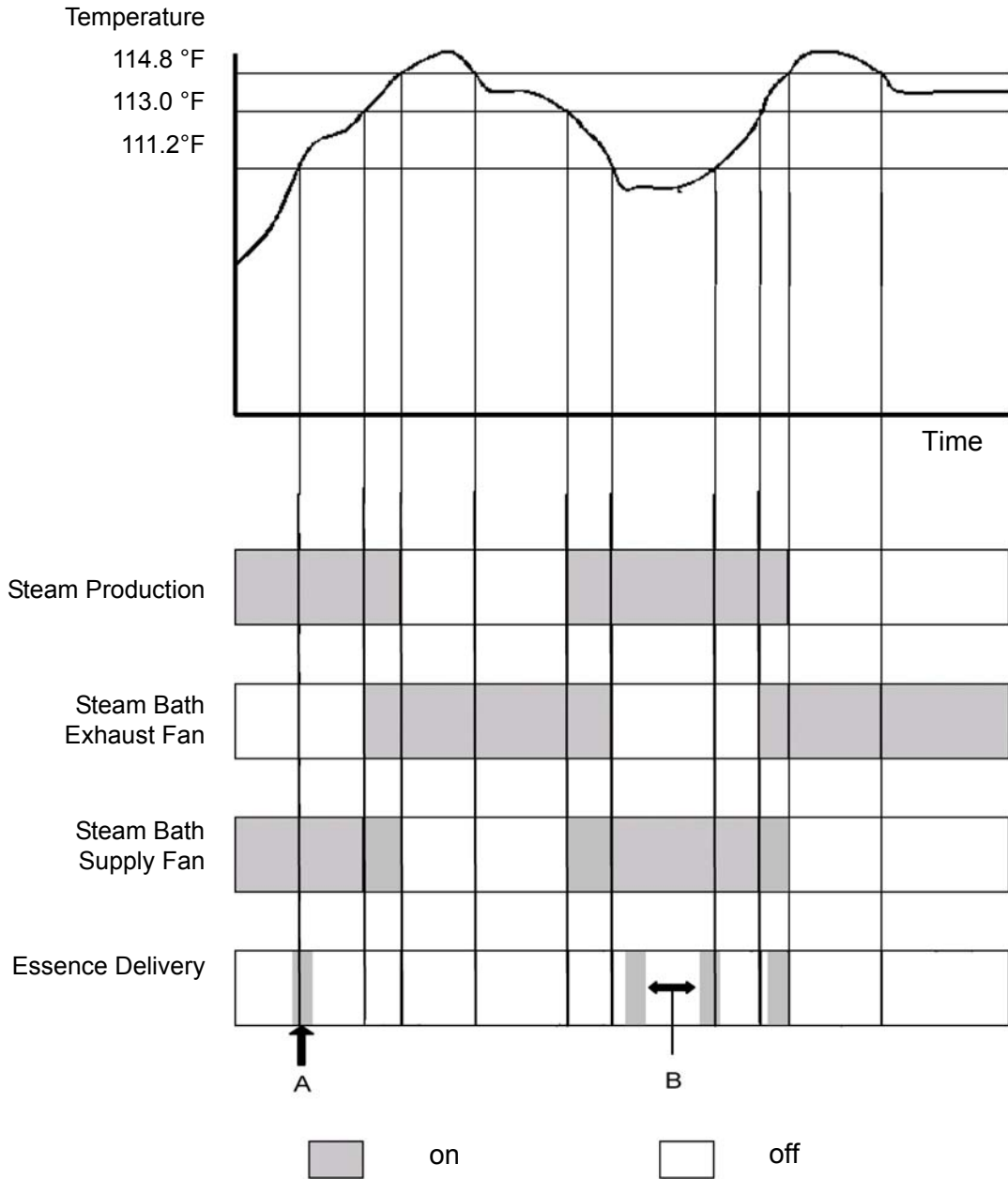

5. Operating Mode - Advanced Communication with the Control (Comfort-/Comfort Plus-DS)

5.1 Introduction to the Comfort- DS / Comfort Plus-DS Control

Control of your HygroMatik steam humidifier is performed by sophisticated microprocessors. These microprocessors intelligently and self-adaptively select the most economical mode of operation for the steam humidifier appropriate to the existing water quality. Optimized start-up procedures provide rapid steam production and quick responses to all control operations. The HygroMatik control regulates the complete blow-down procedure and the operation of the water inlet solenoid valve. For electrode steam humidifiers, it self monitors to control the conductivity of the cylinder water.

The HygroMatik microprocessor control Type DS supplies the user with all relevant data.

The Comfort- DS /Comfort Plus- DS Control features:

- a lighted alphanumeric LC-Display
- an (optional) RS232 or RS485 interface as the basis for the Modbus RTU protocol
- optimal adaptivity of the steam generator due to wide parameter adjustability
- 5 LEDs on the display panel give an instant overview of the most important operations
- Stand-by blow-down to prevent standing cylinder water. After a long period with no steam production, the cylinder is completely drained.
- 4 connections for control of the steam bath supply and exhaust fans, essence delivery system and light
- Remote control (optional)
- selection of steam bath operations with or without status indicator
- variable temperature control depending on operational mode



The performance options and available settings for your HygroMatik Control Type DS-Comfort and DS-Comfort Plus are explained below in detail.

Both the HygroMatik Comfort Control and the Comfort Plus consist of a main PCB and a display unit with back-lighted display, as well as an LED with icons and keys for direct communication with the control.

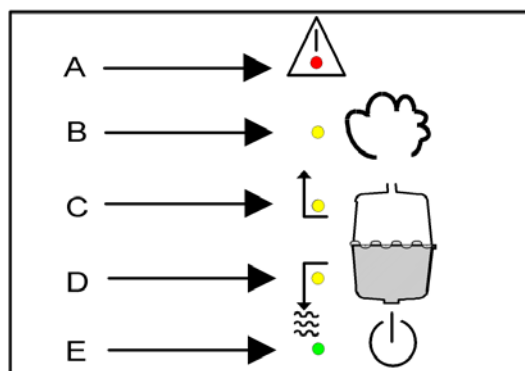

LED colors:
 red
 yellow
 yellow
 yellow
 green

A: Malfunction

B: LED steady = humidification; LED blinking = maximum water

C: Filling

D: Blow-Down

E: LED steady = ready; LED blinking = maintenance interval

The green LED blinks when the service interval has expired, and “Service” appears on the display. The maintenance interval can be adjusted to existing water quality. For more information, see “Setting the Maintenance Interval.”

Other information and functions can be called up by the panel keys.

Please note

After pressing a key the display lights up. After one minute without pressing any key the display goes back into stand by mode. (The display is dark.)

5.2 Software Menu and Parameter Setting

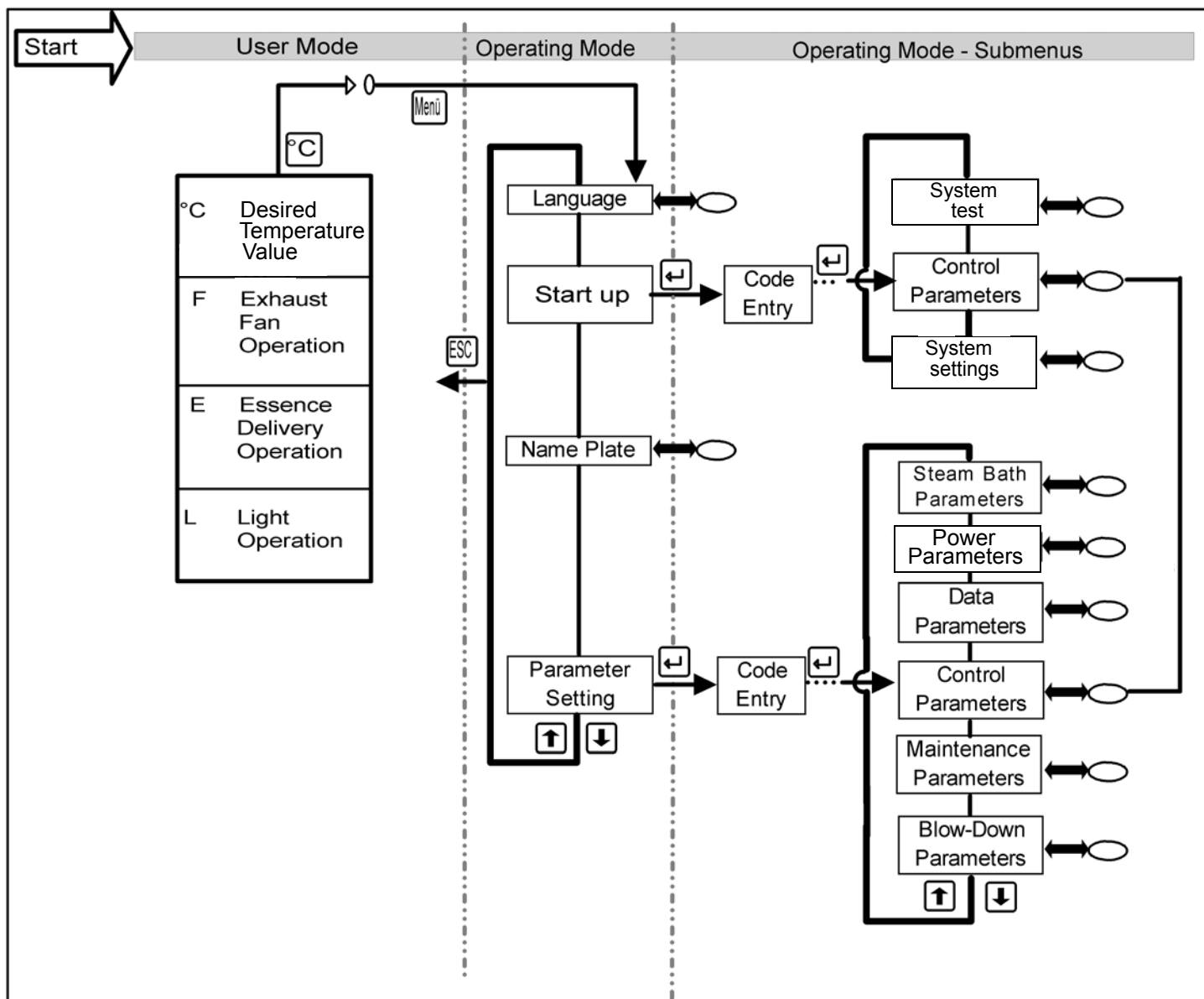

Explanation:

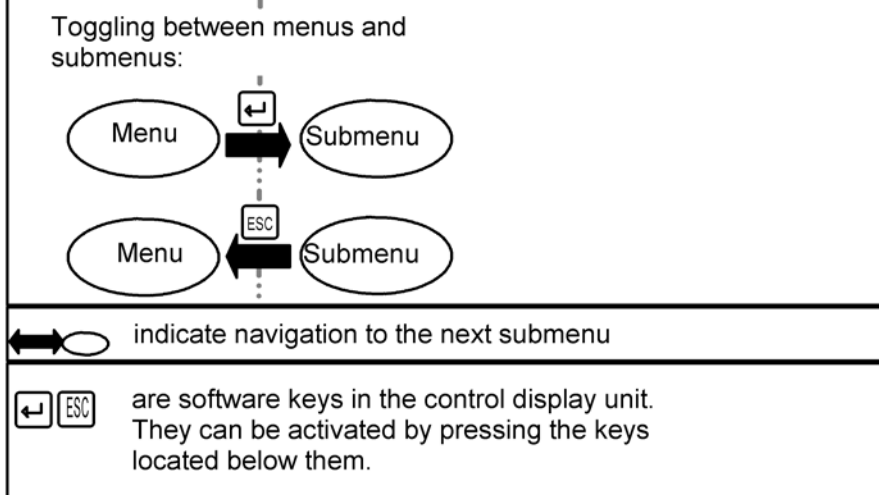

Local communication (data entry and readout) is possible with the Comfort / Comfort Plus Control using the display and the keypad.

The most important types of communication are:

- Readout/Modification of steam bath operational values (in User Mode)
- Selection of the active language (in Operating Mode)
- Readout of humidifier data (“electronic name plate”; in Operating Mode)
- Selection/Modification of essential parameters and system functions (in Operating Mode)

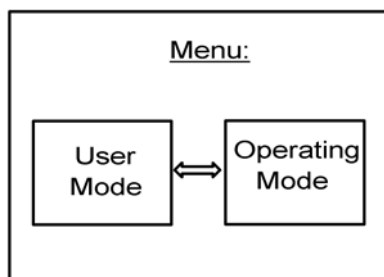

Access Options:

In **User Mode**, some parameters can be temporarily modified (Desired Temperature Value, Essence Delivery, Steam Bath Exhaust Fan Operation, Light Operation), also see Section: “Changing Steam Bath Parameters in User Mode”; all other parameters and system functions which have a critical impact on the proper operation of the humidifier are typically protected by an access procedure that requires entry of a code (P0=010).

5.2.1 Access to Operating Mode

After switching on the steam humidifier, the user is placed in user mode. The display shows the following:

User Mode



Operating Mode

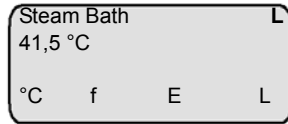



← Display

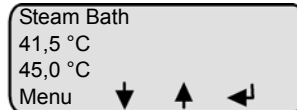

← Function

When the  key is pressed, the software key “C” is activated and the following display appears:







By pressing the  key again, the software key “Menu” is activated and the user accesses **Operating Mode**.





The sections below describe the configuration of the software menu, navigation through the menus, as well as display values, parameters and system functions.

5.2.2 Function Keys



Keys     are located below the display. Above each key, a context-based action (software key) is shown on the lowest line of the display (i.e. an “°C” key). The action is performed by pressing the key. The software keys in the display unit enable parameter modification.

Keys

Software Key Function	
	Access Menu Mode
	Back to previous menu level
	Reduce a value or “scroll up” within a menu or parameter list
	Increase a value or “scroll down” within a menu or parameter list
	Save or confirm a value / a figure or navigate to the subordinate submenu

5.3 Operating Mode - Description of Accessible Parameters

In Operating Mode, you have access to the following menus:

- Language
- Startup
- Name Plate
- Parameter Settings

5.3.1 Language Menu

In this menu, you can select the language in which you communicate with the humidifier.

Sprache / Language
German
English
French
Spanish
Japanese
Italian

Programming sequence to modify the language:

press  in Operating Mode,

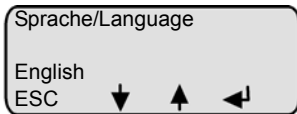
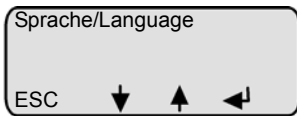

select the desired language with  or  and confirm with .

Exit the language menu with .

5.3.2 Start-Up Menu

The start-up menu comprises settings and parameters that may be needed for humidifier start-up.

The start-up menu is divided into two submenus:

- Control parameters
- Systemt test - the programming sequence initially follows sub-menu „control parameters“

5.3.2.1 Control Parameters Submenu (under Startup Menu)

Summary of Parameters:









Parameter	Description	Possible Settings	Access Code
U6	Controls	1 Step (On/Off) MODBUS Mehrstufig internal PI-controller	010
P1	Steam generation output limiter [%]	25-100%	010
E1*	Xp-PI-controller =100/E1 [Amplification]	[0- 100 %]	010
E2*	Tn-PI-controller [[Integration time]	[0- 255sec.]	010

* Only when internal PI-controller is activated

Programming sequence to modify the control parameters.

Please note The steps below make an essential change to a control parameter. If this is not intended, be sure to reestablish the original setting after changing it for exercising purposes. In any case, be aware of what you are doing!

Task: Parameter U6 is to be changed from “internal PI-controller” to “1-step”.

- » press  in Operating Mode,
- » press  or  until “Commissioning Parameters” appears on the display
- » press 
- » press 
- » press 
- » press 
- » press 

Sprache/Language
 ESC ↓ ↑ ←

Commissioning Parameters
 ESC ↓ ↑ ←

Commissioning Parameters
 Code 000
 ESC ↓ ↑ ←

Commissioning Parameters
 Code 000
 ESC ↓ ↑ ←

Commissioning Parameters
 Code 010
 ESC ↓ ↑ ←

Commissioning Parameters
 Code 010
 ESC ↓ ↑ ←

- System Test
 ESC ↓ ↑ ↵

»
press or until the submenu "Operation Mode Parameters" appears on the display
- Operation Mode Parameters
 ESC ↓ ↑ ↵

»
press
- Output limit
 P1: 100%
 ESC ↓ ↑ ↵

»
press or until Parameter U6 is displayed
- Operation Mode
 U6: internal PI controller
 ESC ↓ ↑ ↵

»
press
- Operation Mode
 U6: 1-step
 ESC ↓ ↑ ↵

»
press or to select "1-step"
- Operation Mode
 U6: 1-step
 ESC ↓ ↑ ↵

»
confirm with
- Operation Mode
 U6: 1-step
 ESC ↓ ↑ ↵

»
press to exit
- Operation Mode Parameters
 ESC ↓ ↑ ↵

»
press to exit the submenu
- Confirm change with Enter
 ESC ↓ ↑ ↵ Ja

»
the modification must be confirmed in order to be permanently saved; press to confirm
- Commissioning Parameters
 ESC ↓ ↑ ↵

»
press to exit the menu
- Steam bath
 41,5 °C
 45,0 °C
 Menü ↓ ↑ ↵

5.3.2.2 System Test Submenu (under Startup Menu)



This test enables checks of various humidifier functions (for example, during start-up).

The following test routines can be executed:

System Test
Automatic System Test (includes all stand-alone tests)
LED Test (stand-alone test)
Pump/MV test (stand-alone test)
Control Status Test (stand-alone test)

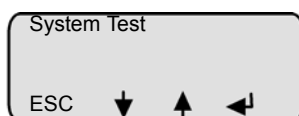
To select the “System Test” submenu (the initial programming sequence here is analogous to the description of navigation to the control parameters submenu):



» select the desired test routine with  or  and confirm with  - the test will be executed

Automatic System Test

The automatic system test performs all the stand-alone tests described below. Upon completion of each test, a message appears on the display for a few seconds. After this, the next test is performed.

LED Test

This test provides the ability to check the function of the LEDs. The LEDs **Humidifying**, **Filling**, **Blow-Down** and **Fault** are activated sequentially for a few seconds. Simultaneously, the component which corresponds to the LED is activated. For example, the water inlet solenoid valve is activated along with the LED Filling, or the collective fault relay is activated when the LED Fault is activated.

Pump/MV Test

This test checks the function of the inlet solenoid valve and blow-down pump. The following messages can be displayed:

Sample Display	Status
<div style="border: 1px solid black; padding: 5px; width: fit-content;"> Test Valve / Pump Fault Filling ESC ↓ ↑ ← </div>	Solenoid valve out of order or no water supply; also see Section: "Malfunctions and Messages". Fault Filling.
<div style="border: 1px solid black; padding: 5px; width: fit-content;"> Test Valve / Pump Blow-Down Fault ESC ↓ ↑ ← </div>	Blow-down pump out of order; also see Section: "Malfunctions and Messages". Blow-Down Fault.

Please note This test may take up to 30 minutes.

Control Status Test

This test checks whether the safety interlock is closed or has been released. For control configurations using an internal or external controller, the demand from the controller is also checked, also see Section: "Malfunctions and Messages".

Sample Display	Status
<div style="border: 1px solid black; padding: 5px; width: fit-content;"> Demand Test Release OK ESC ↓ ↑ ← </div>	Safety interlock is closed. Humidifier is operating with 1 step control.
<div style="border: 1px solid black; padding: 5px; width: fit-content;"> Demand Test Release off ESC ↓ ↑ ← </div>	Safety interlock activated (i.e. by Max.-Hygrostat). Humidifier is on stand-by.
<div style="border: 1px solid black; padding: 5px; width: fit-content;"> Demand Test 6,3 V 63% ESC ↓ ↑ ← </div>	Safety interlock is closed. No demand is present. The demand percentage is displayed. The humidifier is operating. *
<div style="border: 1px solid black; padding: 5px; width: fit-content;"> Demand Test no demand ESC ↓ ↑ ← </div>	No demand from the controller. The humidifier is on stand-by. *



* Only for control types (U6): external controller, internal PI-controller and internal PI-controller with max-limiter

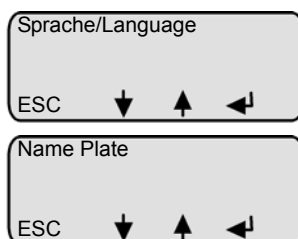

5.3.3 Electronic Name Plate Menu

The display can show 6 different sets of unit data.

Electronic Name Plate	
S1	Cylinder number
S2	Nominal capacity [kg/h]
S3	Software version
S4	Model type
S5	Year of manufacture
S6	Serial number
S10	Equipment designation



» press  in Operating Mode, press  in Operating Mode,

» press  or  until "Nameplate" appears in the display

» press  and then press  or  until the desired value appears on the display

5.3.4 Parameter Setting Menu

Parameters partly determine the humidifier's sequence of operations and processing of signals.

These parameters can be modified as needed.

For security reasons, access to some parameters is protected by an entry code. Two separate access levels have been defined:

Access Code 010

- "Basic customer level" without access code
- "Advanced customer level" with access code "010"

The "Parameter Setting" menu is divided into six submenus:

- Steam bath parameter
- Power parameter
- Data parameter
- Control parameter
- Maintenance parameter
- Blow-Down parameter

Once access to the "Parameter Settings" menu is gained by entering access code "010," an expanded set of parameters is available in comparison to access without a code entry.

See following pages for a summary table of parameters containing the information below:

- Parameter designation
- Possible parameter value settings
- Menu/submenu where the parameter is located
- Required access code for the parameter

At the end of the summary table, the parameters are described in detail; examples of programming sequences for parameter setting are provided with and without access codes.

Please note

Parameter modifications made and confirmed in Operating Mode are permanent. They also remain saved after the unit is deactivated.

6. Parameters

6.1 Summary Table of Parameters

Parameter	Designation	Possible Settings	in Menu / Submenu	Access Code
A4	Standby Blow-down	0 Min. - 999 Hours [HHH : MM]	Parameter Setting/ Blow-Down Parameters	none
A17	Stand-By heating	No/Yes	Start-up/System settings	010
C16	Interval time A17	0 - 999 min.	Settings/Power Parameter	010
C17	On time A17	0 - 255 sec.	Settings/Power Parameter	010
D0	Steam bath mode	“with status” / “without status”	Parameter Setting/Steam Bath Parameters	010
D1	Exhaust fan	Exhaust Fan Automatic / Continuous Operation	Parameter Setting/Steam Bath Parameters	010
D2	Essence (injection)	Essence Injection Automatic / off	Parameter Setting/Steam Bath Parameters	010
D3	Light	Light on/off	Parameter Setting/Steam Bath Parameters	010
D4	Supply fan	Supply Fan Automatic / Continuous Operation	Parameter Setting/Steam Bath Parameters	010
D5	limitation of operating time	0 - 255 h (0 is Factory setting (=off))	Parameter Setting/Steam Bath Parameters	010
E1*	Xp-PI-controller=100/E1 [Amplification]	0 - 100 %	Parameter SettingsControl Parameters	010
E2*	Tn-PI-controller [Integration time]	0 - 255 sec.	Parameter SettingsControl Parameters	
E5	Base relay (programmed switching signal)	0= collective fault (Factory Setting) 1= Fault Data Exchange 2= Humidification 3= Stand-By 4= Max. Level 5= Blow-Down Fault 6= Maintenance Interval Expired 7= Fault Filling 8= No Demand 9= ---- 10= ---- 11= Activated Thermo Sensor 12= Fault Main Contactor 13= Supply Fan 14= Exhaust Fan 15= Essence Injection 16= Light 17= Super Flush	Parameter Setting/ Data Parameters	010

Parameter	Designation	Possible Settings	in Menu / Submenu	Access Code
E6	1. Transmitting relay	same options as with E5, status 15 = factory setting	Parameter Setting / Data Parameters	010
E7	2. Transmitting relay	same options as with E5, status 14 = factory setting	Parameter Setting / Data Parameters	010
E8	3. Transmitting relay	same options as with E5, status 13 = factory setting	Parameter Setting / Data Parameters	010
E9	4. Transmitting relay	same options as with E5, status 16 = factory setting	Parameter Setting / Data Parameters	010
E17	baud rate (interface)	9600 / 4800 / 2400 / 1200	Parameter Setting / Data Parameters	010
G0	Calibration °C actual value	-5 to 5 K	Parameter Settings/ Steam Bath Parameters	010
G1	Hysteresis controller	0 - 10 K 1 K = Factory Setting	Parameter Settings/ Steam Bath Parameters	010
G2	Steam Bath °C set Value	0 - 55 °C 45 °C = Factory Setting	Parameter Settings/ Steam Bath Parameters	010
G3	Hysteresis exhaust fan	0 - 10 K 1 K = Factory Setting	Parameter Settings/ Steam Bath Parameters	010
G4	Time essence injection	0 - 25 sec. 2 sec. = Factory Setting	Parameter Settings/ Steam Bath Parameters	010
G5	Interval time essence injection	0 - 99 min. 5 min. = Factory Setting	Parameter Settings/ Steam Bath Parameters	010
G6	Hysteresis essence injection	0 -25 K 25 K = Factory Setting	Parameter Settings/ Steam Bath Parameters	010
G7	Hysteresis °C max.	0 -25 K 10 K = Factory Setting	Parameter Settings/ Steam Bath Parameters	010
G8	Fan run-on time	0 - 999 min. 0 min. = Factory Setting	Parameter Settings/ Steam Bath Parameters	010
G9	Power retention	0 - 100 % 0 % = Factory Setting	Parameter Settings/ Steam Bath Parameters	010
G13	Hysteresis supply fan	0 - 10 K 1 K = Factory Setting	Parameter Settings/ Steam Bath Parameters	010
H1	Counter Partial Blow-down	0 - 255 [Filling Cycle]	Parameter Setting/ Blow-Down Parameters	010
H2	Time Partial Blow-down)	0-255 [s]	Parameter Setting/ Blow-Down Parameters	010
H6	Full Blow-Down	Yes (On) No (Off)	Parameter Setting/ Blow-Down Parameters	010

Parameter	Designation	Possible Settings	in Menu / Submenu	Access Code
H11	Counter Partial Blow-down	0 - 999 kg	Parameter Setting/ Blow-Down Parameters	010
H12	Time Partial Blow-down	0-255 [s]	Parameter Setting/ Blow-Down Parameters	010
P1	Output limitation	25% - 100%	Parameter Setting/ Control Parameters	none
P2	Maintenance interval	0,1 - 25,5 [10 ³ kg]	Parameter Setting/ Maintenance Parameters	010
P3	Reset maintenance interval	Yes / No	Parameter Setting/Maintenance Parameters	010
P5	Address	1 - 999	Parameter Setting/ Data Parameters	none
P6	Operation timer	dddd:hh	Parameter Setting/ Data Parameters	none
P11	reset main contactor interval	Yes / No	Parameter Settings/Maintenance Parameters	010
T0	Timer mode (only with Comfort Plus)	Switch On and Switch Off Times (weekly, daily, off)	Parameter Setting/ Time Clock	010
U5	Pumping without K1	Yes (Main Contactor=off) No (Main Contactor=on)	Parameter Setting/ Blow-Down Parameters	010
U6	Operating mode	1-step internal PI-Controller	Parameter Setting/ Control Parameters	010

* Only when an internal PI-Controller is activated.

6.2 Explanation of Parameters

Please note

Parameters D1, D2, D3 and G2 may also be modified in User Mode; but the new settings will be lost when the unit is switched off.

6.2.1 Steam Bath Functions

6.2.1.1 Steam Bath Mode D0 (Operating Mode)

Possible Settings:

- with status
- without status

The DS-Control is designed for use with steam baths. Additional information (operational conditions) regarding steam generation may be useful for maintenance and initial start-up. If the operational mode is set to "with status", an operational condition is displayed in the 1st line of the display (also see illustration in Section "Operational Conditions (Dependent on Unit Type)" and readout values are displayed in the 2nd and 3rd lines of the display (also see illustration in Section "Readout Values").

6.2.1.2 Exhaust Fan D1 (Operating Mode)

- Possible Settings:**
- Automatic
 - On (Continuous Operation)
 - Off

Automatic

At this setting, fan operation is a function of the temperature in the steam bath. The control switches the exhaust fan on when the desired temperature is reached, and switches it off again when the temperature falls below the set value minus hysteresis.

Also see Parameters "Steam Bath °C set value (G2) and "Hysteresis fan (G3). If the fan is control-activated, the letter **F** is shown on the display.

On (Continuous Operation)

When in continuous operation, the fan runs independently of the temperature in the steam bath. In this setting, you use the control switch to simultaneously switch the fan and the steam generator on and off.

Off

The exhaust fan is deactivated on this setting.

6.2.1.3 Essence D2 (Operating Mode)

- Possible Settings:**
- On
 - Off

On

If Parameter "Essence Injection" (D2) is programmed to "**On**", essence is delivered according to the programmed Interval Time Essence Injection (G5) und Time Essence Injection (G4). At factory settings, the essence interval period is 5 minutes and the essence injection duration is 2 seconds.

Off

When Parameter "Essence Injector" (D2) is programmed to "deactivated," no essence is added to the steam.

6.2.1.4 Light D3 (Operating Mode)

Possible Settings: - On
 - Off

On

At this setting, the control continuously powers the cabin light.

The letter **L** appears in the display and **I** changes to **L** on the 4th line.

Off

At this setting, the cabin light remains off.

6.2.1.5 Supply Fan D4 (Operating Mode)

Possible Settings: - Automatic
 - On (Continuous Operation)
 - Off

Automatic

At this setting, fan operation is a function of the temperature in the steam bath. The control switches the supply fan off when the desired temperature plus hysteresis is reached, and switches it on again when the temperature falls below the set value.

Also see Parameters "Steam Bath °C Set Value" (G2) and "Hysteresis fan" (G3).

On (Continuous Operation)

When in continuous operation, the fan runs independently of the temperature in the steam bath. In this setting, you use the control switch to simultaneously switch the fan and the steam generator on and off.

Off

The supply fan is deactivated on this setting.

6.2.1.6 Limitation of operating time D5

Possible settings: 0-255 hours

Factory setting: 0 (=off)

With this parameter you determine if and when the steam generator should stop operation after the safety interlock has been closed. If the steam generator stops the message „Safety stop” is displayed. By opening and closing the safety interlock the steam generator restarts operation for the programmed hours.

6.2.2 Steam Bath Parameters (G0 - G9, G13)

Please note

Steam bath Parameters G0 - G9 and G13 can only be accessed on the parameter lists with a code (Code 010).

6.2.2.1 Calibration °C Actual °C (G0)

Using this Parameter, one can calibrate the temperature sensor connected to terminals 6 and 7.

Please note

The sensor is calibrated at the factory. Readjustment with a 2nd. temperature gauge is possible within a range of -5K to +5K.

6.2.2.2 Hysteresis Controller (G1)

Using this parameter, you can modify the differential between the activation and deactivation points of the temperature controller. The steam generator shuts off at a temperature of **Steam Bath °C Set Value (G2) + Hysteresis Controller (G1)**.

Example: G2 is set to 45°C and G1 is set to 1 K. The steam generator shuts off at 46°C/114.8°F and switches on again at 45°C/113°F.

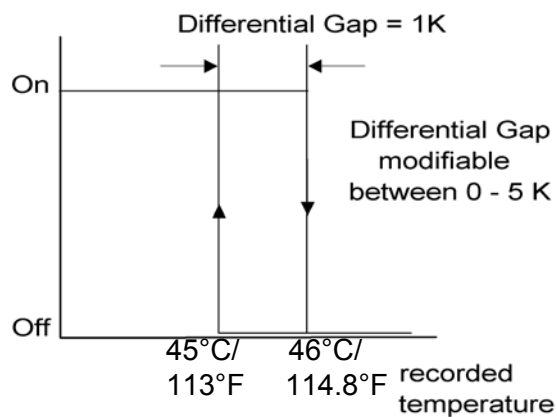

6.2.2.3 Steam Bath °C Set Value (G2)

Using this parameter, you can set the desired temperature in the steam bath. Changes to this setting in Operating Mode are saved when the steam generator is switched off.















Modifying set Temperature Value (G2)

Please note

The temperature may be modified in increments of 1°K in the main menu.

Example: The desired temperature value should be reduced from 45°C/113°F to 42 °C/107.6°F.

To do this, proceed as follows:

- » press  in Operating Mode
- » select "Parameter Settings" menu with  or 
- » enter the "Parameter Settings" menu with 
- » the access code (P0=010) to the advanced customer level must be entered; press 
- » press 
- » press 
- » select the "Steam Bath Parameters" submenu with  or 
- » enter the "Steam Bath Parameters" submenu with 
- » select Parameter G2 "Steam Bath °C Set Value" with  or 
- » enable Parameter G2 with 
- » press  twice to move the cursor under the third digit
- » press  three times to reduce the value from 5 to 2

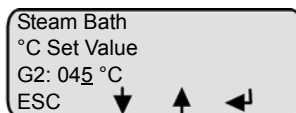
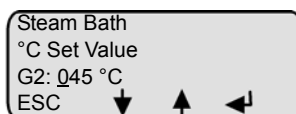
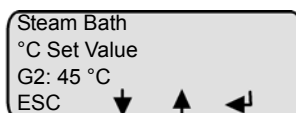
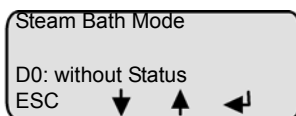
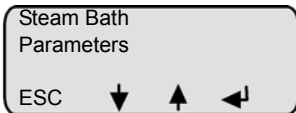
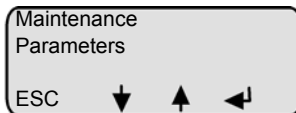
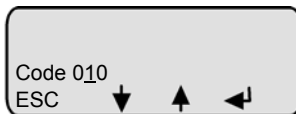
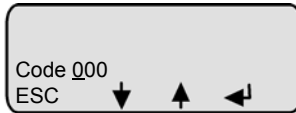
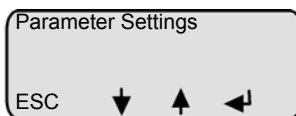
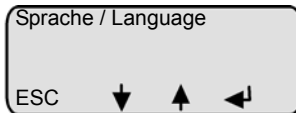

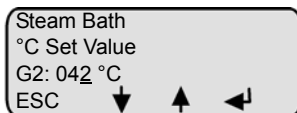

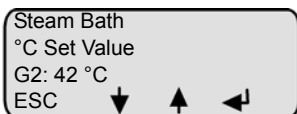

» Finish entry of value with 

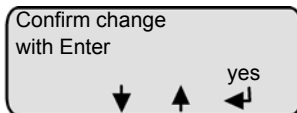

» Press  twice to exit the submenu



» the modification must be confirmed to be permanently saved;

to do this press 

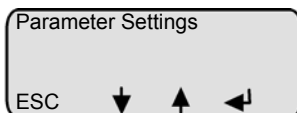

» press  to exit the menu

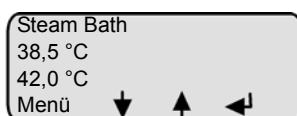

Values between 0 and 65 °C are programmable. The preset value for G2 is 45 °C.

6.2.2.4 Hysteresis Exhaust Fan (G3)

This parameter sets the release point for the fan during steam bath operation. The fan shuts off when the steam bath temperature falls to the value “Steam Bath °C Set Value (G2) - Hysteresis Exhaust Fan (G3)”.

Example: G2 is set to 45 °C and G3 is set to 2 K. The fan switches off at 43 °C/109.4°F.

The preset value is 1 K. Values between 0 and 10 K are possible.

6.2.2.5 Time Essence Injection (G4)

This parameter is used to set the duration [sec.] of essence delivery.

Values between 0 and 25 seconds may be programmed. The preset value is 2 seconds.

Please note For Parameters G2 - G4, please also consult the graph in Section “Steam Bath - Temperature Control”.

6.2.2.6 Interval Time Essence Injection (G5)

Use this parameter to set the interval period [min.] between essence injections.

Values between 0 and 99 minutes are possible. The preset value is 5 minutes.

6.2.2.7 Hysteresis Essence Injection (G6)

With this parameter, you set the cabin temperature at which essence delivery is enabled. The essence system is released to operate at a temperature value of **Steam Bath °C Set Value (G2) - Hysteresis Essence Injection (G6)**.

Example: G2 is set to 45°C/113°F and G6 is set to 25 K. Essence delivery release occurs at 20 °C/68°F.

Values between 0 and 25 K are programmable. The preset value is 25 K.

6.2.2.8 Hysteresis °C Max (G7)

With this setting, you set the maximum cabin temperature at which the steam generator must be shut off as a safety precaution.

Example: G2 is set to 45°C/113.0°F and G7 is set to 10 K. The steam generator shuts off at 55°C/131.0°F.

Values between 0 and 25 K are possible. The preset value is 10 K.

6.2.2.9 Fan Run-On Time (G8)

With this parameter, you determine if and how long the fan should run after the safety interlock opens.

Using Fan Run-On Time (G8) when Exhaust Fan (D1) is set to "Automatic", the fan is continuously enabled for the Run-On Time Delay (G8) by the opening of the safety interlock.

Values between 0 and 999 minutes are programmable. The preset value is 0 minutes.

6.2.2.10 Power Retention (G9)

With this parameter, you determine whether the steam generator will shut off when the desired steam bath temperature is reached, or whether it will switch over to an adjustable power retention of 0-50%. The power retention continues operating until the temperature falls below the value Steam Bath °C Set Value (G2). If too high a power retention causes the Steam Bath °C Set Value + Hysteresis Max. °C (G7) to be exceeded, the control deactivates with the **Fault °C Max**.

Please note

Power retention is intended as compensation for a cooling sensation due to continuous fresh air supply.

The preset value is 0 %.

6.2.2.11 Hysteresis Supply Fan (G13)

The fan is activated until the programmed value Steam Bath °C Set Value (G2) + Hysteresis Supply Fan (G13) is reached. If the temperature rises above this value, the supply fan is switched off again.

Values between 0 and 10 K are possible. The preset value is 1 K.

6.2.3 Humidifier Operating Parameters

P1 Output Limitation

The steam output can be set to a value between 25% and 100% of nominal capacity using the steam generation output limitation. The actual steam output released depends on the control signal.

Limitation of the steam output may be needed for better control.

Example: The steam generation output limitation should be reduced from P1 = 100% (factory setting) to P1 = 70%.

	» press in Operating Mode
	» press or until "Commissioning Parameters" appears in the display
	» press
	» press
	» press
	» press
	» press
	» press or until the "Operation Mode Parameters" submenu appears in the display
	» press
	» press again to select P1
	» press and then set the first digit to 0; then press

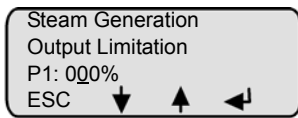

» the cursor is now located below the 2nd. digit, press 3 times to set the 2nd. digit to 7; then press

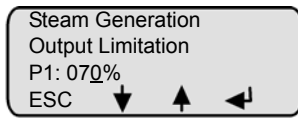

» now the cursor is located below the 3rd digit, press to finish modifying P1

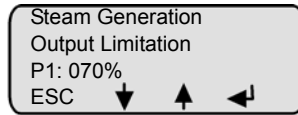

» press

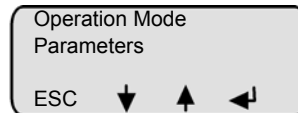

» press to exit the submenu

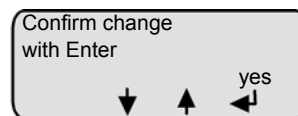

» the modification must be confirmed to be permanently saved;

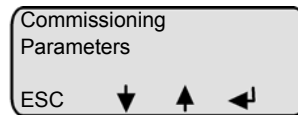

to do this press

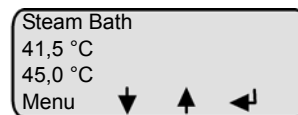

» press to exit the menu

P3 Reset Maintenance Interval

After maintenance, reset the service interval as shown below (green LED is still blinking):

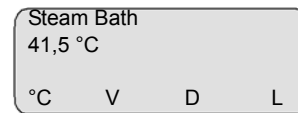

» press

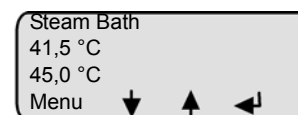

» press

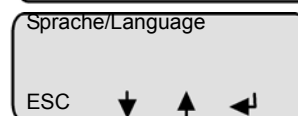

» press or until "Parameter Settings" appears in the display

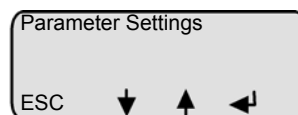







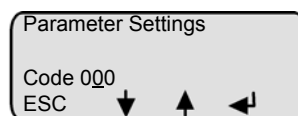



» press



» press



» press

Parameter Settings Code 010 ESC ↓ ↑ ←	»	press 
Parameter Settings Code 010 ESC ↓ ↑ ←	»	press 
Maintenance Parameters ESC ↓ ↑ ←	»	press 
Wartungs Intervall P2: 3:00 ESC ↓ ↑ ←	»	press 
Maintenance Interval P3: No ESC ↓ ↑ ←	»	press 
Reset Maintenance Interval P3: No ESC ↓ ↑ ←	»	press 
Reset Maintenance Interval P3: Yes ESC ↓ ↑ ←	»	press 
Reset Maintenance Interval P3: Yes ESC ↓ ↑ ←	»	press 
Maintenance Parameters ESC ↓ ↑ ←	»	press  to exit the submenu
Confirm changes with Enter ↓ ↑ ← ^{yes}	»	the modification must be confirmed to be permanently saved; to do this press 
Parameter Settings ESC ↓ ↑ ←	»	press  to exit the menu
Steam Bath 41,5 °C °C F E L		

A4 Stand-By Blow-Down

If the controller or hygostat demands no humidity from the humidifier for a long period of time, it is advisable to flush out the cylinder water. At Parameter A4 Stand-By Blow-Down, the time period is set after which the complete blow-down is automatically performed. Water will not be fed into the cylinder until a new demand signal is received.

A17 Stand-by heating

The stand-by heating keeps the cylinder water warm when no request is pending. The heating takes place if the safety chain is closed at intervals according to parameter C16 for the heating time according to parameter C17.

C16 Interval time A17

The C16 parameter defines the length of the pause time between the phases of the stand-by heating (active only if A17 = Yes).

C17 On time A17

The C17 parameter defines the length of the heating period for the stand-by heating (active only if A17 = Yes.)

E1 Xp-PI-Controller

Boosting PI-controller = $100/E1$ [$Xp = 0 - 100\%$]

E2 Tn-PI-Controller

Reset Time PI-controller [$Tn = 0 - 255$ sec]

E5 Base Relay

The base relay provides a potentialfree two-way contact at terminals 28, 29 and 30 (rated load: 250V/8A) (see page 59).

It is activated if certain operational conditions apply. The operational condition "collective fault" is preset.

It is possible to associate another operational condition with the base relay circuit, also see Section: "Summary Table of Parameters" on Page 35, "Parameter E5."

E6 1. Transmitting Relay

The switching function of this relay is factory set to "Essence Injection" and should not be modified.

The base relay provides a potentialfree two-way contact at terminals 31, 32 and 33 (rated load: 250V/8A).

E7 2. Transmitting Relay

The switching function of this relay is factory set to “Exhaust Fan” and should not be modified. The base relay provides a potentialfree two-way contact at terminals 34, 35 and 36 (rated load: 250V/8A).

E8 3. Transmitting Relay

The switching function of this relay is factory set to “Supply Fan” and should not be modified. The base relay provides a potentialfree two-way contact at terminals 37, 38 and 39 (rated load: 250V/8A).

E9 4. Transmitting Relay

The switching function of this relay is factory set to “Light” and should not be modified. The base relay provides a potentialfree two-way contact at terminals 40, 41 and 42 (rated load: 250V/8A).

E17 Baud Rate

As an option, the Comfort / Comfort Plus can be supplied with an RS485 computer interface. Here one can set the required baud rate for data transfer.

H1 Counter Blow-Down (only for electrode humidifiers)

Using this parameter, one specifies how many solenoid valve cycles occur before a partial blow-down is performed. The preset value should only be modified in consultation with HygroMatik.

H2 Time Partial Blow-Down (only for electrode humidifiers)

Using this parameter, set the pump run time during partial blow-down. This is given as a specified blow-down time in seconds.

H6 Full Blow-Down

With this parameter, you turn the full blow-down function on and off. The setting “Blow-Down Yes” means that blow-down is switched on.

H11 Counter Partial Blow-Down (only for HeaterLine Type humidifiers)

Using this parameter, you specify the quantity of steam. After the steam humidifier has produced this quantity of steam, the control initiates a partial blow-down. The preset value should only be modified in consultation with HygroMatik.

H12 Time Partial Blow-Down (only for HeaterLine Type humidifiers)

With this parameter, you set the pump run time during partial blow-down. This is given as a specified blow-down time in seconds. The preset value should only be modified in consultation with HygroMatik.

P2 Maintenance Interval

The Comfort / Comfort Plus Control records the quantity of steam actually produced. The total steam quantity maintenance interval is saved in Parameter P2 Steam Amount Service Interval. If the humidifier has produced this quantity of steam, the green LED on the operating unit blinks continuously (service message). The frequency of maintenance depends primarily on the water quality (conductivity, carbonate deposits) and on the interim steam amount produced. The maintenance interval can be adjusted to the water quality using Parameter P2.

P5 Address

As an option, the Comfort DS / Comfort Plus DS can be equipped with an RS485 or RS232 computer interface. It forms the basis for the Modbus RTU protocol that is integrated in the control software. The required address for this can be set here.

P6 Operation Timer

With this parameter, the operating run time (= period during which the heating voltage is enabled) is given in format dddd:hh.

P11 Reset main contactor interval

After the preprogrammed number of operations of the main contactor (K1) the HygroMatik control provides the message "Maintenance K1". It is recommended to swap the main contactor and to put the message back. The programming sequence is done in a manner similar to the parameter "P3 Reset Service Interval".



6.2.3.1 T0 Timer Mode (only available with Comfort Plus-DS Control)

If the Timer Mode T0 is programmed to a daily or weekly period of operation and the external safety chain is closed the steam generator is released during the programmed periods. In these periods the steam generator produces steam (if the steam bath temperature is below the set temperature).

Setting the system time and date:

For commissioning and after changing the battery the current system time and date has to be set.

By pressing  in the time clock menu the system time is displayed.

Pressing  again allows to change the system time with  or .

Confirm entry with .

Afterwards the current system date can be displayed by pressing .





Changing the system date corresponds to the operating sequence for the system time.

Setting the Timer Mode

There are three possible settings for the time clock:

- **off:** time clock is disabled
- **weekly:** every day the steam generator is released for the same period of time
- **daily:** for each weekday the steam generator is released for a special period of time

The setting:

Within the submenu „Time Clock“ press  until „Timer Mode“ appears. Select the „Timer Mode“ submenu by pressing  and choose between the three possible settings with . By pressing  the chosen setting is stored. If a daily or weekly timer mode is chosen press  for putting in the respective switch-on and switch-off times [hh:mm] (T1 and T2 = weekly operating period; T3 and T16 daily operating period).

U5 Pumping without K1 (main contactor deactivated during blow-down)

With this parameter, one can specify the switching status of the “On” / “Off” contactor during blow-down. At the “on” setting, the control will switch off the contactor during the blow-down procedure. This setting could be useful if the power supply line is routed through a sensitive residual-current-operated circuit breaker (rccb).



U6 Operating Mode

With parameter U6, one can set the humidifier control type.

6.2.3.2 Values and Operational Conditions

If the operating mode is set to “with status” using Parameter D0 (see page 38), the operational conditions below are displayed in the 1st line of the display and a readout value is displayed in both the 2nd and 3rd lines.

Readout Values

Using  or , you can toggle between the readout values (L x) below:



Readout	
L15	Y1 (solenoid valve) operation cycles
L14	K1 (main contactor) operation cycles
L13	Working hour [dddd:hh]
L12	Output signal [%]
L11	Actual °C Value [°C]
L10	Set Value °C [°C]
L5	Output limitation [%max.output]
L2	Actual current [A]
L1	Steam output [kg/h]
L0	Steam amount[10 ³ kg]

Please note

Normally the display shows the operational conditions of the humidifier and a readout value. The readout value is selected as in the example below:

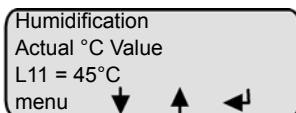
Example: The standard display should show the “actual value relative humidity” (L7):



- » Select the Actual °C Value (L11) with  or 
- » Confirm selection with 

Operational Conditions (dependent on unit type)

The display shows the following operational conditions:

Unit Type	
HyLine, CompactLine, MiniSteam	HeaterLine
- Humidification / Heating up	- Humidification / Heating up
- Stand-by	- Stand-by
- No demand	- No demand
- Filling	- Filling
- Partial blow-down	- Partial blow-down
- Stand-by blow-down	- Stand-by blow-down
- Dilution	- Max.-level
- Full blow-down	- Full blow-down
- Blow-down overcurrent	
- Safety stop	- Safety stop

Humidifying / Heating Up The steam humidifier produces steam if a demand from the hygrostat or controller is present (safety interlock must be closed).

After a humidifier cold start-up, or after a full blow-down, **Heating up** displays for a short time. The display reads **Humidifying** only after the first refill.

Stand-By

The safety interlock is open. The unit is producing no steam.

No Demand

The demand value from the controller is less than the activation point of the steam humidifier. The unit produces no steam.

Filling

The control activates the inlet solenoid valve. The cylinder is supplied with water.

Stand-by Blow-Down

If the controller or hygrostat demands no humidity from the humidifier for a long period of time, a full-blowdown is automatically performed after a specified period. This prevents standing water in the cylinder. The display shows Blow-Down. Set the time period using Parameter Stand-By Draining (A4).

Partial Blow-Down

In order to dilute the concentration of the cylinder water, the control regularly performs a partial blow-down.

Full Blow-Down

Depending on water quality, a complete blow-down is done every 3-8 days.

Blow-Down overcurrent

At cold start-up, the nominal current increases to a maximum of 128% in order to achieve a rapid start-up. When this current value is reached, a **power surge blow-down** is triggered and performs partial drainage of the cylinder.

Dilution

The **Dilution** message is displayed if an additional partial blow-down is required. This occurs for example at high conductivity levels, with a significantly fluctuating control signal, or when drainage is blocked.

Sicherheitsstop

Safety stop With this parameter you determine if and when the steam generator should stop operation after the safety interlock has been closed. If the steam generator stops the message „Safety stop” is displayed. By opening and closing the safety interlock the steam generator restarts operation for the programmed hours.

With parameter D5 you determine if and when the steam generator should stop operation after the safety interlock has been closed. If the steam generator stops the message „Safety stop” is displayed. By opening and closing the safety interlock the steam generator restarts operation for the programmed hours.

7. Basic- DS

If the steam humidifier is equipped with a control type Basic-DS the Basic-DS-display unit does not include any LC-display or keypad.

Communication between user and steam bath control is thus not possible. Changing parameters is only possible when connecting an optional available display (Comfort-DS-display) instead of the Basic-DS-display.

Please note

Chapters „User Mode - Communication with the Control (Comfort-DS/ Comfort Plus-DS) and „Operating Mode - Advanced Communication with the Control (Comfort-DS/ Comfort Plus-DS)“ do not apply to Control type Basic-DS.

7.1 Basic Construction

The HygroMatik control Type Basic-DS consists of a main PCB and a display unit with icons to describe the LED.

7.1.1 Basic-DS Display Unit



Using 5 LED, the display unit of the Basic-DS Control provides the user with information about operational conditions and fault messages:

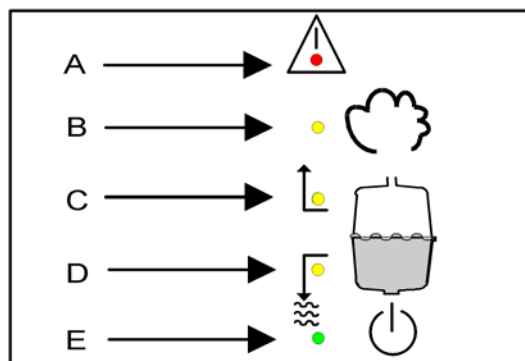

D: Blow-down (yellow LED)
 E: Stand-by (green LED)

LED B, C, D and E represent the following operational conditions:

LED B: Steam production (main contactor is switched)

LED C: filling water

LED D: draining water

LED E: power supply for control is on

The red LED A blinks to indicate a humidifier malfunction. The humidifier shuts off automatically, see Section „Malfunctions and Messages / Conditions“.

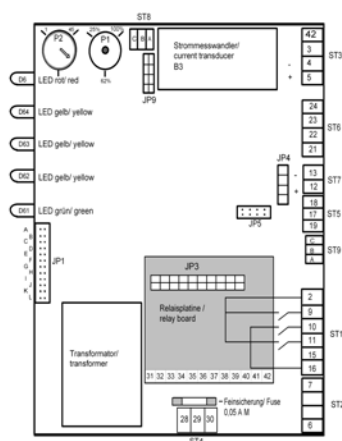

7.2 Basic-DS Main PCB

Also see the detailed illustration of the main PCB in chapter: „Basic PCB Connections“

On the main PCB, jumper strip JP1 and two potentiometers are located; control function is determined by how these are set. Descriptions of this appear in the following sections:

7.3 Parameter Setting with Jumpers

Normally, settings (parameters) for the Basic-DS Control can only be modified using jumpers.

Jumpers are electrical contact bridges that make connection between two open pins on the PCB.

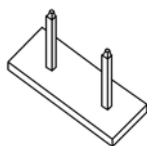

Jumper not set, contact open

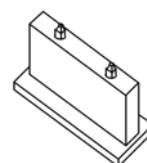

Jumper set, contact closed

A jumper position is referred to as “open” if the jumper is not set

NOTICE

Risk of material damage!

Change of jumper settings during unit operation may damage the control electronics or lead to unpredictable unit functioning.

Change jumper settings only when the system is turned off.

The jumper strip JP1 has 12 jumper positions, designated by the letters A to L.

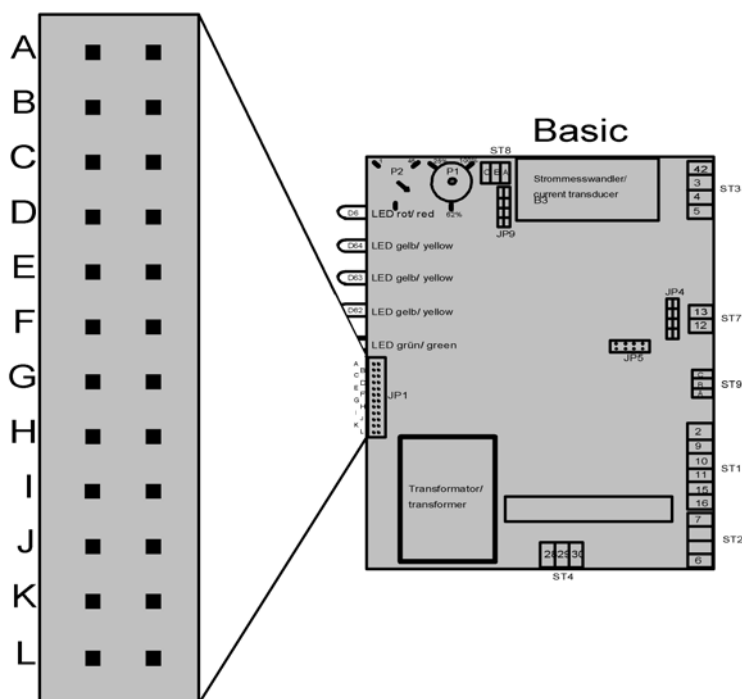

7.3.1 Brief Description of Jumpers

Jumper	Jumper Function
A	jumper must be open
B	jumper must be open
C	jumper must be open
D	Stand-by draining off
E	Main contactor switched off during blow-down
F	Less frequent partial blow-downs (-50%)
G	More frequent partial blow-downs (+100%)
H	Full blow-down switched off
F+G+H	Fully demineralized feed water
I	Factory setting: no jumper set
J	Factory setting: no jumper set
K	Factory setting: no jumper set
L	Factory setting: no jumper set

7.3.2 Explanation of Jumper Functions

Jumper A

The standard setting for this jumper is open.

Jumper B

The standard setting for this jumper is open.

Jumper C

The standard setting for this jumper is open.

Jumper D / Stand-By Blow-Down Off

If this jumper is not set, the “stand-by blow-down” function is active.

If the remote switch/safety interlock is open for a long while, an automatic stand-by complete blow-down occurs after a set period (24 hours).

The standard setting for the “stand-by blow-down” function is active.

Jumper E / Main Contactor Switched Off at Blow-Down

(Function only valid for electrode steam humidifiers)

The state of the circuit for the main contactor is specified with Jumper E.

Main contactor on: Jumper open
(standard setting)

Main contactor off: Jumper set

The setting “main contactor off” specifies that the electrodes are disconnected from the power supply during blow-down. This setting may be advisable if the power line is run through a residual current circuit breaker (FI).

Jumper F / Less Frequent Partial Blow-Down (-50%)

If this jumper is set, the “less frequent partial blow-down (-50%)” function is active.

The control periodically performs a partial draining of the cylinder (partial blow-down) in order to dilute the cylinder water; salt concentrates in it during routine operation because only pure water is evaporated.

If less conductive feed water is used (= lower salt content), it may be advisable to perform partial blow-downs less often to ensure that the humidifier always attains nominal steam output efficiently (only applies to electrode steam humidifiers).

Before modifying this parameter, please consult with HygroMatik.

Jumper G / More Frequent Partial Blow-Down (+100%)

If the jumper is set, the “more frequent partial blow-down (+100%)” function is active.

The control periodically performs a partial draining of the cylinder (partial blow-down) in order to dilute the cylinder water; salt concentrates in it during routine operation because only pure water is evaporated.

If highly conductive feed water is used (= higher salt content), it may be advisable to perform partial blow-downs more often in order to minimize electrode corrosion or remove more calcium build-up.

Before modifying this parameter, please consult with HygroMatik.

Jumper H / Full Blow-Down Switched Off

If this jumper is set, the “full blow-down switched off” function is active.

In addition to partial cylinder drainage (partial blow-down, see above), the control also performs a complete blow-down every 5-8 days of continuous operation.

If feed water with very low conductivity is used (= very low salt content), it may be advisable to deactivate the complete blow-down to ensure that the humidifier always attains nominal steam output efficiently (only applies to electrode steam humidifiers).

Before modifying this parameter, please consult with HygroMatik.

Jumper F+G+H / Fully Demineralized Feed Water

(this function is only valid for heater element humidifiers of Type HeaterLine)

If all three jumper are set, the “fully demineralized feed water” function is active.

No partial and total cylinder blow-downs are necessary when using fully demineralized water. The “fully demineralized water” function prevents blow-downs.

Please note

This function should not be activated when using electrode steam humidifiers of Type HyLine, CompactLine or MiniSteam.

Jumper I**Please note**

The standard setting for this jumper is open.

This jumper must not be set or only be set after consultation with HygroMatik.

Jumper J**Please note**

The standard setting for this jumper is open.

This jumper must not be set or only be set after consultation with HygroMatik.

Jumper K**Please note**

The standard setting for this jumper is open.

This jumper must not be set or only be set after consultation with HygroMatik.

Jumper L**Please note**

The standard setting for this jumper is open.

This jumper must not be set or only be set after consultation with HygroMatik.

Jumper E and J inverted

After a preprogrammed number of switching operations of the main contactor (K1), the HygroMatik control provides the message "Maintenance K1" indicated by the green LED rapidly flashing. The message may be reset (after changing the main contactor) by inverting the jumper E and J settings and, consequently, re-establishing the former status again. To do so, please turn off the unit and reverse the E and J jumper conditions, i.e. a jumper set must be removed and an open contact must be jumpered. Following this, turn on the unit for about 5 seconds. Then turn off the unit again and re-establish the preceding status of the jumpers. This resets the message.

7.3.3 Description of Potentiometer

7.3.3.1 Potentiometer P1 / Steam Generation Output Limitation

The control includes a Potentiometer P1 for setting the steam generation output limitation. Using the steam generation output limitation, the steam output can be set to a value between 25% and 100% of nominal output.

Limitation of steam output may be required for better control.

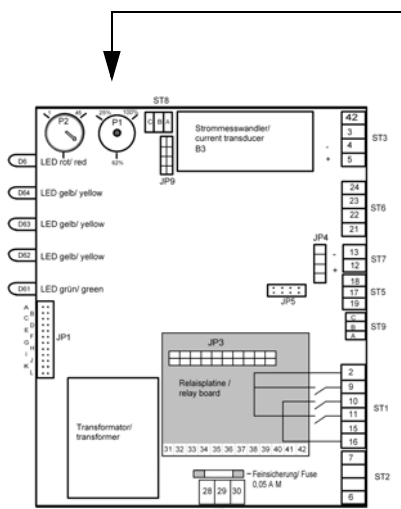

7.3.3.2 Potentiometer P2 / Pump Run Time

The control includes an additional Potentiometer: Potentiometer P2. This is used to set the pump run time during partial blow-down. The Potentiometer is properly set to the delivered humidifier type.

Depending on water quality, resetting the pump run time may be advisable. The following may apply:

very high conductivity of feed water = longer pump run time

very low conductivity of feed water = shorter pump run time

Please get in contact with HygroMatik before modifying this parameter.

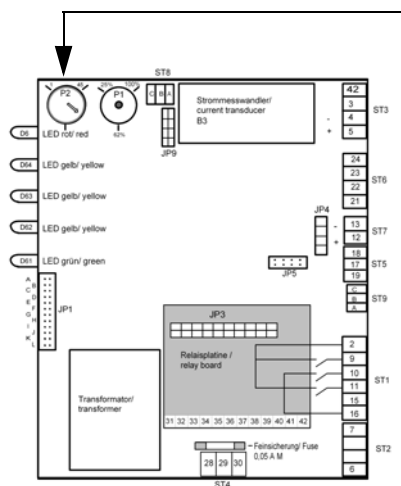

7.3.4 Potentialfree Outputs

The rated load of the relay contact is 250V/8A.

7.3.4.1 Collective Fault - Base Relay

The Basic-DS Control is normally supplied with a base relay programmed for a collective fault i.e. the base relay is triggered in case of a malfunction. The potentialfree contact is shipped as a two-way contact.

The connection terminal is located on the main PCB (normally closed contact: connection terminals 28 and 30; normally open contact: terminals 28 and 29).

The switching signal which switches over the base relay may be modified using Parameter E5 if an optional available LC-display is connected to the board instead of the normal Basic display.

For an overview of possible fault messages, see Section: “Summary Table of Parameters” on Page 52, description of Parameter E5.

The factory setting for the switching signal is “collective fault.”

7.3.4.2 Humidification:

The message “humidification” can be accessed directly on the main contactor as specified in the wiring diagram.

7.3.4.3 Signal Output

On the main PCB, a signal output is located at terminals 12 (+) and 13 (-).

The internal control signal of the humidifier is displayed as a proportional 0 - 10 V DC signal. This 0 - 10 V DC signal can be used as „external control signal“ for further humidifiers.

8. Fault Messages (Comfort- DS / Comfort Plus- DS und Basic- DS)

The control Comfort- DS / Comfort Plus- DS and also Basic-DS constantly monitor all important functions of the humidifier. In the case of a fault the humidifier switches off.

In case of a malfunction, the red LED blinks on the display and operating panel and one of the following messages is displayed (depending on unit type):

Fault Name		Unit Type	
		HyLine, CompactLine, MiniSteam	HeaterLine, Heater-Compact
Blow-down fault	F1	x	x
Thermo sensor activated	F2		x
Max.-level	F3		x
Fault filling	F4	x	x
RH Sensor fault	F6	x	x
Fault Sensor	F7		x
Maintenance	F8	x	
System Failure	F9	x	x
Fault main cont.	F10	x	x
Steam-down time	F11		x
Fault °C max.	F12	x	x
Lost Ground Control		x	x

(also see chapter „Faults and Messages“)

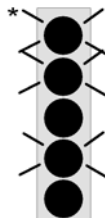
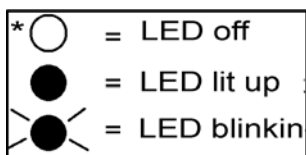

Fault °C sensor

If the recorded temperature remains outside the allowable temperature range of 0°C/32°F to 130°C/266°F (50.4 to 0.42 kOhm) for longer than 5 minutes, the control displays **Fault °C sensor**.

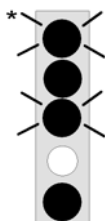

Fault °C Max

If the recorded temperature is higher than the maximum allowed cabin temperature for longer than 60 seconds, the control displays **Fault °C Max** and deactivates the steam generator.

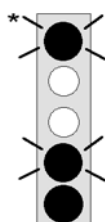

Blow-Down Fault

The control periodically activates the blow-down pump. If no water or insufficient water is flushed out during blow-down, the control displays **Blow-Down Fault**.

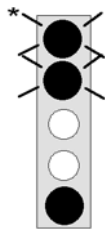

Fault Thermo sensor

If a thermo sensor has been tripped, the control registers this with the fault message “**Thermo sensor.**”

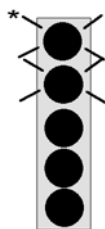

Fault Max. Level

If the water level in the cylinder reaches maximum five times within a five hour period, the control displays the fault **Max. Level.**

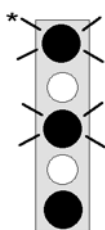

Fault Filling

The control activates the solenoid valve for a maximum of 30 minutes. The water in the cylinder should reach a specified level within this time period. If this is not the case, the control registers a **Fault Filling.**

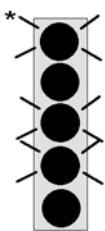

Fault sensor

Water level adjustment in HeaterLine type humidifiers is performed using two float switches and three reed contacts. If the control registers that the reed contacts have switched on or off in the wrong sequence, the display shows **Fault sensor.**

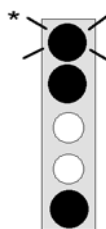

Fault steam-down

When steam is required, the electronics activates the solenoid valve in time intervals. If the electronics has not activated the solenoid valve over a period of many hours, the fault message “**Fault steam-down**” appears in the display.

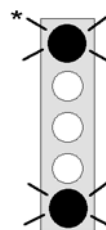

Maintenance

After one hour of operation at maximum water level, the control switches off the steam generator. The display shows **Maintenance.** In most cases, maintenance on the cylinder is required. The fault message “**Maintenance**” appears on the display.

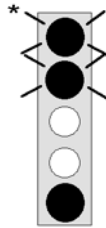

Fault Main Contactor

The control activates the main contactor if steam is required from the humidifier and the safety interlock is closed.

The control switches off the main contactor if the safety interlock is open or if steam is no longer required.

If the control detects current for a minimum of 15 seconds, even though the main contactor should have been deactivated, the control displays “**Fault Main Contactor.**”

The maximum water level message is typically displayed only when the main contactor is activated, i.e. if steam is required and the safety interlock is closed. If the control registers maximum water level for longer than 15 seconds, even though the safety interlock is open or no steam is required, the control displays “**Fault Main Contactor.**”

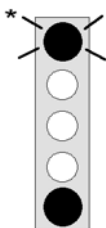

System failure

Mainboard is defective.

Lost Ground Control

Communication between main board and display is disturbed.

9. For the Installer

Please note Within the steam cabin, only safe low voltage (24V) is allowable.

9.1 Temperature Sensor Installation

With steam baths, a temperature sensor must be installed in the cabin. The sensor measures the active temperature and sends the value to the control. The recorded temperature constitutes a control variable for controlling steam production.

Please note Do not manipulate steam production by tampering with the temperature sensor (e.g. do not douse with cold water or cover).

General installation rules

- Do not install the sensor close to the steam manifold
- Mount the sensor on the wall and not in or under the wall paneling
- The best installation location for the temperature sensor is 800-1000mm/31.5-40 inch above the bench surface (about the head height of the steam bather)

9.1.1 Temperature Sensor Connection

Connect the temperature sensor cable to the designated terminals 6 and 7 on the HygroMatik steam generator.

Test using the table below. While the sensor has been calibrated in the factory, subsequent adjustment within a range of -5K to +5K is possible using a 2nd temperature gauge.

Temperature Resistance Table	
Temperature in °C/°F	Resistance in kOhm
10/50	28.5
20/68	18.5
30/86	12.3
40/104	8.3
50/122	5.8
60/140	4.1
70/158	2.9
80/176	2.1

9.2 Installation of Essence Injector with Peristaltic Pump (Optional)

⚠ WARNING

Explosion hazard!

Ignitable gas mixture may built up in the steam cylinder due to improper installation of essence feeding.

It is the responsibility of the unit installer and the steam bath provider to ensure that no condensated essence may drip from the steam pipe back into the steam cylinder. Essence line entry point in steam line must allow a 5 to 10% decline of essence line away from steam generator.

Please note

The DS-Control only controls the essence injector if the Parameter Essence Injector (D2) is set to „On“ (factory setting D2 = „On“).

The HygroMatik Essence Injector with peristaltic pump supplies the steam bath with essence. Its most important parts are the essence reservoir (3) and the peristaltic pump (2). The frequency and pulse duration of essence delivery can be set at the control unit. Essence delivery only occurs during steam production. The essence is injected into the main steam line (6) through an essence feed. HygroMatik supplies the necessary T-piece for this connection. If the hose is cracked or leaking, liquid is fed back into the steam reservoir via an essence return line.

General essence feed installation rules

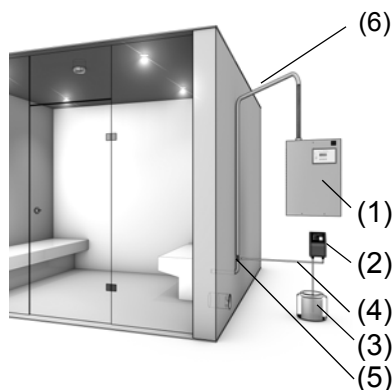

- Place essence feed (5) (s. also section „Steam Bath Installation (Schematic Layout)“) as close as possible to the steam bath
- Position the essence feed so that no essence can flow into the HygroMatik steam generator (1)
- Position peristaltic pump (2) above the essence reservoir (3), but no higher than 1.7m/67inch
- The essence feed (5) must not be located higher than 4m/158 inch above the essence pump

Installation steps

- » Install essence reservoir (3) in the proper position.
- » Install the peristaltic pump (2) above the essence reservoir (but no higher than 1.7m/67inch).
- » Install suction pipe between peristaltic pump (2) and essence reservoir (3).
- » Install essence return line between peristaltic pump (2) and essence reservoir (3).
- » Install line (4) between peristaltic pump (2) and essence feed (5).

9.2.1 Connection for Essence Injector with 24V Peristaltic Pump Type EP24 (Optional)*

Please note The DS-Control only controls the essence injector when Parameter D2 = On has been selected.



Peristaltic Pump EP24

Wire connection cable from the peristaltic pump to the steam generator to terminals 8, 9 and 13 (s. schematic diagram below). The EP24 peristaltic pump is protected by a 2.5 A micro fuse. Maximum contact load is 75W.

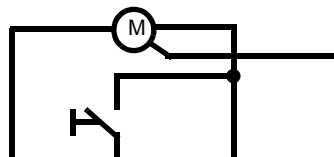

Peristaltic Pump EP24 (24V)	N	24V	24V Impuls	PE
	brown	black	grey	
Steam generator	8	13	9	24V

Connection diagram for HygroMatik peristaltic pumps type: EP24 (24V)

*: not valid for steam generators type C01 and C02

9.3 Fan Installation (Optional)

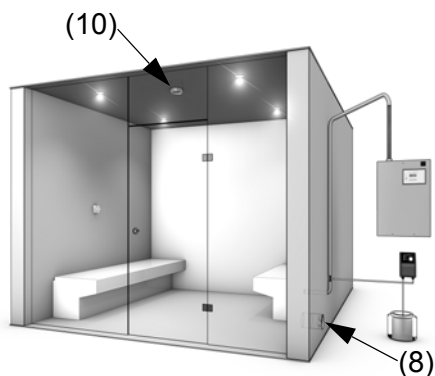

In any steam bath, an exhaust fan (10) (s. also section „Steam Bath Installation (Schematic Layout)“) should be installed. The fan removes warm air from the steam bath in order to ensure continuous steam supply and stable temperature control.

Depending on the configuration of the steam bath, an air supply fan (8) may also be operated.

In the steam bath, the exhaust fan should be installed:

- high up and
- across from the air supply vent

In the steam bath, the supply fan should be installed:

- down low and across from the exhaust vent

9.3.1 Connection for 24V Steam Bath Exhaust Fan (Optional)*

Connect fan cables to the designated terminals 10 and 11 (24V) in the steam generator. The fan is protected by a 1.6 A micro fuse. The maximum contact load is 40 W.

Please note

Using Parameter D1, the exhaust fan can be operated in automatic or continuous mode.

*: not valid for steam generators type C01 and C02

9.3.2 Connection for 24V Steam Bath Supply Fan (Optional)*

Connect fan cables to the designated terminals 10 and 12 (24V) in the steam generator. The fan is protected by a 1.6 A micro fuse. The maximum contact load is 40 W.

*: not valid for steam generators type C01 and C02

9.4 Cabin Light Installation (Optional)

Cabin lighting may also be connected to the steam generator.

9.4.1 Cabin Light Connection (Optional)

Connect cabin light cable to the designated terminals 13 and 14 (24 V supply voltage) in the steam generator.

The cabin lighting is protected by a 1.6 A micro fuse. The maximum contact load is 40 W. Switch lighting on and off using the software key **L** on the operating panel.

9.5 Remote Switch / Safety Interlock

Remote Switch

Terminals 1 and 2 are available for connecting an external on/off switch for the steam generator. Terminals 1 and 2 being bridged allows for operation of the steam generator. An open contact makes the steam generator idle.

Safety Interlock

The wiring loop between terminals 1 and 2 may be additionally used as a safety interlock. Circuit protection devices, for example an emergency shut-off switch or max.-thermostat, can be wired in here.

CAUTION

Risk of cabin overheating!

Defective temperature sensor may impede controller function. Use max.-thermostat in safety interlock to protect against overheating due to temperature sensor failure..

Circuit Protection Device



Humidifier Terminals

Safety Interlock and Remote Switch

In case of a circuit protection device **and** a remote switch to be used, wiring has to be made in series.

Remote Switch
Circuit Protection Device



Humidifier Terminals

Contacts across terminals 1 and 2 must be potential-free and comply with control voltage in use (24V or 230V).

Please note In factory setting, terminals 1 and 2 are unbridged.

10. Potential Free Signal Outputs

The DS control unit features a base relay and - optionally - a set of 4 additional relays on a dedicated PCB offering potential free contacts for signalling and switching purposes. Contact allocation may be taken from the tables below.

10.1 Base Relay and Signal Relay PCB capacity

Max. contact load is 250VAC/5A.

10.1.1 Base Relay and Collective Fault

The base relay (on the PCB) delivers a potentialfree two-way contact (load: 250V/8A) to terminals 28, 29 and 30.

Signal Relay / Contact	Contacts	Parameter for Selecting Switching Signal	Setting	Factory Setting for Switching Signal
Base Relay	28, 29, 30	E5	0	Collective Fault
Normally Closed Contact	28, 29			
Normally Open Contact	28, 30			

It is triggered when a specified operational condition is present. The preset operational condition is "Collective Fault."

It is possible, but not advisable, to assign another operational condition to the base relay / relay circuit (also see Summary Table of Parameters, Parameter E5).

Please note

If steam generators C01 or C02 are equipped with the "230V supply fan for C01 and C02" option or "230V exhaust fan for C01 and C02" option, the switching message „Collective Fault" is not available.

Humidification:

The message **humidification** can be directly accessed from the main contactor as indicated in the wiring diagram.

10.1.2 Signal Relay PCB and Steam Bath Functions*

The signal relay PCB is optionally attached to the main PCB of the DS-Comfort / Plus Control or the Basic-DS. The signal relay PCB provides four additional signal relays. Each relay is designed to control a specific steam bath component. Below are the factory settings for the relay switching functions:

*: not valid for steam generators type C01 and C02

Signal Relay / Contact	Contacts	Parameter for Selecting Switching Signal	Setting	Factory Setting for Switching Signal
1. Signal Relay Normally Closed Contact Normally Open Contact	31, 32, 33 32 33	E6	14	Essence Injector
2. Signal Relay Normally Closed Contact Normally Open Contact	34, 35, 36 35 36	E7	13	Steam Bath Exhaust Fan
3. Signal Relay Normally Closed Contact Normally Open Contact	37, 38, 39 38 39	E8	15	Steam Bath Supply Fan
4. Signal Relay Normally Closed Contact Normally Open Contact	40, 41, 42 41 42	E9	16	Light

The switching functions of the relays can be modified using parameters. However, the functions are not intended for modification as the wiring of the humidifier is configured for the factory settings.

Please note

Do not modify Parameters E6 and E9 except after consultation with HygroMatik, since this could lead to malfunctions.

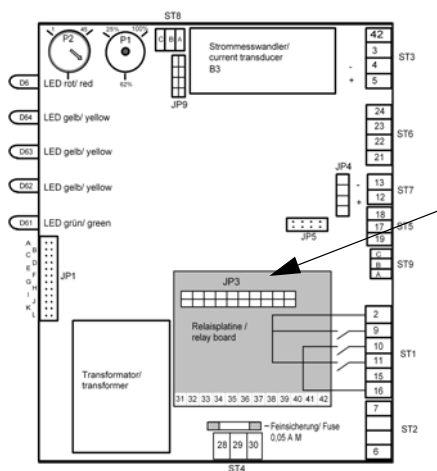

Retrofitting a Signal Relay PCB:

Plug the socket connector JP1 of the relay signal PCB into the socket base JP3 on the main PCB, so that the two holes on the signal relay PCB line up with the internal thread bolts (main PCB side).

Secure the signal relay PCB with the two screws provided.

11. Commissioning

⚠ WARNING

Risk of electrical shock!

Hazardous high electrical voltage!

Start-up of the unit is restricted to expert staff only (electricians or expert personnel with equivalent training).

Step 1: Check of mechanical integrity

- » Check cylinder seating.
- » Check steam and condensate hose clamps.

Step 2: Check of electrical wire connections

- » Check that all electrical wire connections (including steam cylinder wiring) are tight and secure.

Step 3: Switching on the steam humidifier

- » Switch on main breaker.
- » Open water supply stopcock (operating pressure should be 1bar min., 10bar max./14.5 psi min., 145 psi max.).
- » Switch on unit by setting control switch to "1".

Step 4: The unit performs a self-test

HygroMatik (R)
Self Test
LED Test

HygroMatik (R)
Self Test
Partial blow-down

Steam Bath
X.X °C
°C F E I

- The LEDs on the control panel light up briefly in succession .
- Subsequently, the blow-down pump is activated for a few seconds. This step checks pump operation and partial water exchange during restart (applies only to electrode steam humidifiers)
- After self-tests are completed, the display reads:

Please note

For the next steps, the **safety interlock** must be closed (see also chapter „Remote Switch / Safety Interlock) and the **temperature set-point** must be higher than the actual cabin temperature.

Step 5: Normal operation starts

the water solenoid valve opens and feeds water into the steam cylinder

Initiation of steam production may take up to 20 mins

- » Let all electrically-driven operations run to completion.

- As soon as the solenoid valve begins replenishing the water periodically, the steam humidifier operates at steady nominal output and the cold start sequence is completed

Step 6: Monitor unit for leaks

- » Let unit operate for 15 to 30 minutes.
- » If leaks appear, switch off the unit.

Step 7: Repair leaks

- » Repair leaks and check again.

12. Faults and Messages / Conditions

Please note

Record display message and switch off the unit immediately in case of malfunction.

The fault messages displayed depend on the humidifier type in use.

⚠ WARNING

Risk of electrical shock!

Hazardous electrical high voltage!

All electrical work to be performed by certified expert staff (electricians or expert personnel with equivalent training) only.

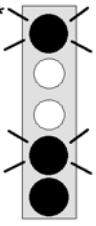
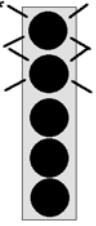
LED Display	HL*** HyC***	Message / Malfunction Displayed*	Probable Cause	Resolution
	X X	Fault Blow-Down Unit shuts off automatically	<ul style="list-style-type: none"> • Blow-down pump has not been electrically activated <ul style="list-style-type: none"> - Cable connections are faulty - The relay on the main PCB is not operating • Defective blow-down pump • Solenoid valve does not close properly. Water level in the cylinder sinks very slowly even though blow-down pump flushes out water. • Blow-down pump operates, but no water is pumped out, i.e. the cylinder drain is blocked. • Blow-down pump is blocked up with mineral deposits. 	<ul style="list-style-type: none"> • Check or replace cable connections • Measure voltage at the PCB terminals against N or replace PCB • Replace blow-down pump. • Check solenoid valve. • Thoroughly clean steam cylinder and base to prevent short-term blockage from reoccurring • Check blow-down pump, drain assembly and cylinder for mineral deposits and clean.
	X	Fault Max.-Level Unit shuts off automatically.	<ul style="list-style-type: none"> • If the water level "max. level" is reached, the pump switches on and drains the cylinder until the water level lowers to "operation." If the "max.-level" is reached five times, "max.-level" is displayed. • Air pressure in the duct is too high. Duct air pressure enters the cylinder via the steam hose. Water is forced into the drain. • Solenoid valve does not close properly. Water level in the cylinder rises slowly even though the solenoid valve has not been activated. • Water is supplied even though the steam humidifier is switched off. Solenoid valve remains open. • Inlet solenoid valve is receiving a constant electric signal. (If the unit is turned off, water feeding stops.) 	<ul style="list-style-type: none"> • Reduce air pressure or detach vent pipes from the unit and place higher • Check solenoid valve. • Clean solenoid valve. • The relay on the main PCB has stuck. Measure voltage at PBC-terminal 10 against 15.

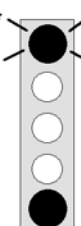
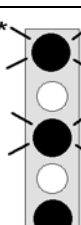
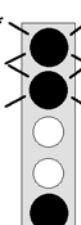
LED Display	HL ***	HyC ***	Message / Mal-function Displayed*	Probable Cause	Resolution
			Fault Max.-Level (ctd.) Unit shuts off automatically.	<ul style="list-style-type: none"> Large amounts of deposits are interfering with and disrupting the blow-down cycle. Due to extra water entering the flushing mechanism, the max.-level is reached during the blow-down process. 	<ul style="list-style-type: none"> Clean humidifier, drain assembly and hose to the control cylinder.
* 	X	X	System failure	<ul style="list-style-type: none"> Mainboard is defective 	<ul style="list-style-type: none"> Check mainboard. If necessary change mainboard
* 	X	X	Fault filling Unit shuts off automatically.	<ul style="list-style-type: none"> Solenoid valve or feed line is fouled or defective. Defective coil. Water supply is not open. Solenoid valve has not been electrically activated. <ul style="list-style-type: none"> The cable connections are faulty. The relay on the main PCB is not operating. The steam hose has not been laid at enough of an incline, causing a water pocket to form. The steam flow is obstructed. For Electrode Steam Humidifiers: <ul style="list-style-type: none"> Phase L3 is missing (external safety fuse is defective). Defective main contactor. 	<ul style="list-style-type: none"> Clean or replace solenoid valve or feed line. Measure coil and replace. Open water supply. Check or replace cable connections. Measure voltage between PCB terminals 11 and 15 (N); replace PCB, if required Check placement of steam hose. Remove water pocket. Replace external safety fuse. Check for fuse blowing reason Replace main contactor.
* 	X		Fault Main Contactor Unit shuts off automatically	<ul style="list-style-type: none"> Main contactor does not drop out. Relay on the PCB is stuck. 	<ul style="list-style-type: none"> Replace main contactor. Replace PCB.

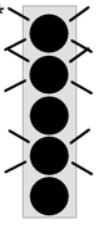
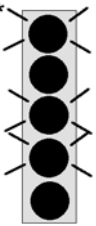
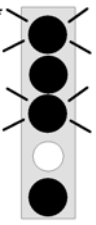
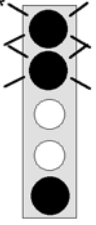
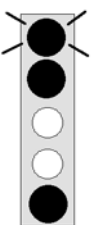
LED Display	HL *** HyC ***	Message / Mal-function Displayed*	Probable Cause	Resolution
	X X	Fault °C sensor Unit shuts off automatically.	<ul style="list-style-type: none"> • Temperature sensor or line defective. • Short circuit in sensor wire (no resistance). 	<ul style="list-style-type: none"> • Check temperature sensor and sensor line, replace if needed. • Replace temperature sensor.
	X	Fault Level sensor Unit shuts off automatically.	<ul style="list-style-type: none"> • Cable connections for the float switch are faulty. • Plug for the float switch is not connected to the control 	<ul style="list-style-type: none"> • Check cable connections, replace if needed. • Connect plug to the control.
	X X	Fault °C Max Unit shuts off automatically.	<ul style="list-style-type: none"> • Heat buildup in the cabin. • Additional heat source in the steam cabin. • Excessive power retention. 	<ul style="list-style-type: none"> • Ensure continuous heat removal. • check Parameter G9.
	X	Fault Activated Thermo Sensor Unit shuts off automatically.	<ul style="list-style-type: none"> • Thermo sensor on the top of the cylinder was activated (HeaterLine = 2 thermo sensors, HeaterCompact = 1 thermo sensor). Heating element is coated by lime. • Thermosensor on the heat sink for the solid state relay has been activated. Openings for chimney are covered. 	<ul style="list-style-type: none"> • Disconnect power supply. Wait until cylinder has cooled down. Press the release pin back down with needle-nose pliers or a screwdriver. Remove lime from heater element. • Press the release pin back down and remove the blocking elements.
	X	Fault steam-down Unit shuts off automatically.	<ul style="list-style-type: none"> • Heater element is defective. • Phase failure. (External breaker has been tripped or is defective.) • Heater element is not supplied with current. • Main contactor is not switching correctly. • PCB does not activate main contactor. 	<ul style="list-style-type: none"> • Measure resistance of the heater element, replace heater element if needed. Heater element resistance at 4.5 kW: approx. 36 Ohm and at 6.75 kW: 24 Ohm • Replace circuit breaker and identify cause. • Check cable connections. Measure voltage. • Check main contactor, replace if needed.. • Measure voltage at PCB terminals 9 against 15. Replace PCB if required.

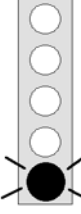
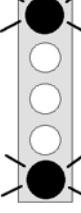
LED Display	HL *** HyC***	Message / Mal-function Displayed*	Probable Cause	Resolution
<p>*</p> 	<p>X</p>	<p>Message Cylinder Full</p>	<ul style="list-style-type: none"> Nominal current or nominal output not reached although cylinder filled up to maximum-limitations electrode. Water input is interrupted. Possible causes: <ul style="list-style-type: none"> - Water conductivity too low. - Cold start - Re-start following full blow-down. - Changing water conductivity. - Electrodes worn out. Unit requires maintenance. <p>No electrode supply cable fed through current</p> <ul style="list-style-type: none"> transducer ring. 	<ul style="list-style-type: none"> Continuous steam production and increasing water conductivity can cause the control lamp to switch off automatically after a period of operation time. nominal output is reached automatically. Check water values and/or contact HygroMatik. Replace electrodes. See maintenance section in this manual. Feed a cable through current transducer ring.
<p>*</p> 	<p>X X</p>	<p>Maintenance interval</p>	<ul style="list-style-type: none"> The maintenance interval has expired. <p>Please note</p> <p>The status of the four upper LED is depending on the momentary operation mode of the humidifier.</p>	<ul style="list-style-type: none"> Service or check steam humidifier. Reset the maintenance interval with parameter P3 "Reset Maintenance Interval". With parameter P2, the maintenance interval can be adjusted to the feed water quality.
		<p>Lost Ground Control</p>	<ul style="list-style-type: none"> Communication between main board and display is disturbed. 	<ul style="list-style-type: none"> Check cable between mainboard and display. Check RS485 interface modules.
<p>*</p> 	<p>X</p>	<p>Maintenance</p> <p>Unit switches off after 60 min. in cylinder full condition.</p>	<ul style="list-style-type: none"> Unit requires maintenance: <ul style="list-style-type: none"> - Cylinder full of scale deposits limiting electrode immersion depth. - Electrodes worn out. Phase missing (external fuse faulty). In case of very low water conductivity, even continuous steam production is not sufficient for raising water conductivity through concentration. 	<ul style="list-style-type: none"> Clean steam cylinder and electrodes; replace electrodes, if required Replace electrodes. (if electrode wear is high, see note in section „Electrode Exchange“ in unit handbook) Replace circuit breaker. Determine water quality; consult HygroMatik, if required.

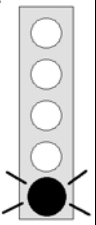
LED Display	HL *** Hy,C***	Message / Mal-function Displayed*	Probable Cause	Resolution
* 	X X	Maintenance K1 System operation continues. Green LED rapidly flashing.	<ul style="list-style-type: none"> According to manufacturer specification 90% of the electrical lifetime is achieved. To avoid failure, a replacement of the main contactor is recommended in the short term. 	<ul style="list-style-type: none"> Replace main contactor. See parameter description "P11 reset main contactor interval" for Comfort / Comfort Plus control or "Brief Description of Jumpers" for Basic control.
	X X	Safety stop	<ul style="list-style-type: none"> Parameter D5 for limitation of operating time is activated. Steam generator stopped operation after the safety interlock was closed for the time set in parameter D5. 	<ul style="list-style-type: none"> By opening and closing the safety interlock the steam generator restarts operation for the number of hours programmed in D5. Alternatively, set D = 0 and restart system. Function „Operating time limitation“ is now deactivated.

HL *** Hy,C***	Possible Conditions	Probable Cause	Resolution
X X	Water is collecting on the base plate	<ul style="list-style-type: none"> Cylinder improperly assembled after maintenance: <ul style="list-style-type: none"> -O-Ring has been damaged, has not been replaced, or has not been inserted - Flange (slot / spring) is damaged - Flange has not been sealed properly - Mineral deposits in the flange. The cylinder is incorrectly placed on the base. The water cannot drain away during flushing. 	<ul style="list-style-type: none"> Clean cylinder and install properly. Lay a moistened new o-ring in the base and then insert the cylinder. Make sure drain is unobstructed.
X X	Water is leaking from upper part of steam cylinder.	<ul style="list-style-type: none"> Hose clamps on the steam or condensate hose do not close tightly. The heater element or thermo sensor has not been properly installed. Steam hose adapter has not been correctly installed or o-ring has not been changed. If condensate is not into the steam cylinder, the condensate connection must have a condensate plug. 	<ul style="list-style-type: none"> Tighten hose clamps. Install heater element and thermo sensor as specified in the manual. Replace o-ring and correctly install steam hose adapter. Install condensate plug.

HL *** Hy,C***	Possible Conditions	Probable Cause	Resolution
X X	<p>No steam production, even though the steam generator has been activated. The display is active.</p> <p>Please note Performing a signal test and a steam requirement test may give additional information about the cause of the malfunction. See Section System Test.</p>	<ul style="list-style-type: none"> • If the temperature exceeds the set desired value, no steam demand is present. • The unit has been switched off remotely. (Terminals 1 and 2 in the steam generator are not bridged.) • Poor air circulation, steam bath temperature has remained above the programmed set value for a long period of time. 	<ul style="list-style-type: none"> • Check desired and actual temperature values. • Switch on the unit using the remote switch, or install a jumper between terminals 1 and 2. • Install a fan.
X	<p>No steam production. Current is supplied to the electrodes, but no water is being fed.</p>	<ul style="list-style-type: none"> • Water supply is not open or solenoid valve has not been electrically triggered. 	<ul style="list-style-type: none"> • Open water supply. • Also see Fault Filling.
X X	<p>The set temperature has not been reached.</p>	<ul style="list-style-type: none"> • The unit's steam generation output limitation prevents full output. • The unit is being operated at "cylinder full" (only with electrode steam humidifiers). • Incorrect output estimate. • Phase failure (external fuse). 	<ul style="list-style-type: none"> • Check steam generation output limitation parameter "P1". • See message Maintenance / Cylinder Full • Check output data, steam bath insulation and dimensions. • Replace fuse.
X X	<p>No visible steam in the cabin.</p>	<ul style="list-style-type: none"> • Steam bath is too well insulated. • Insufficient air circulation in the steam bath • Excessive heat supply (i.e. from heated benches) 	<ul style="list-style-type: none"> • Provide for heat removal. • Check exhaust fan performance; install fan • Reduce additional heat supply
X X	<p>Temperature is too high</p>	<ul style="list-style-type: none"> • Temperature sensor has not been correctly calibrated. 	<ul style="list-style-type: none"> • Check Parameter "Adjustment Actual Temperature Value" (G0)
X X	<p>Essence delivery into the steam bath is absent or insufficient</p>	<ul style="list-style-type: none"> • No essence in reservoir • Essence injector has not been activated. • Essence delivery duration is too short. • Essence delivery interval is too long. • Fuse or relay in the control for essence delivery is faulty (when employing 24 V). • Tube in peristaltic pump is defective (essence flows back into the essence reservoir). 	<ul style="list-style-type: none"> • Replenish essence • Activate essence injector. (Check power supply to the essence solenoid valve and peristaltic pump.) • Increase essence delivery duration. • Shorten essence delivery interval. • Replace fuse. (Check power supply to the essence solenoid valve.) • Replace tube into peristaltic pump.

HL *** HyC***	Possible Conditions	Probable Cause	Resolution
X X	Excessive essence delivery into the steam bath	<ul style="list-style-type: none"> • Essence delivery duration is too long • Essence delivery interval is too short. 	<ul style="list-style-type: none"> • Reduce essence delivery duration. • Lengthen essence delivery interval.
X X	No steam production even though the steam generator is on. The display is dark	<ul style="list-style-type: none"> • Defective fuse F1 (1.6 A) • Phase failure L3. (External breaker has been tripped or is defective.) 	<ul style="list-style-type: none"> • Check micro fuse and replace, s. also „Wiring Diagram“ section. • Replace external breaker and investigate possible causes.
X X	Blow-down pump is working, but no water is being flushed	<ul style="list-style-type: none"> • Cylinder base or blow-down system is blocked. 	<ul style="list-style-type: none"> • Clean cylinder base or blow-down system.
X X	Cylinder has completely drained after a blow-down, even though pump is switched off.	<ul style="list-style-type: none"> • Vent pipe is blocked. 	<ul style="list-style-type: none"> • Clean or replace vent tube. Replace vent pipe adapter. Also see unit manual.
X X	No steam is exiting the steam manifold. Water leaks periodically from the drain hose while the pump is not running.	<ul style="list-style-type: none"> • false steam direction installation (waterbag) • Excess pressure in duct system (max. overpressure 1200Pa/0.174psi) 	<ul style="list-style-type: none"> • Lay steam hose as specified in Section “types of installation“ in the unit manual. • Lengthen drain hose, consult with HygroMatik if necessary.
X	Uneven electrode wear	<ul style="list-style-type: none"> • Electrode(s) is/are not supplied with power. Breaker has been tripped. • Main contactor does not operate. • Uneven working load • Uneven immersion depth of electrodes. The unit has not been mounted plumb and level. 	<ul style="list-style-type: none"> • Check breaker, replace if necessary • Check main contactor, replace if required • Check power supply (measure voltage differential.) • Check for plumb and level mounting; make correction, if required

HL *** Hy,C***	Possible Conditions	Probable Cause	Resolution
	<p>X Light / sparks in the cylinder</p>	<ul style="list-style-type: none"> The appearance of light or sparks suggests rapid loss of electrode material (brown-black deposits) and very high water conductivity. <p>In these cases, consult HygroMatik.</p> <ul style="list-style-type: none"> Blow-down pump is not working properly or is defective. 	<ul style="list-style-type: none"> Deactivate the unit immediately to prevent it from being damaged. <p>Perform maintenance:</p> <ul style="list-style-type: none"> Replace electrodes Clean steam cylinder Check water quality or conductivity, also see Section „Directions for Use“. Increase blow-down frequency and/or blow-down volume. <ul style="list-style-type: none"> Check blow-down pump function and replace blow-down pump if necessary. See message Blow-Down Fault

* :

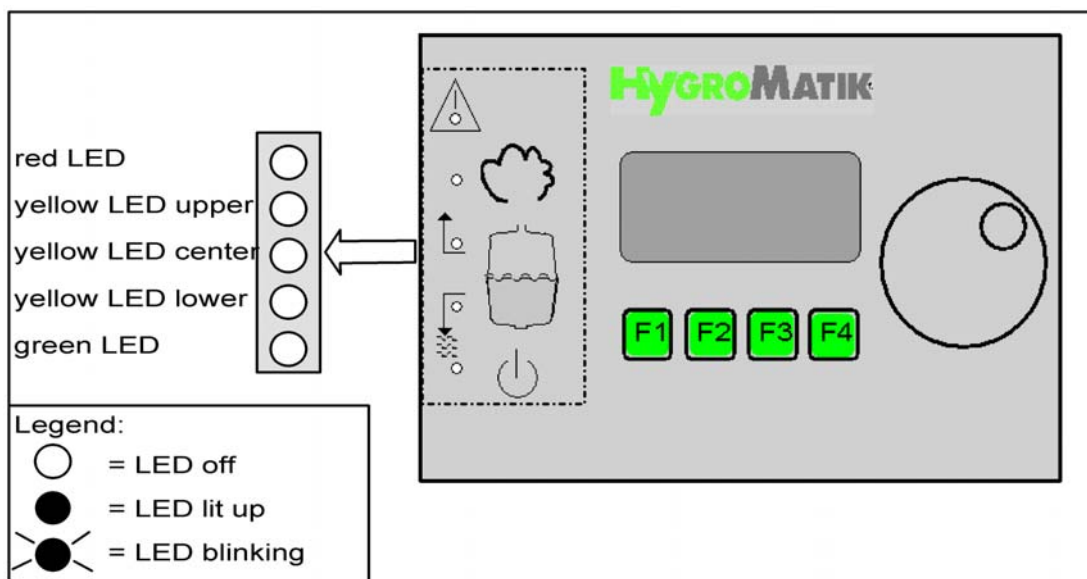

** Only Comfort- DS / Comfort Plus- DS

*** Hy, C = Electrode Steam Generator, HL = Heater Element Steam Generator

13. Basic PCB Connections

Main PCB

B3	transducer (only Humidifier type HyLine, CompactLine and MiniSteam)
D6	fault indicator lamp (red)
D64	humidify indicator lamp (yellow)
D 63	filling indicator lamp (yellow)
D62	blow-down indicator lamp (yellow)
D61	operating indicator lamp (green)
P1	potentiometer steam generation output limitation; 25 - 100% humidification output
P2	potentiometer pump run time 0 - 45 sec.
6 - 7	sensor electrode input (ST2)
9	main contactor output (ST1)
10	pump output (ST1)
11	solenoid valve output (ST1)
15 - 16	main PCB power supply (ST1) 24V AC*/ 230VAC* *: depending on the control voltage
16	blow-down pump power supply (ST1)
19,17,18	semiconductor relay (ST5) (only Humidifier type Heater-Line)
21 - 24	level switch (ST6) (only Humidifier type HeaterLine)
28 - 30	signal relay (collective fault) (ST4)
31 - 42	4 signal relay outputs (installed on JP3)
JP1	(not used)
ST 8	COM-Port jack
ST 9	remote control jack
JP 9 / JP 4	jumper socket interface driver
JP 5	jumper socket display
JP 3	base socket signal relay PCB
4 - 42	temperature sensor (ST3)
3	24 V DC
2	Input remote switch / safety interlock

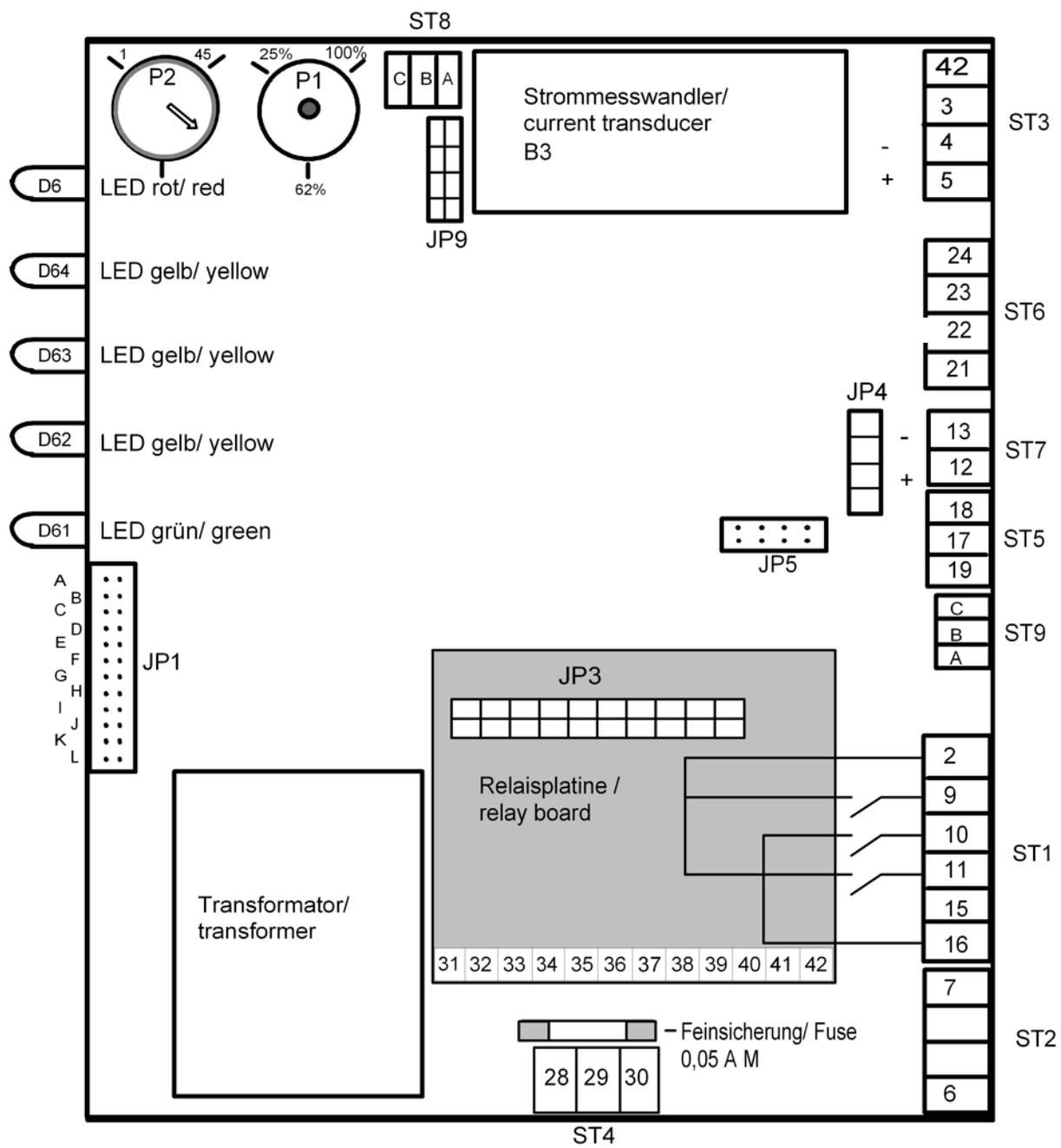

0.5 A M

14. Terminal Assignments on the Unit Connector Strip and Wiring Diagram Legend

Unit Connector Strip:

Terminals	Assignment
1 / 2	Remote Switch / Safety Interlock
6 / 7	Temperature Sensor
8 / 9 / 13	Essence Injector max. 70 W / 24 V / 3.15 A
10 / 11	Exhaust Fan max. 40 W / 24 V / 1.6 A
10 / 12	Supply Fan max. 40 W / 24 V / 1.6 A
14 / 15	Light max. 40 W / 24 V / 1.6 A

Wiring Diagram Legend:

Designation	Specification
B1	Max.-Water Level Electrode
B3	Transducer
F1 and F2	Fuses transformer (T1) 0.5 A or 1.0 A
F3 and F4	Fuses control 5.0 A
F5	Fuse transformer (T2, sensor electrode)
F7 and F8	Fuses transformer (T2, steam bath option) 0.5 A or 1.0 A
F9 and F10	Fuses 5.0 A
F13	Essence Injector Fuse 2.5 A
F14	Exhaust Fan Fuse 1.6 A
F15	Supply Fan Fuse 1.6 A
F16	Light Fuse 1.6 A
K1	Main Contactor
L1 - L3	Main Terminals
M1	Blow-Down Pump
N	Neutral
PE	Grounding Terminal
S1	Control Switch ON (I) / OFF (0), pumping (II)
X1	Connector Strip
Y1	Solenoid Valve
Y2	SUPER FLUSH (optional)

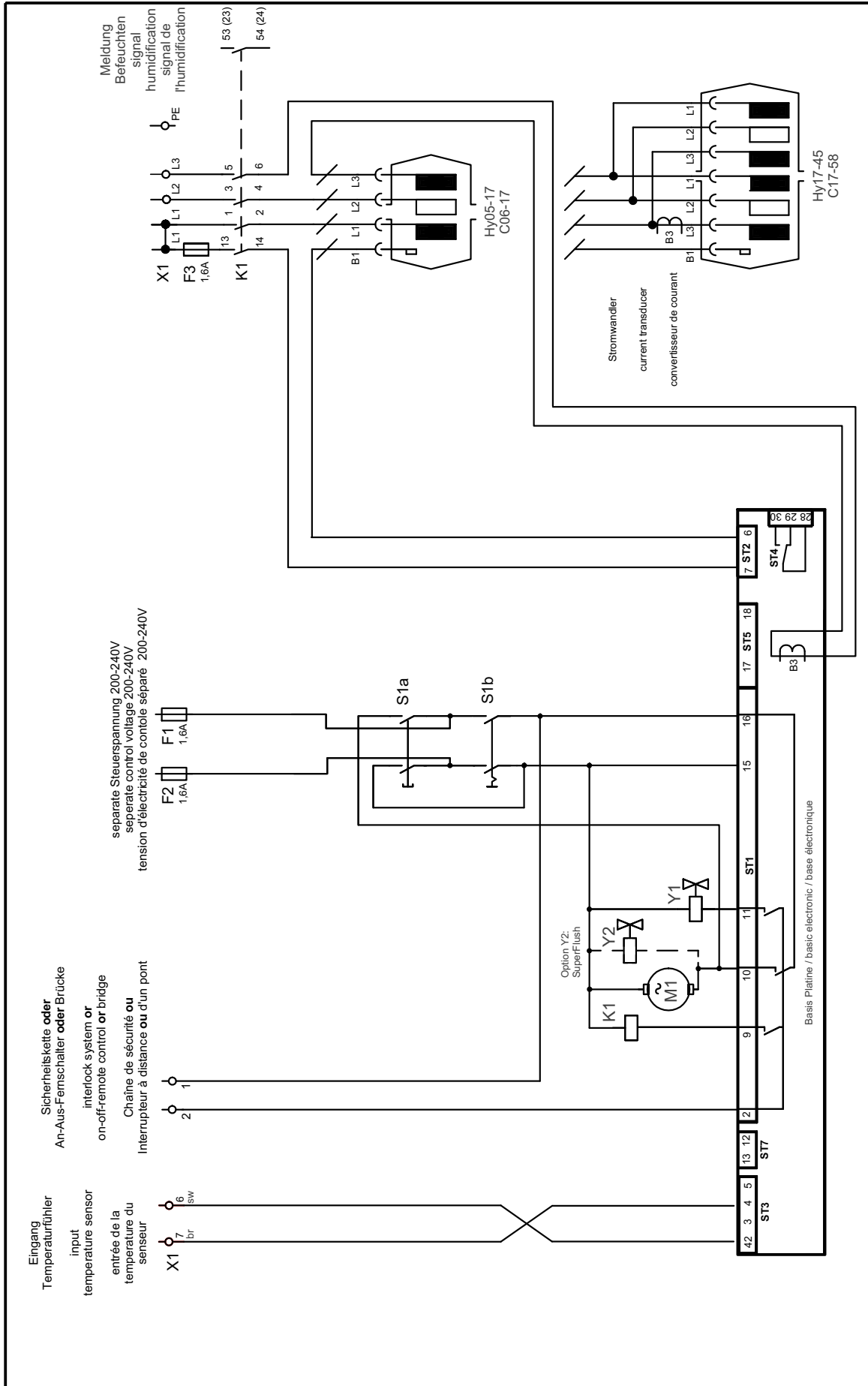

a	release	23.07.15	WI	Date	07.07.15	(Description)	Hy05-45; C01-58	HYGROMATIK	Phone	+49-(0)4193 / 895 - 0
b	text eng.	31.08.15	WI	User	WI	BDS, CDS, CPDS	200-480V/3/50-60Hz UL/CSA	Lise-Meiner-Str. 3	Telefax	+49-(0)4193 / 895 - 33
	Changes			checked		separate Steuerspannung / control voltage 200-240V		D-24558 Henstedt-Ulzburg	(File)	S-31-001B.002
Status			Name	Norm	Origin:			Germany		Blatt 2
										vom 3
										Bl.

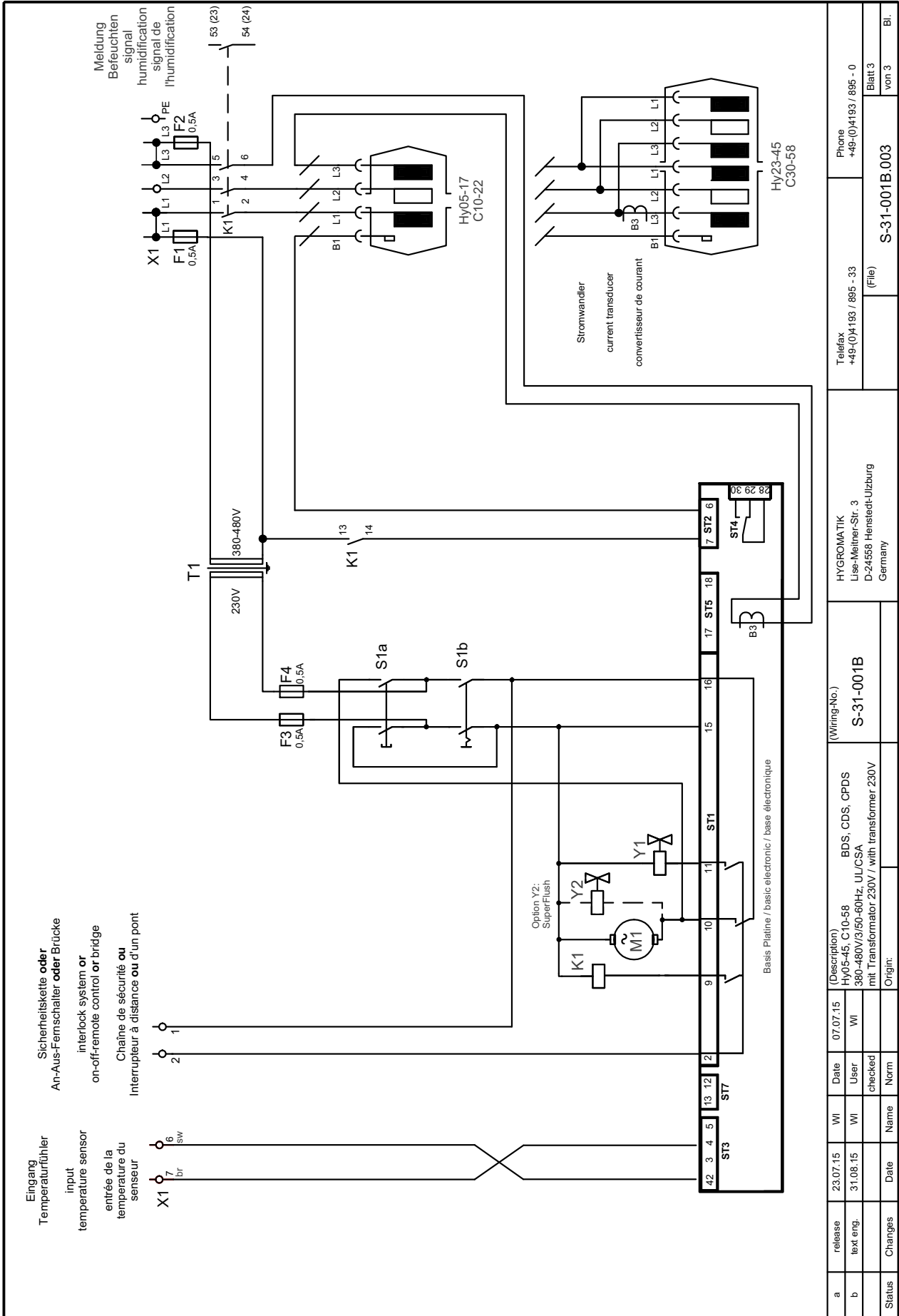

a	release	23.07.15	WI	Date	07.07.15	(Description)	HYGROMATIK	Telefax	Phone
b	text eng.	31.08.15	WI	User	WI	Hy05-45, C10-58 380-480V/3/50-60Hz, UI/CSA mit Transformator 230V / with transformer 230V	Lise-Meiner-Str. 3 D-24556 Henstedt-Ulzburg Germany	+49-(0)4193 / 895 - 33 (File)	+49-(0)4193 / 895 - 0
Status	Changes	Date	Name	Norm	checked	Origin:			Blatt 3 von 3
							S-31-001B	S-31-001B_003	

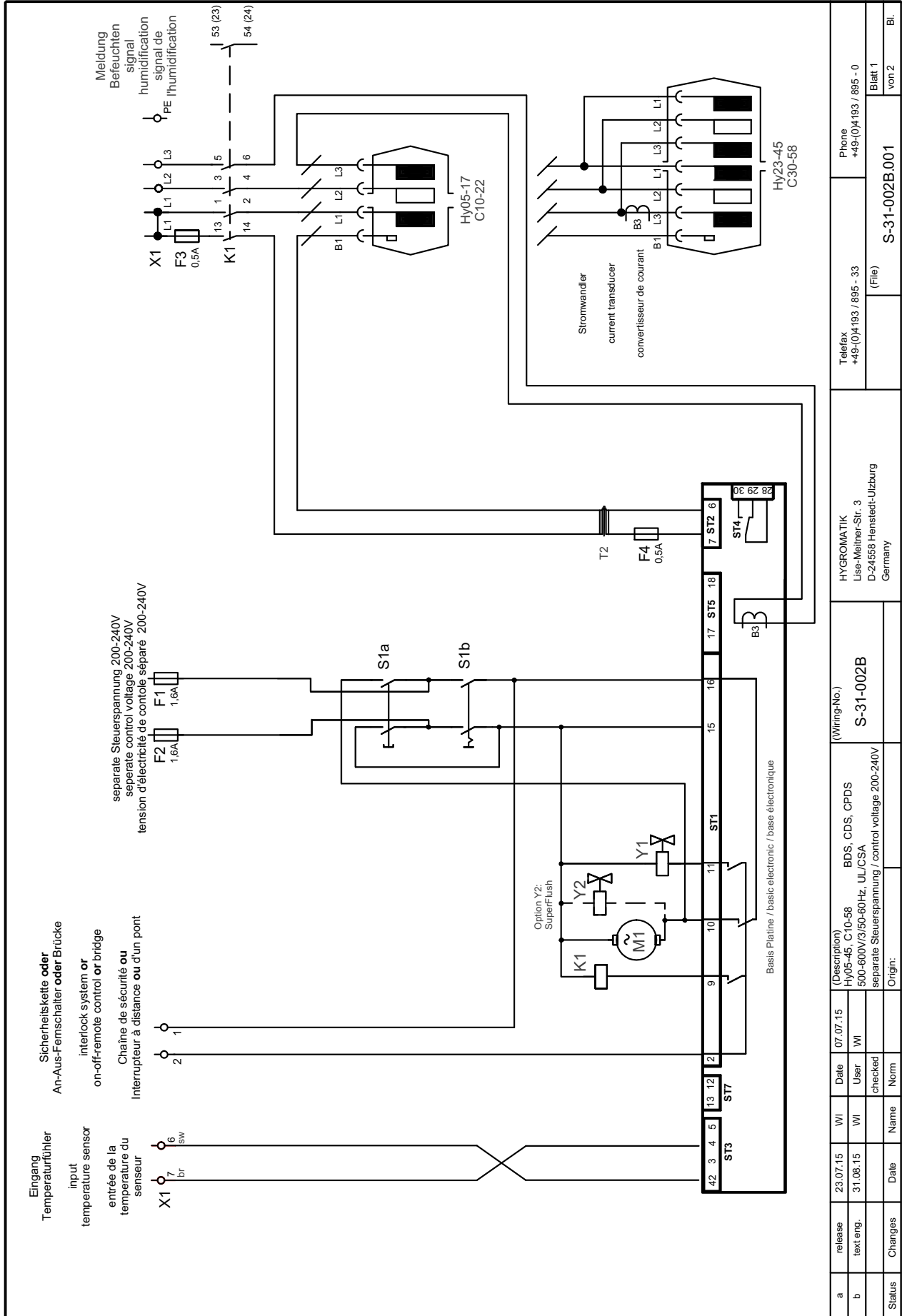

a	release	23.07.15	WI	Date	07.07.15	(Description)	HYGROMATIK	Telefax	Phone
b	text eng.	31.08.15	WI	User	WI	Hy05-45, C10-58 500-600V/3/50-60Hz, UL/CSA separate Steuerspannung / control voltage 200-240V	Lise-Meiner-Str. 3 D-24558 Hensted-Ulzburg Germany	+49-(0)4193 / 895 - 33	+49-(0)4193 / 895 - 0
Status	Changes	Date	Name	Norm	checked	Origin:		(File)	Blatt 1
								S-31-002B.001	von 2
									Bl.

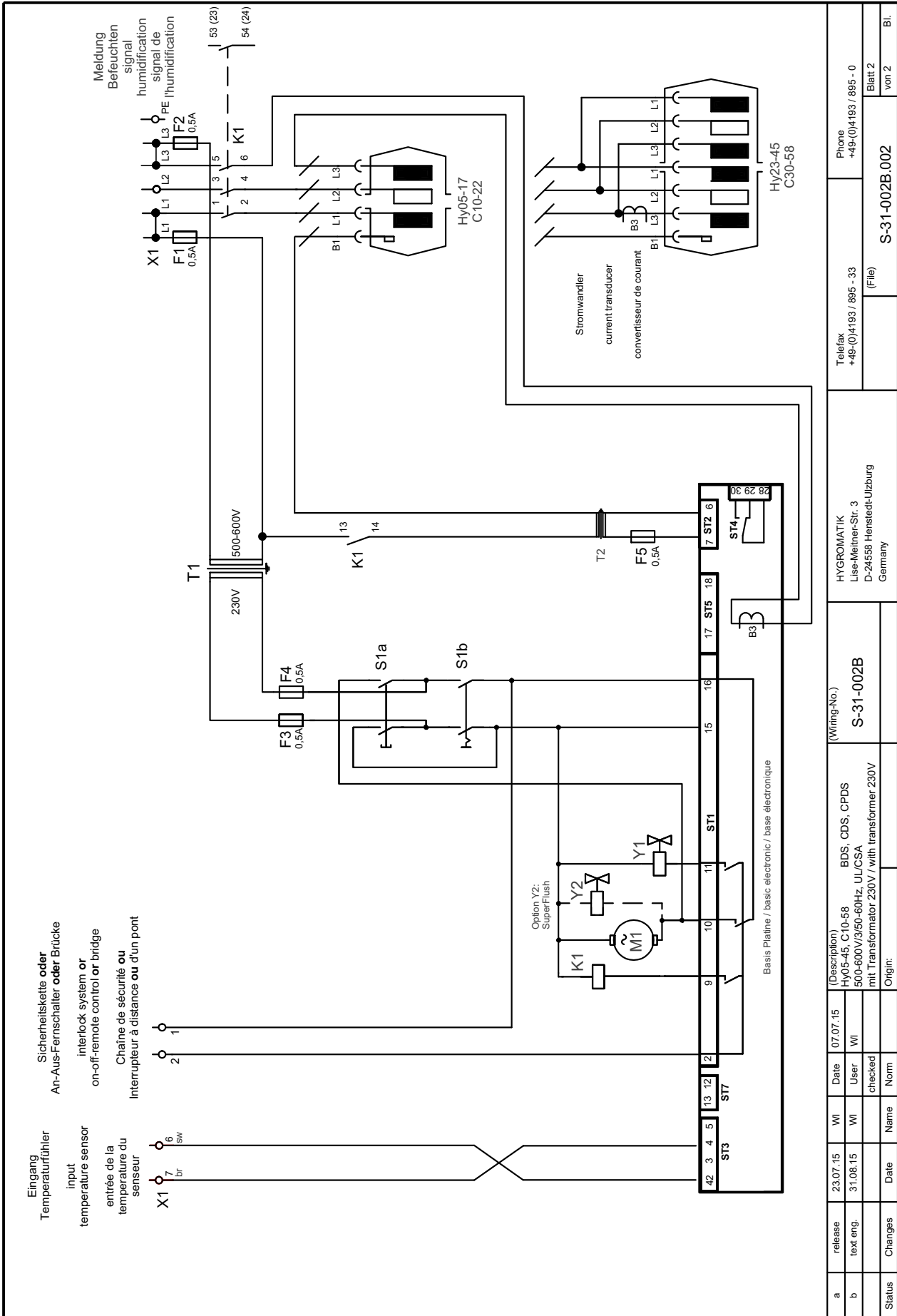

a	release	23.07.15	WI	Date	07.07.15	(Description)	HYGROMATIK Lise-Meiner-Str. 3 D-24558 Henstedt-Utzburg Germany	Telephone +49-(0)4193 / 895 - 33 (File)	Phone +49-(0)4193 / 895 - 0
b	text eng.	31.08.15	WI	User	WI	Hy05-45, C10-58 500-600V/3/50-60HZ, UL/CSA int Transformer 230V / with transformer 230V			
Status		Changes	Date	Name	Norm	Origin:			
							(Wiring-No.)	S-31-002B	
								S-31-002B.002	
								Blatt 2 von 2	

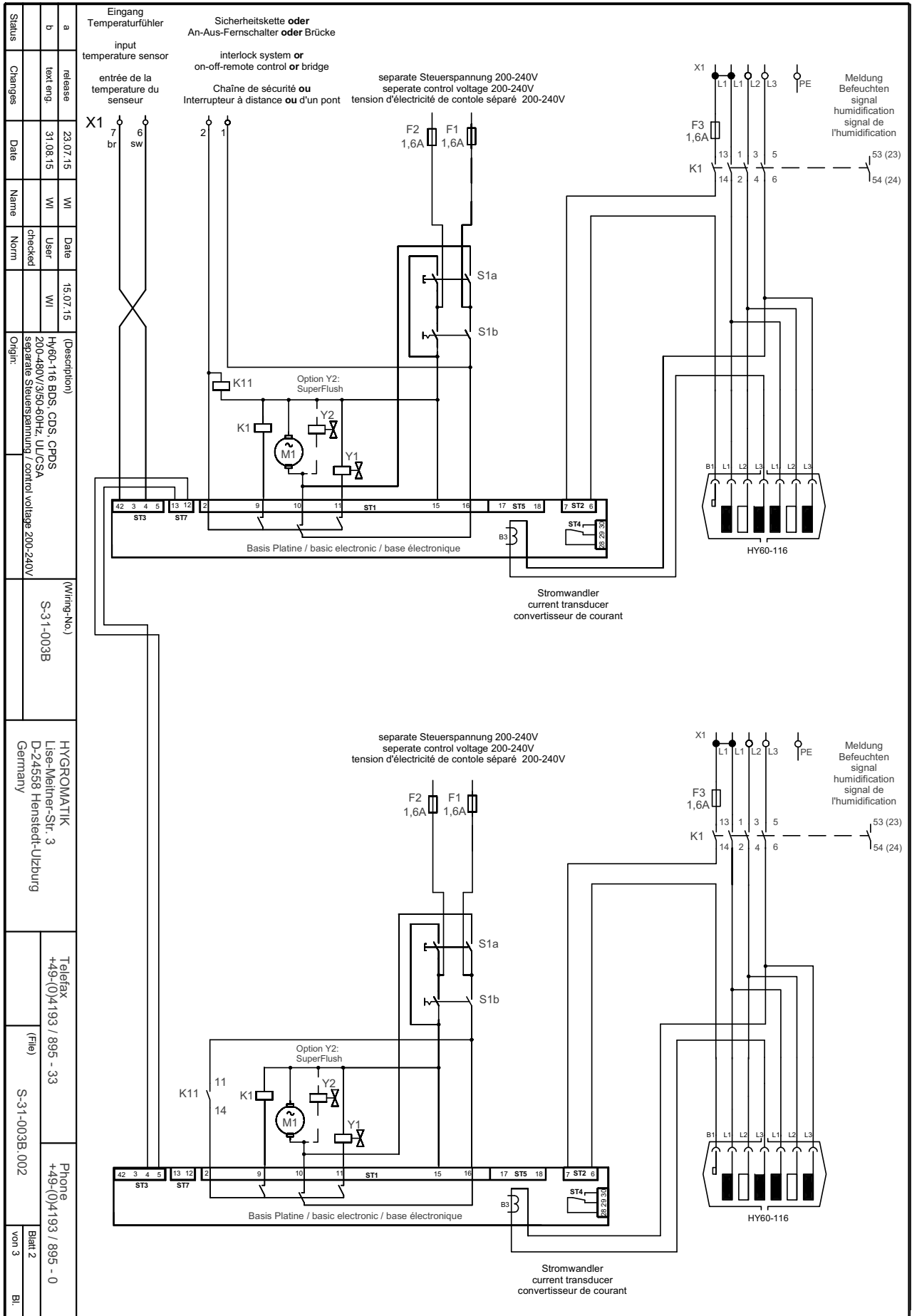

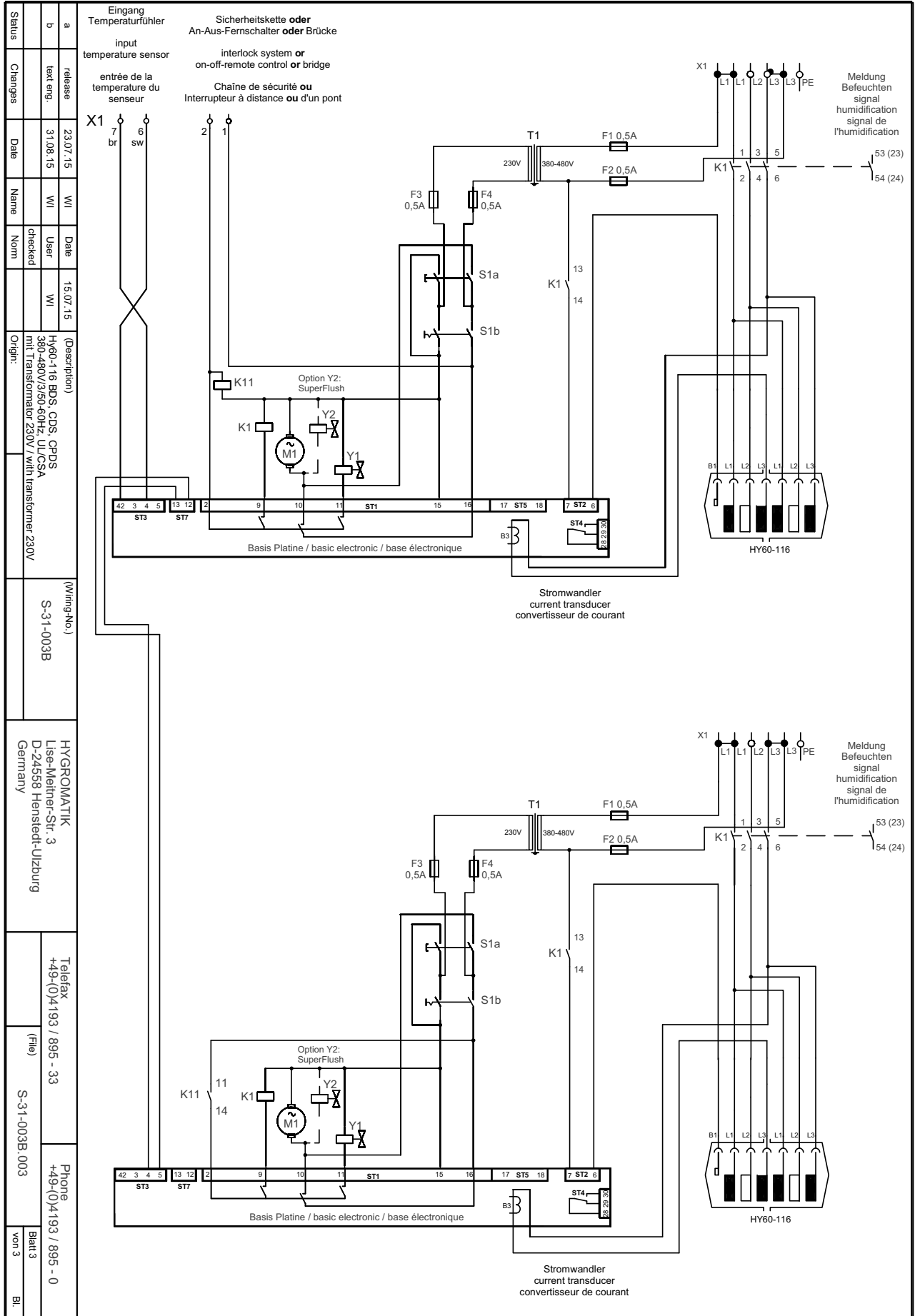

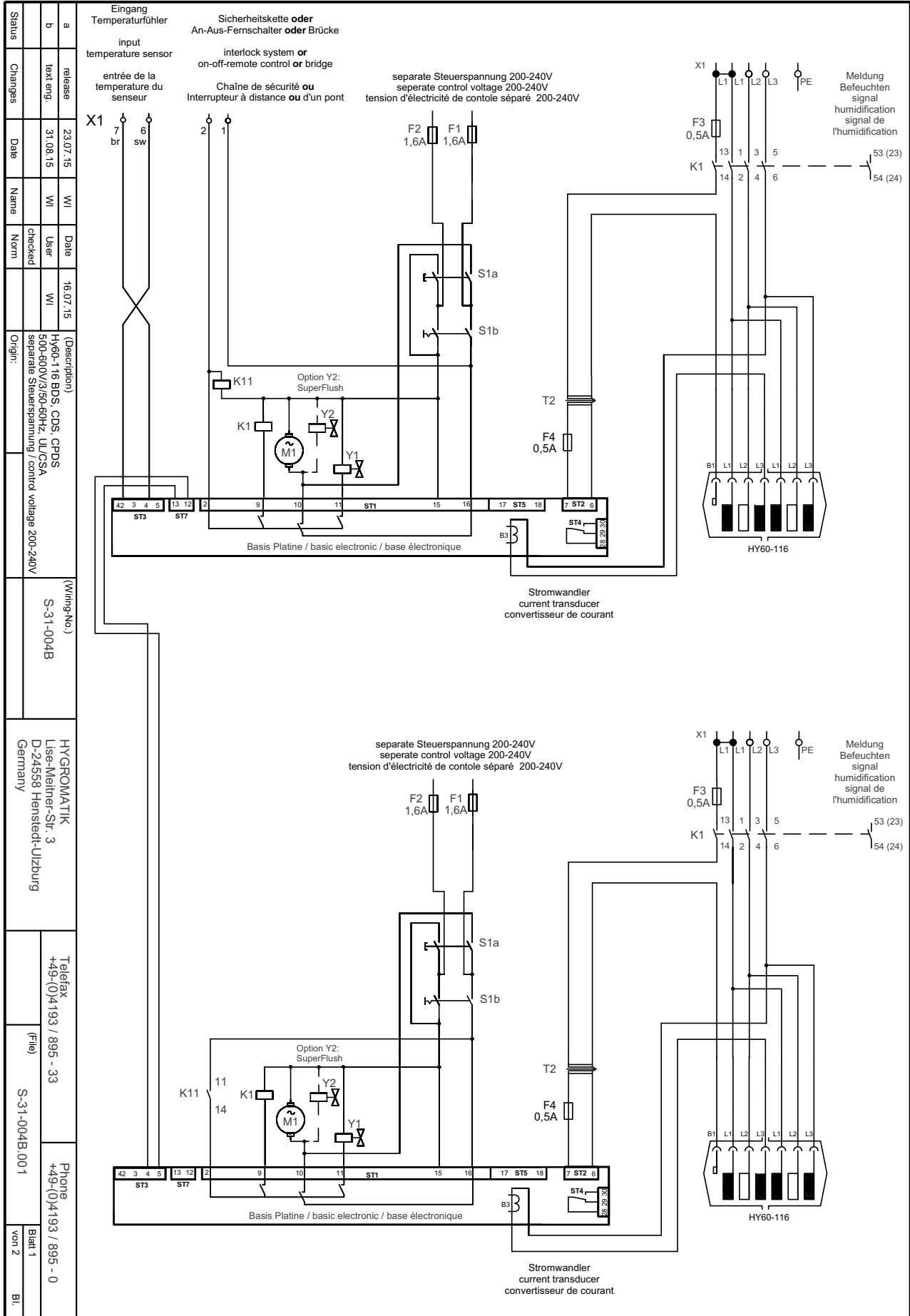

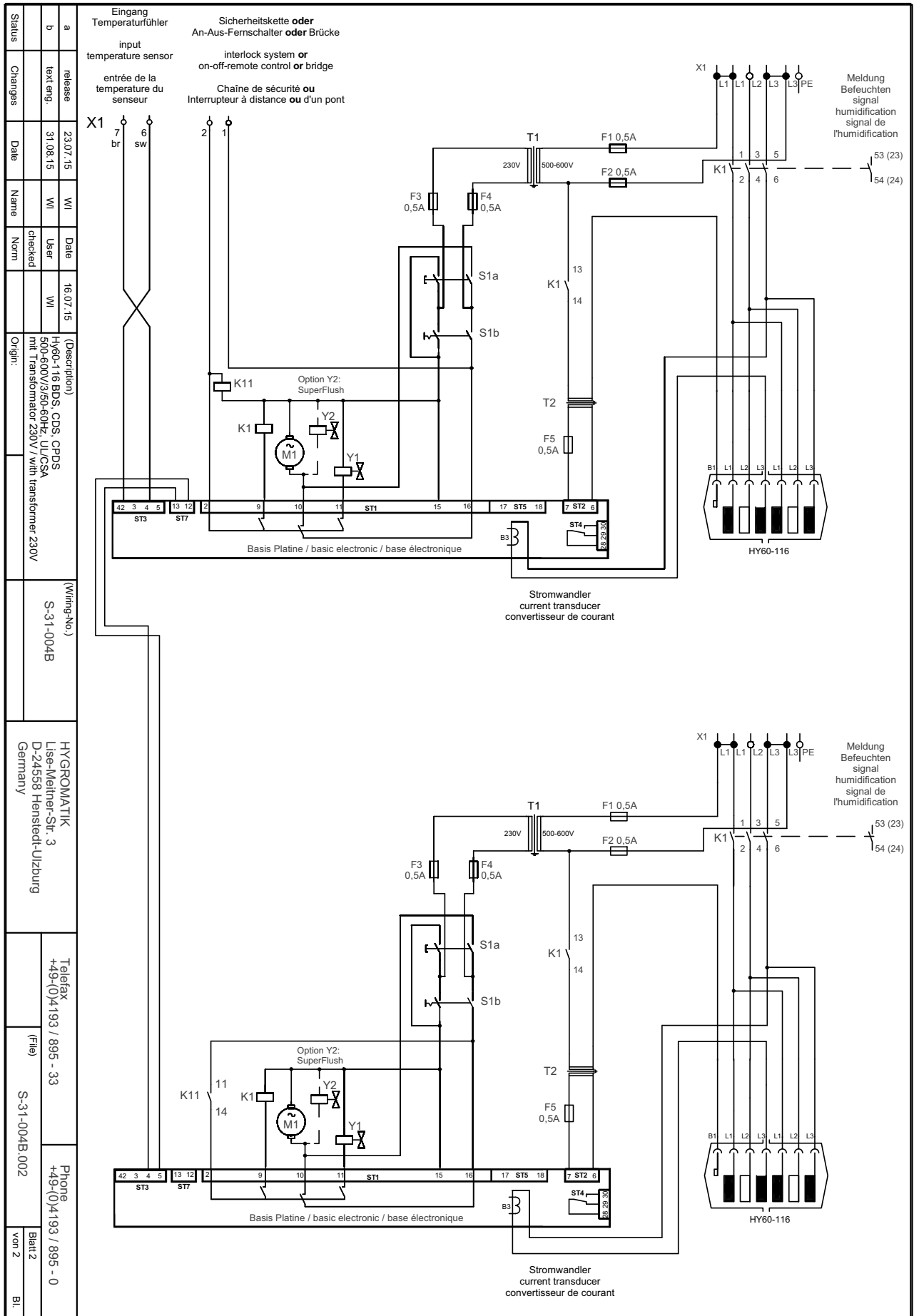

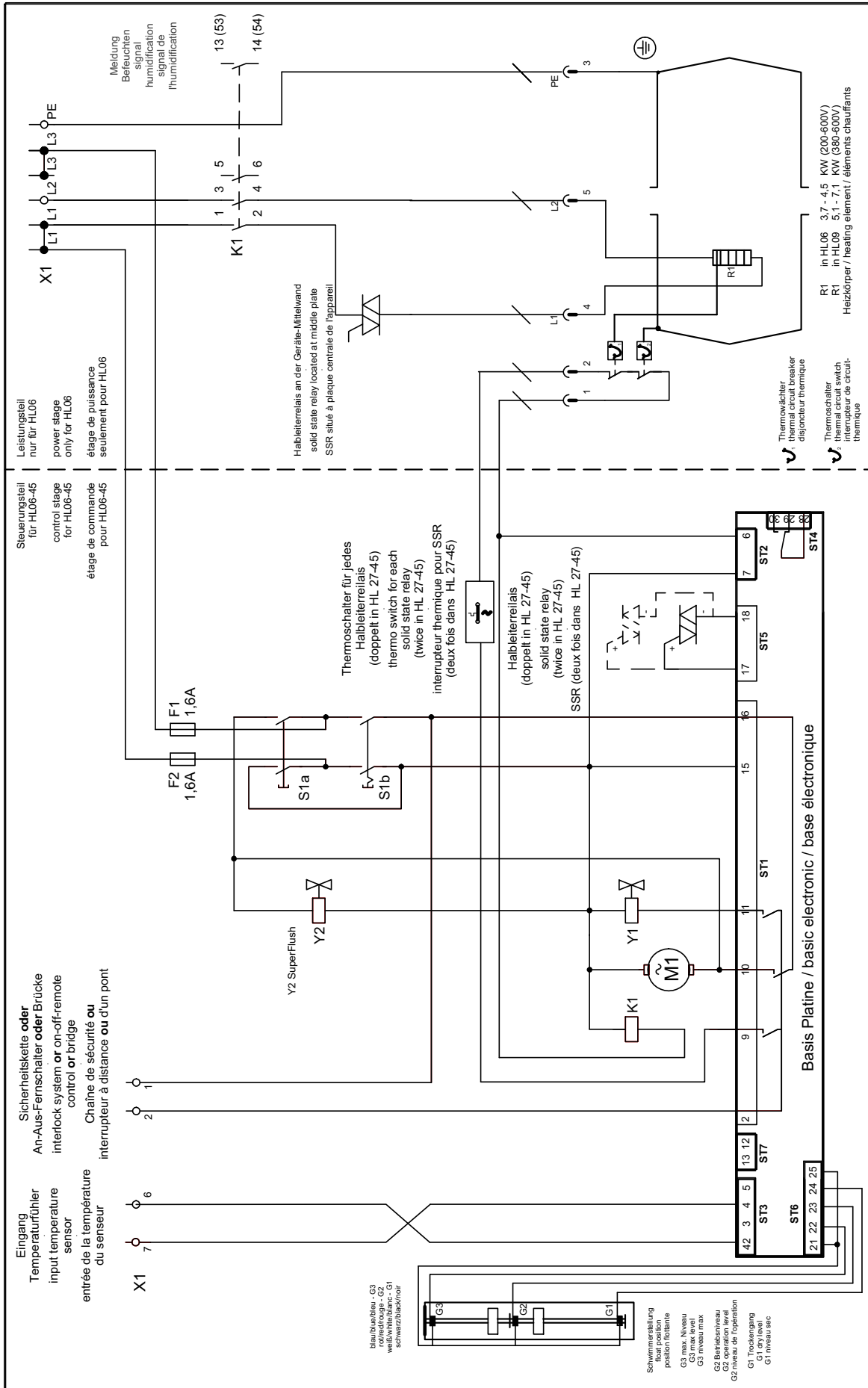

a	release	27.07.15	Lue	Date	27.07.15	(Description)	HL 06 - 24 200-240/50HZ-ULCSA - BDS, CDS, CPDS	HYGROMATIK Lise-Meliner-Str. 3 D-24558 Henstedt-Ulzburg Germany	Telephone +49-(0)4193 / 895 - 33	Phone +49-(0)4193 / 895 - 0
b	G1 & TW	21.08.15	WI	User	Lue	for HL 12 - 24: power stack S-28-001B.004	(Wiring-No.) S-29-001B		(File)	S-29-001B.001
c	Changes		Name	Norm	checked					Page 1 of 5

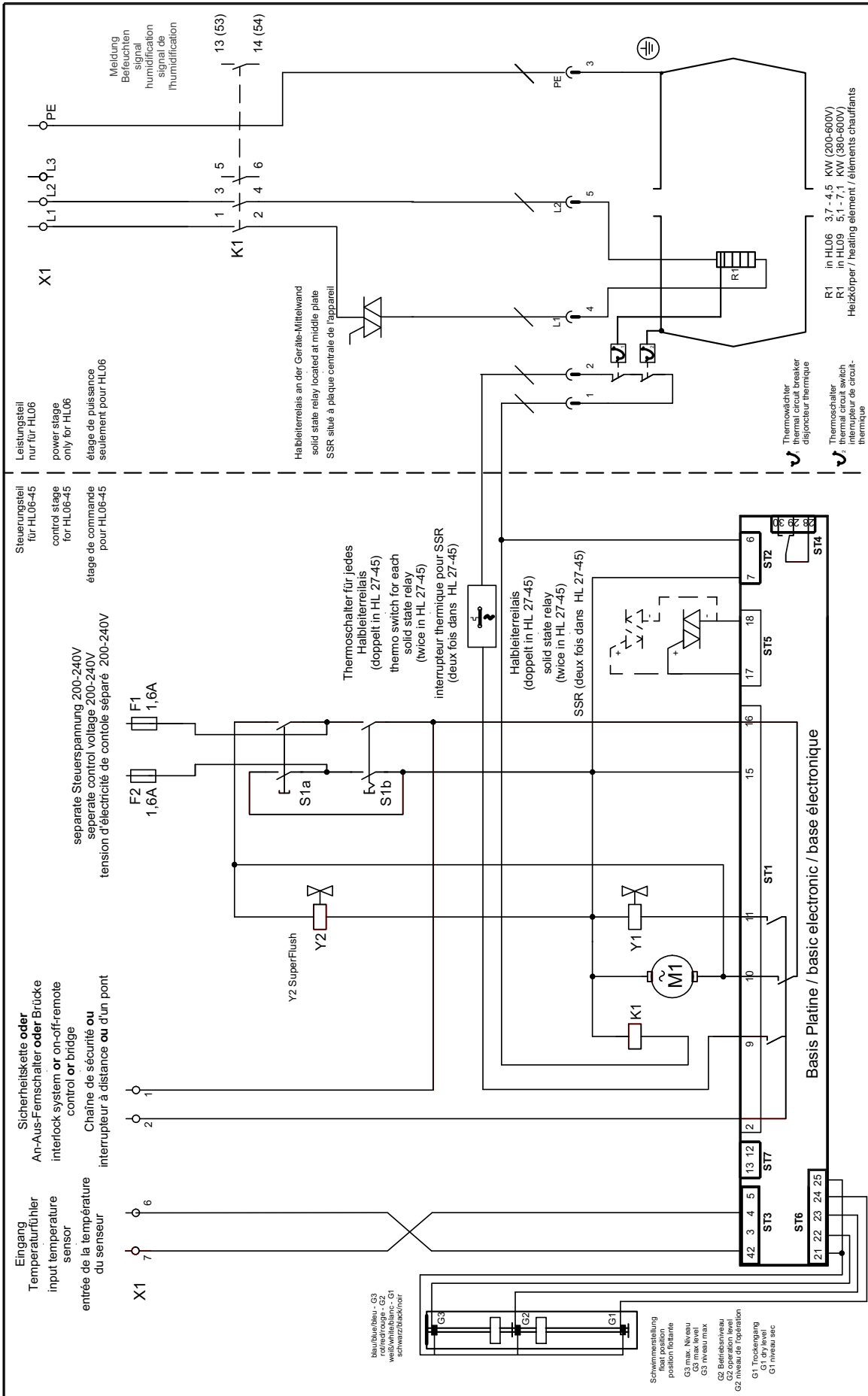

a	release	27.07.15	Lue	Date	27.07.15	(Description)	HL06-45 380-600V/50Hz UL/GSA - BDS, CDS, CPDS	HYGROMATIK	Telephone	+49-(0)4193 / 895 - 0
b	G1 & TW	21.08.15	WI	User	Lue	separate Steuerung / sep. control voltage	for HL12-45; power stack S-28-001B.005	Lise-Meliner-Str. 3	Telefax	+49-(0)4193 / 895 - 33
c				checked				Germany	(File)	S-29-001B.002
Status	Changes	Date	Name	Norm	Origin:					Page 2 of 5

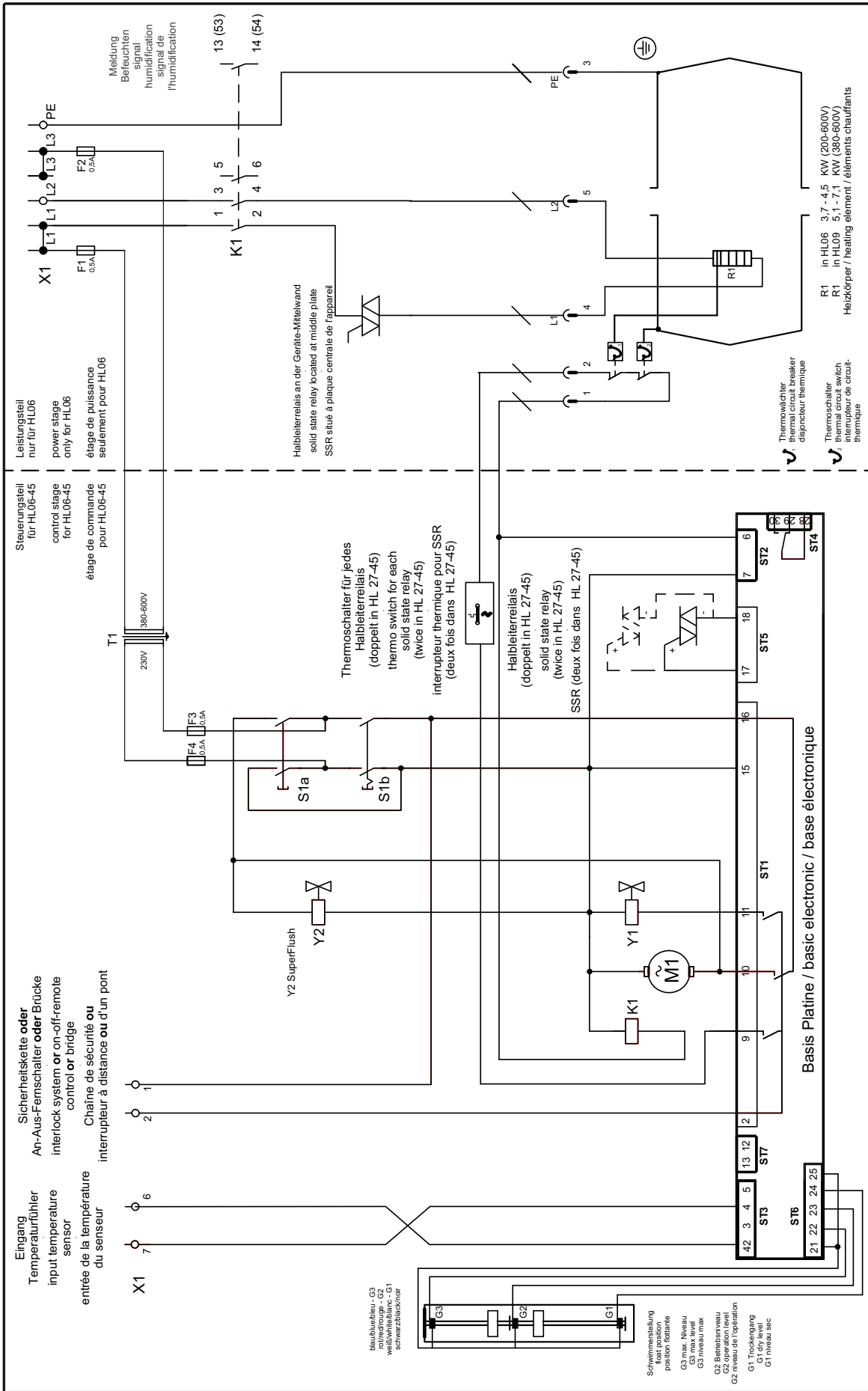

a	release	27.07.15	Lue	Date	27.07.15	(Description)	HL 06 - 45 380-600/350Hz UL/CSA - BDS, CDS, CPDS	HYGROMATIK	Telephone	+49-(0)4193 / 895 - 33	Phone	+49-(0)4193 / 895 - 0
b	G1 & TW	21.08.15	Wli	User	Lue	Transformer / transformator - 230V for HL 12 - 45; power stack S-28-001B.005	D-24158 Henstedt-Ulzburg	(File)	S-29-001B.003	Page 3	of 5	
c	Changes		Name	Norm	checked	Origin:	Germany					
Status			Date	Name	Norm	checked	Germany					

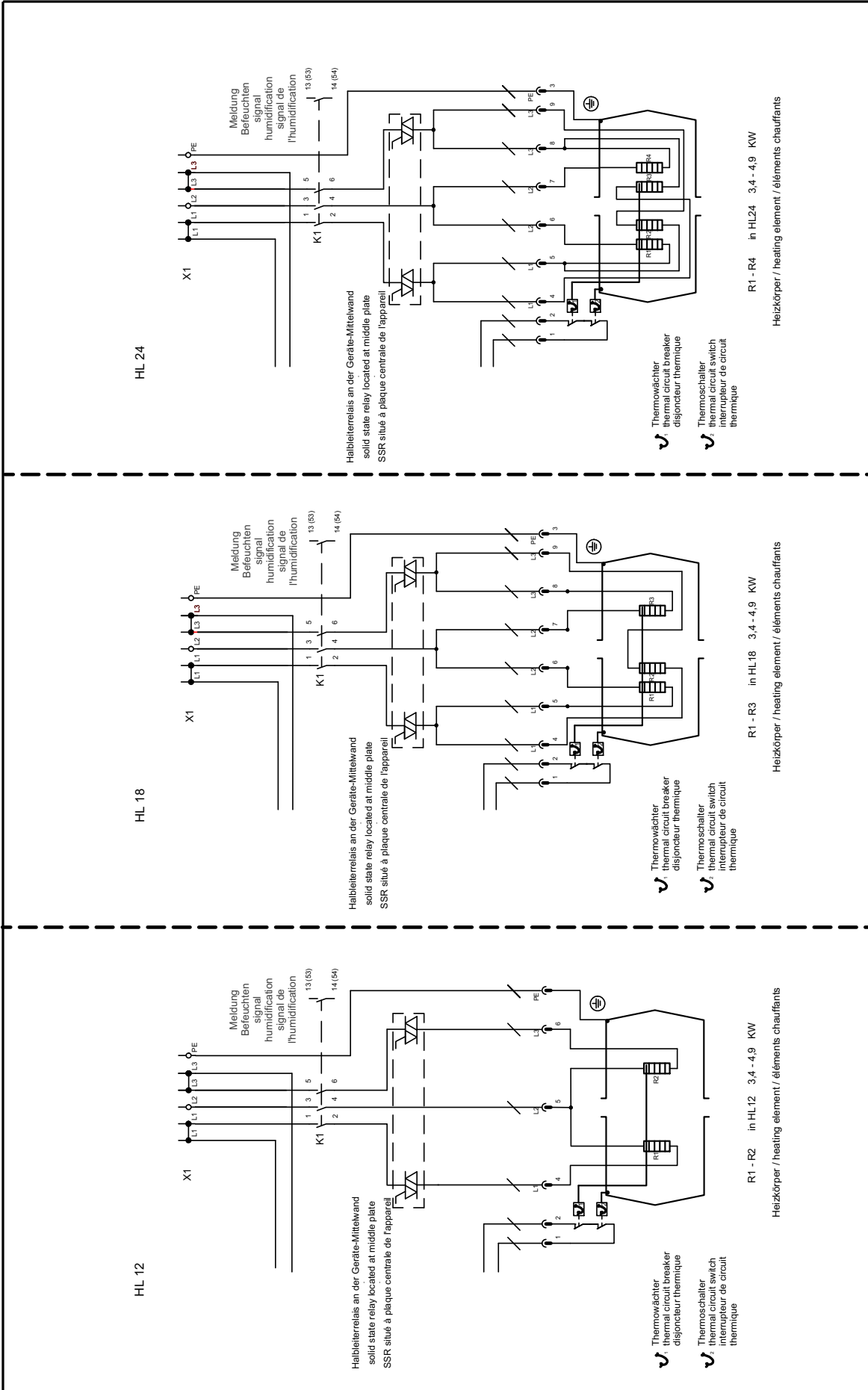

HL 24

HL 18

HL 12

Thermowächter thermal circuit breaker disjoncteur thermique		Thermoschalter thermal circuit switch interrupteur de circuit thermique		R1 - R4 in HL24 3,4 - 4,9 KW Heizkörper / heating element / éléments chauffants	
Thermowächter thermal circuit breaker disjoncteur thermique		Thermoschalter thermal circuit switch interrupteur de circuit thermique		R1 - R3 in HL18 3,4 - 4,9 KW Heizkörper / heating element / éléments chauffants	
Thermowächter thermal circuit breaker disjoncteur thermique		Thermoschalter thermal circuit switch interrupteur de circuit thermique		R1 - R2 in HL12 3,4 - 4,9 KW Heizkörper / heating element / éléments chauffants	
Halbleiterteils an der Geräte-Mittelwand solid state relay located at middle plate SSR situé à plaque centrale de l'appareil		Halbleiterteils an der Geräte-Mittelwand solid state relay located at middle plate SSR situé à plaque centrale de l'appareil		Halbleiterteils an der Geräte-Mittelwand solid state relay located at middle plate SSR situé à plaque centrale de l'appareil	
Meldung Befeuerten humidification signal de l'humidification		Meldung Befeuerten humidification signal de l'humidification		Meldung Befeuerten humidification signal de l'humidification	
Meldfax +49-(0)4193 / 895 - 33 (File)		HYGROMATIK Lise-Meiner-Str. 3 D-24558 Hensel-Utzburg Germany		Phone +49-(0)4193 / 895 - 0	
S-28-001B		(Wiring-No.) S-28-001B		S-28-001B.004	
power stack HL12-24 200-240V/3/50-60Hz		Origin:		Page 4 of 5	
a	release	27.07.15	Lue	27.07.15	(Description)
b	TW	21.08.15	WI	Lue	
c				checked	
Status	Changes	Date	Name	Norm	

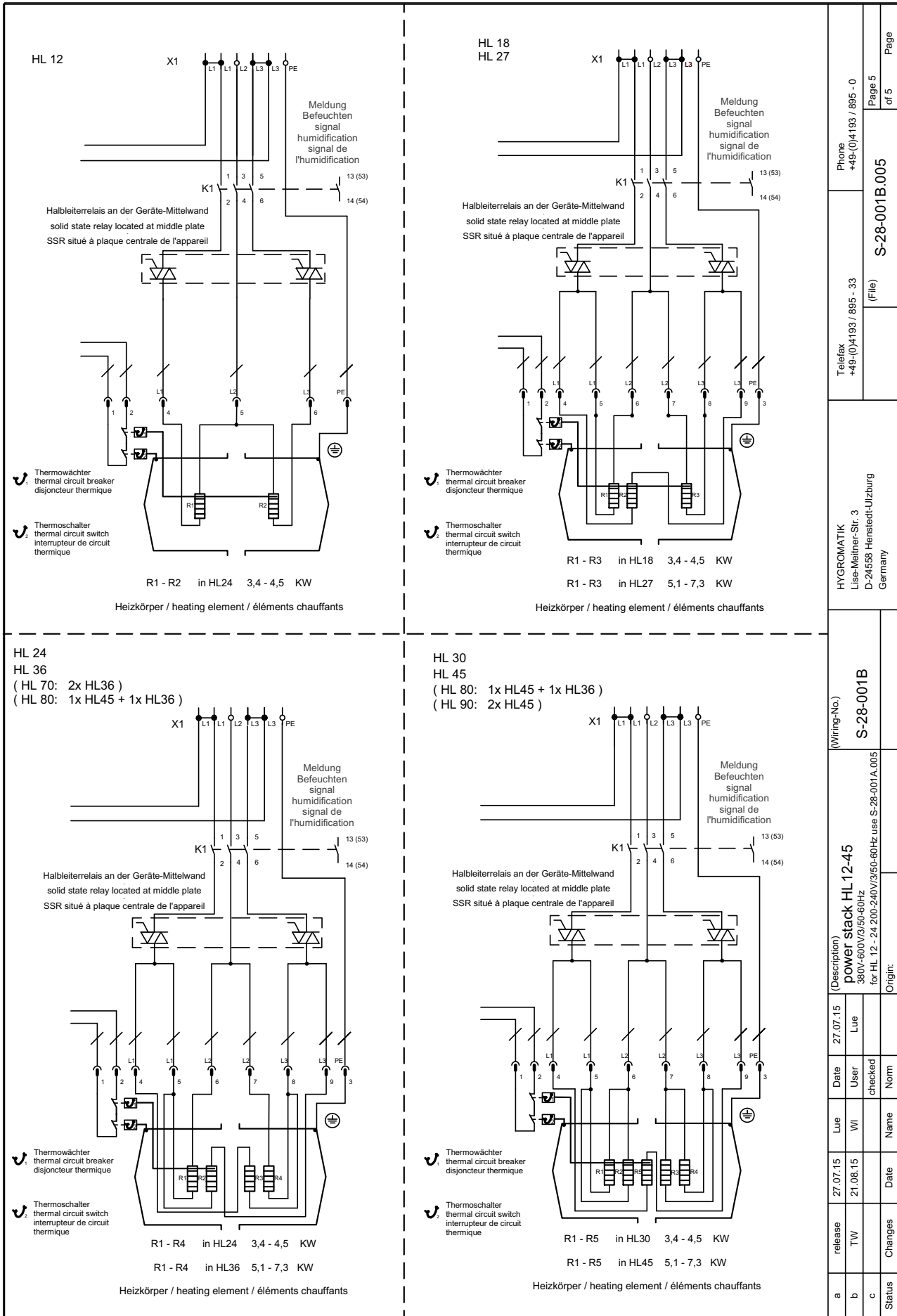

Phone +49-(0)4193 / 895 - 0		Page 5 of 5	
Telefax +49-(0)4193 / 895 - 33		S-28-001B.005 (File)	
HYGROMATIK Lise-Meiner-Str. 3 D-24568 Henstedt-Ujzburg Germany			
(Wiring-No.) S-28-001B		Origin:	
(Description) power stack HL 12-45 380V-600V/3/50-60Hz for HL 12 - 24 200-240V/3/50-60Hz	Date 27.07.15	User Lue	Norm
release 27.07.15	WI	checked	Name
TW	21.08.15		Date
a	Changes	Status	
b			
c			

16. Ordering Information / Table of Options

Ordering is that simple:

Steam generator with exact designation (e.g. HyLine: HY17 Comfort DS)

+ desired optional connection configurations (e.g. Option 24 V: B-0623091 for C06 - C10 or Hy 05 - Hy 08; B-0623093 for C17 - C 45 or Hy 13 -Hy 30)

+ steam bath accessories with article designation and article number (as needed)

Table of Options: Electrode Steam Generator

What connections* does your steam generator need ?			
Essence Pump	24 Volt	x	x
Supply and Exhaust Fans		x	x
Light		x	x
Transformer (only needed for 24 V devices)		x	x
When ordering one of these options, your unit comes with the connections marked with the crosses.		Option 24V B-0623113 for C17-45 OR HY 13-30 (Basic and Comfort)	Option 24V B-0623109 for C 58 OR HY 45 (Basic and Comfort)

* Optional connector terminals for the standard HyLine model and CompactLine with DS Control.

Steam Bath Accessories:

- Peristaltic Pump for Essence 24V B-2604079
 - T-piece 2 x DN25/1", 1 x DN6, VA
for essence feed into the steam hose B-2604067
 - T-piece 2 x DN40/1 1/2", 1 x DN6, VA
for essence feed into the steam hose B-2604069
 - Angle (elbow) DN25/1", 90°, VA E-2604030
 - Angle (elbow) DN40/1 1/2", 90°, VA E-2604036
 - Steam Hose DN25/1" E-2604012
 - Steam Hose DN40/1 1/2" E-2604013
 - Drain Hose DN25/1" E-2420423
 - Tube, Silicon, 6x1,5mm/ 0.24x0.06inch
for Essence Delivery E-2604070
 - Hose Clamp for DN6/1/4" E-8501055
 - Hose Clamp für DN25/1" E-2404004
 - Hose Clamp für DN40/1 1/2" E-2604016
- Spare Part (should be available as replacement part)
- Pump Tube, Peristaltic Pump, Silicon E-2604074

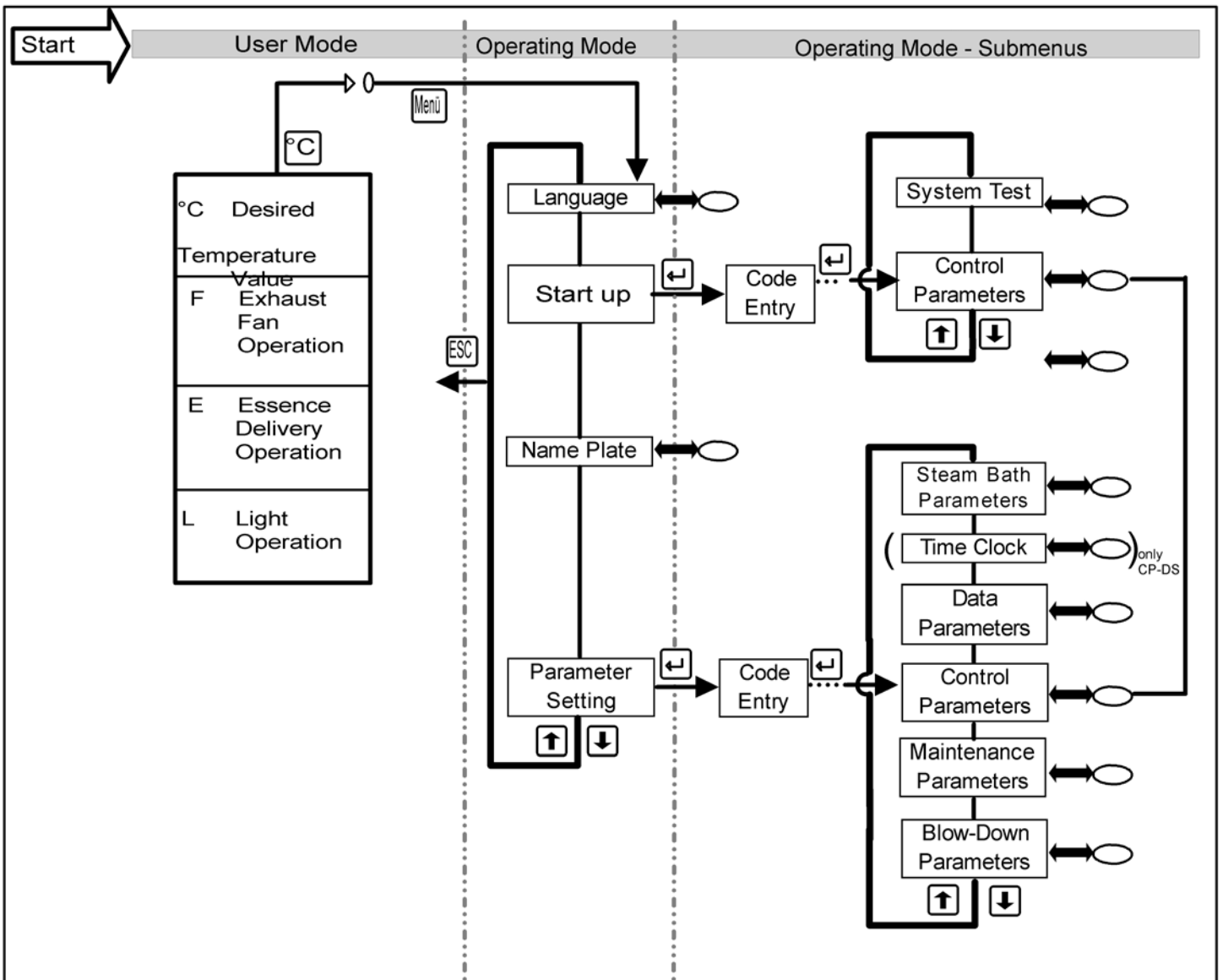

Explanation:

Toggleing between menus and submenus:

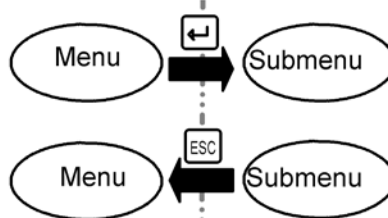

↔ indicate navigation to the next submenu



are software keys in the control display unit. They can be activated by pressing the keys located below them.

17. Technical Specifications

Technical Specifications Steam Humidifier HyLine (with control type Basic-DS, Comfort-DS, Comfort-Plus DS)						
Type		HY05	HY08	HY13	HY17	HY23
208V/3 Phase, 60 Hz Power supply	Steam output [kg/h]	5.0	7.7	13.0	14.4	23.0
	Power Usage [kW]	3.75	5.8	9.7	10.8	17.3
	Input [A]	10.4	16.0	27.0	30.0	47.9
	Circuit Protection [A]***	3x15	3x20	3x35	3x40	3x60
480V/3 Phase, 60 Hz Power supply	Steam output [kg/h]	5.0	8.0	13.0	17.0	23.0
	Power Usage [kW]	3.74	6.0	9.8	12.8	17.3
	Input [A]	4.5	7.2	11.7	15.3	20.7
	Circuit Protection [A]***	3x10	3x10	3x20	3x20	3x25
600V/3 Phase, 60 Hz Power supply	Steam output [kg/h]	5.0	8.0	13.0	17.0	23.0
	Power Usage [kW]	3.74	6	9.8	12.8	17.3
	Input [A]	3.6	5.8	9.4	12.3	16.6
	Circuit Protection [A]***	3x10	3x10	3x15	3x15	3x20
Control voltage		24V/ 208-240V				
Type		HY30	HY45	HY60	HY90	HY116
208V/3 Phase, 60 Hz Power supply	Steam output [kg/h]	28.8	38.4	57.6	76.9	-
	Power Usage [kW]	21.6	28.8	43.2	57.6	-
	Input [A]	60.0	80.0	2x60.0	2x80.0	-
	Circuit Protection [A]***	3x75	3x100	6x75	6x100	-
480V/3 Phase, 60 Hz Power supply	Steam output [kg/h]	30.0	45.0	60.0	90.0	116.0
	Power Usage [kW]	22.5	33.8	45.0	67.5	87.0
	Input [A]	27.1	40.6	2x27.1	2x40.6	2x52.3
	Circuit Protection [A]***	3x35	3x45	6x35	6x45	6x65
600V/3 Phase, 60 Hz Power supply	Steam output [kg/h]	30.0	45.0	60.0	90.0	116.0
	Power Usage [kW]	22.5	33.8	45.0	67.5	87.0
	Input [A]	21.7	32.5	2x21.7	2x32.5	2x41.9
	Circuit Protection [A]***	3x30	3x40	6x30	6x40	6x50
Control voltage		24V/ 208-240V				

Technical Specifications Steam Humidifier CompactLine C6-C58 (with Basic DS, Comfort DS/Plus control DS)							
Type		C6	C10	C17	C30	C45	C58
208V/3 Phase, 60 Hz Power supply	Steam output [kg/h]	6.0	7.7	14.4	28.8	28.8	38.4
	Power Usage [kW]	4.5	5.8	10.8	21.6	21.6	28.8
	Input [A]	12.5	16.0	30.0	60.0	60	80
	Circuit Protection [A]***	3x15	3x20	3x40	3x75	3x75	3x100
480V/3 Phase, 60 Hz Power supply	Steam output [kg/h]	6.0	10.0	17.0	30.0	45.0	58.0
	Power Usage [kW]	4.5	22.0	12.8	22.5	33.8	43.5
	Input [A]	5.4	7.2	15.3	27.1	40.6	52.3
	Circuit Protection [A]***	3x10	3x10	3x20	3x30	3x45	3x60
600V/3 Phase, 60 Hz Power supply	Steam output [kg/h]	-	10.0	17.0	30.0	45.0	58.0
	Power Usage [kW]	-	6.0	12.8	22.5	33.8	43.5
	Input [A]	-	5.8	12.3	21.7	32.5	41.9
	Circuit Protection [A]***	-	3x10	3x15	3x25	3x35	3x50
Control voltage		24V/ 208-240V					

Technical Specifications Steam Humidifier HeaterLine (with Basic DS, Comfort DS/Plus control DS)									
Type		HL6	HL9	HL12	HL18	HL24	HL30	HL36	HL45
208V/3 Phase, 60Hz Power supply*	Steam Output [kg/h]	5.0	X	10.0	15.0	20.0	X	X	X
	Power Rating [kW]	3.75	X	7.5	11.3	15.0	X	X	X
	Input [A]**	18.0	X	30.5	30.5	48.0	X	X	X
	Circuit Protection [A]	20.0	X	35.0	35.0	50.0	X	X	X
480V/3 Phase, 60Hz Power supply*	Steam Output [kg/h]	6.0	X	9.0	12.0	18.0	24.0	30.0	36.0
	Power Rating [kW]	4.5	6.8	9.0	13.5	18.0	22.5	27.0	33.8
	Input [A]**	9.4	14.1	16.3	24.5	25.7	32.5	39.6	48.0
	Circuit Protection [A]	10.0	16.0	20.0	25.0	35.0	35.0	40.0	50.0
600V/3 Phase, 60Hz Power supply*	Steam Output [kg/h]	6.0	X	9.0	12.0	18.0	24.0	30.0	36.0
	Power Rating [kW]	4.5	6.8	9.0	13.5	18.0	22.5	27.0	33.8
	Input [A]**	7.5	11.3	13.0	19.5	20.5	26.0	30.8	39.0
	Circuit Protection [A]	10.0	16.0	16.0	20.0	25.0	35.0	35.0	40.0
	Numer of Heater Elements	1	1	2	2	4	5	4	5
Control voltage		24V/ 208-240V							
* Other voltages upon request		*** Current load of phases is not uniform. X=not available							



HyGROMATIK[®]

Lise-Meitner-Str.3 • D-24558 Henstedt-Ulzburg
Phone +49(0)4193/ 895-0 • Fax -33
eMail hy@hygromatik.de • www.hygromatik.com
A member of the **spirax/sarco** Group