

HYGROMATIK®

SteamKit H

Heater Steam Humidifier Kit



Manual



KITH.EN
E-8881178

Certain computer programs contained in this product [or device] were developed by HygroMatik GmbH ("the Work(s)").

Copyright © HygroMatik GmbH [12.01.2022]

SteamKit H

KIT H02/03/06/09/15/ 25/ 30/ 40/ 50

All Rights reserved.

Current version of this manual to be found on: www.hygromatik.com

HygroMatik GmbH grants the legal user of this product [or device] the right to use the Work(s) solely within the scope of the legitimate operation of the product [or device]. No other right is granted under this licence. In particular and without prejudice to the generality of the foregoing, the Work(s) may not be used, sold, licensed, transferred, copied or reproduced in whole or in part or in any manner or form other than as expressly granted here without the prior written consent of HygroMatik GmbH.

Information in this manual is subject to change or alteration without prior notice.

Please note

Ensure that the system/machine in which the HygroMatik installation kit will be installed fully complies with the regulations of the directives (2006/42/EC) and the EMC directive 2014/30/EU and that all safety-relevant functions have been implemented in the control system.

⚠ WARNING

Risk of electrical shock!

Hazardous electrical voltage!

All electrical work to be performed by certified expert staff (electricians or expert personnel with equivalent training) only.

⚠ WARNING

Risk of scalding!

Steam with a temperature of up to 100 °C is produced.

Do not inhale steam directly!

1. Introduction	5
1.1 Typographic Distinctions	5
1.2 Documentation	5
1.3 Symbols in Use	5
1.3.1 Specific Symbols related to Safety Instructions	5
1.3.2 General Symbols	5
1.4 Intended Use	6
1.5 Possibility of certification	6
2. Safety Instructions	7
2.1 Guidelines for Safe Operation	7
2.1.1 Scope	7
2.1.2 Unit control	7
2.1.3 Unit Operation	7
2.1.4 Mounting, dismantling, maintenance and repair of the unit	8
2.1.5 Electrical	8
3. Transport	9
3.1 Overview	9
3.2 Packing	9
3.3 Interim Storage	9
3.4 Check for complete and correct delivery of goods	9
4. Functional Description and Device Composition	10
4.1 Mode of Action	10
4.2 Mechanical Construction	10
4.3 Operational Sequence	11
4.4 Internal Output Setting	11
5. Mechanical installation	12
5.1 Environment parameters to be met	12
5.2 Mounting recommendations	12
5.3 Dimensions of the unit	13
5.4 Dimensions of the board	14
5.5 Unit Installation Check	14
5.6 Absorption Distance BN	15
5.6.1 Determining the Absorption Distance	15
5.6.2 Absorption Distance Nomogram	16
5.7 Steam line and condensate hose layout	17
5.7.1 Guide lines for steam line design	17
5.7.2 Condensate hose layout	17
5.7.3 Steam line and condensate hose installation types	18
5.8 Steam Manifold	19
5.8.1 General installation guidelines	19
5.8.2 Recommendations for dimensioning	19
6. Water connection	22
6.1 Water supply	22

6.2 Water discharge	23
6.3 Water connections final check	23
7. Electrical connection	24
7.1 Electrical installation approach	24
7.2 Safety interlock	25
7.3 Internal electrical connection	25
7.3.1 Overview	25
7.3.2 Internal electrical eonnection w/o HygroMatik control	26
7.3.3 Internal Electrical Connection when the kit is delivered with a HygroMatik control	26
7.4 Connection diagrams	26
8. Commissioning	27
9. Maintenance	28
9.1 General	28
9.1.1 Safety instructions for maintenance	28
9.2 Maintenance frame work when unit is operated with fully demin. water and condensate .	29
9.3 Maintenance when unit is operated with tap water or partially softened water	29
9.4 Maintenance steps	30
9.4.1 Removal of the steam cylinder	30
9.4.2 Cylinder cleaning / O-ring replacement	30
9.4.3 Cleaning the connecting hoses, base connections, fine filter and drain pump	32
9.4.4 Level control device cleaning	32
9.4.5 Cleaning the vent hole on the pipe elbow	33
9.4.6 Reinstallation of the steam cylinder	33
9.5 Removal and installation of unit components	34
9.6 Blow-down pump (removal, cleaning, reinstallation)	34
9.6.1 Solenoid valve (removal, reinstallation)	35
9.7 Leak test	35
9.8 Functional check	35
10. Dismantling	36
11. Spare parts	37
12. Exploded view	39
13. Technical specifications	43

1. Introduction

Dear Customer,

Thank you for choosing a HygroMatik steam humidifier kit (referred to as „kit“ in the descriptions following hereafter).

HygroMatik kits represent the latest in humidification technology.

In order to operate your kit safely, properly and efficiently, please read these operating instructions.

Employ your kit only in sound condition and as directed. Consider potential hazards and safety issues and follow all the recommendations in these instructions.

If you have additional questions, please contact your expert dealer.

For all technical questions or spare parts orders, please be prepared to provide unit type and serial number (see name plate on the unit).

1.1 Typographic Distinctions

- preceded by a bullet: general specifications
- » preceded by an arrow: Procedures for servicing or maintenance which should or must be performed in the indicated order
- ☑ Installation step which must be checked off.

italics Terms used with graphics or drawings

1.2 Documentation

Retention

Please retain these operating instructions in a secure, always accessible location. If the product is resold, turn the documentation over to the new operator. If the documentation is lost, please contact HygroMatik.

Versions in Other Languages

These operating instructions are available in several languages. If interested, please contact HygroMatik or your HygroMatik dealer.

Co-applicability

If the kit is ordered and delivered with a HygroMatik control, the manual of that control must be regarded as an applicable document.

1.3 Symbols in Use

1.3.1 Specific Symbols related to Safety Instructions

According to ANSI Z535.6 the following signal words are used within this document:

⚠ DANGER

DANGER indicates a hazardous situation which, if not avoided, will result in death or serious injury.

⚠ WARNING

WARNING indicates a hazardous situation which, if not avoided, could result in death or serious injury.

⚠ CAUTION

CAUTION indicates a hazardous situation which, if not avoided, could result in minor or moderate injury.

NOTICE

NOTICE is used to address practices not related to physical injury.

1.3.2 General Symbols

Please note

This symbol is used whenever a situation requires special attention beyond the scope of safety instructions.

1.4 Intended Use

HygroMatik electric heater steam humidifiers serve for steam production based on tap water, partially softened water or fully desalinated water/cleaned condensate.

Proper usage also comprises the adherence to the conditions specified by HygroMatik for:

- installation
- dismantling
- reassembly
- commissioning
- operation
- maintenance
- disposal

Only qualified and authorised personnel may operate the unit. Persons transporting or working on the unit must have read and understood the corresponding parts of the Operation and Maintenance Instructions and especially the chapter 2. „Safety Notes“. Additionally, operating personnel must be informed of any possible dangers. You should place a copy of the Operation and Maintenance Instructions at the unit's operational location (or near the unit).

By construction, the kit is not qualified for exterior application.

▲WARNING

Risk of scalding!

Steam with a temperature of up to 100 °C is produced.

Do not inhale steam directly!

1.5 Possibility of certification

HygroMatik humidifiers are certified according to the household appliance standard DIN EN 60335-1 in accordance with the special requirements for humidifiers DIN EN 60335-2-98 and comply with the requirements of the EC Low Voltage Directive 2014/35/EU contained therein.

It has been shown by the legislator through a risk analysis in accordance with the Machinery Directive that the risks are mainly of electrical origin and that all essential safety requirements of the Machinery Directive together with the main objectives of the Low Voltage Directive are covered by the EN 60335-2-98 standard.

HygroMatik humidifier installation kits correspond in their construction to the certified humidifiers. Due to the lack of enclosure, wiring and only optional control, they are incomplete in the broader sense, but not an incomplete machine in accordance with the Machinery Directive 2006/42 / EC.

2. Safety Instructions

These safety instructions are required by law. They promote workplace safety and accident prevention.

2.1 Guidelines for Safe Operation

2.1.1 Scope

Comply with the accident prevention regulation „DGUV Regulation 3“ to prevent injury to yourself and others. Beyond that, national regulations apply without restrictions. This way you can protect yourself and others from harm.

2.1.2 Unit control

Do not perform any work which compromises the safety of the unit. Obey all safety instructions and warnings present on the unit.

In case of a malfunction or electrical power disruption, switch off the unit immediately and prevent a restart. Repair malfunctions promptly.

⚠ WARNING

Restricted use.

IEC 60335-1 stipulates as follows:

This device may be used by children of eight years of age and above as well as by persons with reduced physical, sensory or mental capabilities or lack of experience and knowledge so long as they are supervised or have been instructed regarding the safe use of the device and understand the hazards that may result from it. Cleaning and user maintenance of the unit must not be undertaken by children without supervision.

The following applies to the HygroMatik installation kits:

Please note

Ensure that the system/machine in which the HygroMatik installation kit will be installed fully complies with the provisions of the directives (2006/42/EC) and the EMC directive 2014/30/EU and that all safety-relevant functions have been implemented in the control system.

2.1.3 Unit Operation

⚠ WARNING

Risk of scalding!

Uncontrolled hot steam escape in case of leaking or defective components possible. Switch off unit immediately.

⚠ WARNING

For Ministeam devices applies:

Risk of scalding!

No persons may be under the cloud of steam blowing out (at a distance of approx. 1 m/40 inch in the direction of blowing out and 0.5 m/20 inch on both sides of the device).

NOTICE

Risk of material damage!

- The unit may be damaged if switched on repeatedly following a malfunction without prior repair. Rectify defects immediately!
- The unit must not be operated on a DC power supply.
- The unit may only be used connected to a steam pipe that safely transports the steam (not valid for MiniSteam units).
- Regularly check that all safety and monitoring devices are functioning normally. Do not remove or disable safety devices.
- Steam operation is only allowed when the unit cover is closed.

NOTICE

Water leaks caused by defective connections or malfunctions are possible.

Water is constantly and automatically filled and drained in the humidifier. Connections and water-carrying components must be checked regularly for correct operation.

2.1.4 Mounting, dismantling, maintenance and repair of the unit

NOTICE

The HygroMatik steam humidifier is IP20 protected. Make sure that the unit is not object to dripping water in the mounting location.

Installing a humidifier in a room without water discharge requires safety devices to protect against water leakages.

- Use genuine spare parts only
- After any repair work, have qualified personnel check the safe operation of the unit
- Attaching or installing of **additional components** is permitted only with the **written consent** of the manufacturer

NOTICE

Do not install HygroMatik steam generators above electrical equipment such as fuse boxes, electrical appliances, etc. In the case of a leakage, leaking water can damage the underlying electrical equipment

2.1.5 Electrical

▲WARNING

Risk of electrical shock!

Hazardous electrical voltage!

Any work on the electrical system to be performed by certified expert staff (electricians or expert personnel with comparable training) only.

Steam operation may only be started when the unit cover is closed.

During maintenance or installation work, the device must be disconnected from the power supply and secured against being switched on again. The absence of voltage must be ensured by a measurement.

Leaks can cause leakage currents. Observe safety regulations on working with voltage parts (applies to electrode steam humidifiers).

After electrical installation or repair work, test all safety mechanisms (such as grounding resistance).

NOTICE

Use only original fuses with the appropriate amperage rating.

Regularly check the unit's electrical equipment. Promptly repair any damage such as loose connections or burned wiring.

Responsibility for intrinsically safe installation of the HygroMatik steam humidifiers is incumbent on the installing specialist company.

3. Transport

3.1 Overview

Please note

Proceed carefully when transporting the kit in order to prevent damage due to stress or careless loading and unloading.

3.2 Packing

Please note

Pay attention to the icons affixed to the packing box.

3.3 Interim Storage

Store the unit in a dry place and protect from frost and strong sunlight.

3.4 Check for complete and correct delivery of goods

Upon receipt of the unit, confirm that model and serial number on the name plate match those specified in the order and delivery documents.

Scope of delivery

Qty.	Item
1	Console with steam cylinder/ cylinder base, solenoid valve, blow-down pump, internal tubing with elbow
1	SteamKit manual
1	Steamhose adaptor
1	O-Ring for cylinder base and steamhose adaptor
1	Clamp 20 - 32 mm for steam hose DN25
1	Cylinder connection coupling and plug 4 mm ²

Qty.	Item
4	Blade receptacle for connection of solenoid valve and blow-down pump
4	Insulating sleeve
1	Ring cable lug for grounding
1	Water level detection / control cylinder
1	Control (optional)
1	„Control“ manual
1	Display
1	Solid State Relais

Pls., check whether the equipment is complete and all parts are in perfect condition.

Please note

A main contactor is not included and must be supplied on-site. For selection, pls. keep max. current draw of the kit in mind as specified in the electrical connection section (section 10).

Claim

In case of damage from shipment and/or missing parts, immediately notify the carrier or supplier in writing.

Time limits for filing freight claims with shipping companies are*:

Shipping company	After receipt of goods
Carriers	no later than 4 days
Parcel service	immediately

* Time limits for some services subject to change.

4. Functional Description and Device Composition

4.1 Mode of Action

The immersion heater principle

Depending on the output rating, one or three heater elements are arranged within a closed cylinder. The cylinder is filled with either tap water of varying quality, fully desalinated water or partially softened water. The heat introduced by the heater element(s) heats up the cylinderwater to approx. 100 °C, transforming the water into steam with a temperature of approx. 100 °C and very little positive pressure (so called pressureless steam). This steam is virtually mineral-free and germ-free. When fully desalinated water is used, the cylinder water is almost totally clear of minerals. This situation guarantees a long lifetime of the cylinder and the heater element(s), since virtually no hardeners will fall out and no mineral deposits will occur.

Such, the number of inspections and/or maintenance operations required will be reduced to a minimum.

When tap water is used for operation, some of the minerals dissolved in the water are likely to settle in the cylinder in form of solids of various compositions. However, most of the solids are flushed out by cyclic blow-down with the help of a heavy-duty blow-down pump.

4.2 Mechanical Construction

The kits are designed for wall mounting or standing on a horizontal, level surface.

The composition of a kit with 1 heater element is shown in the fig. following hereafter.

For maintenance purposes, the steam cylinder is separable in the middle.

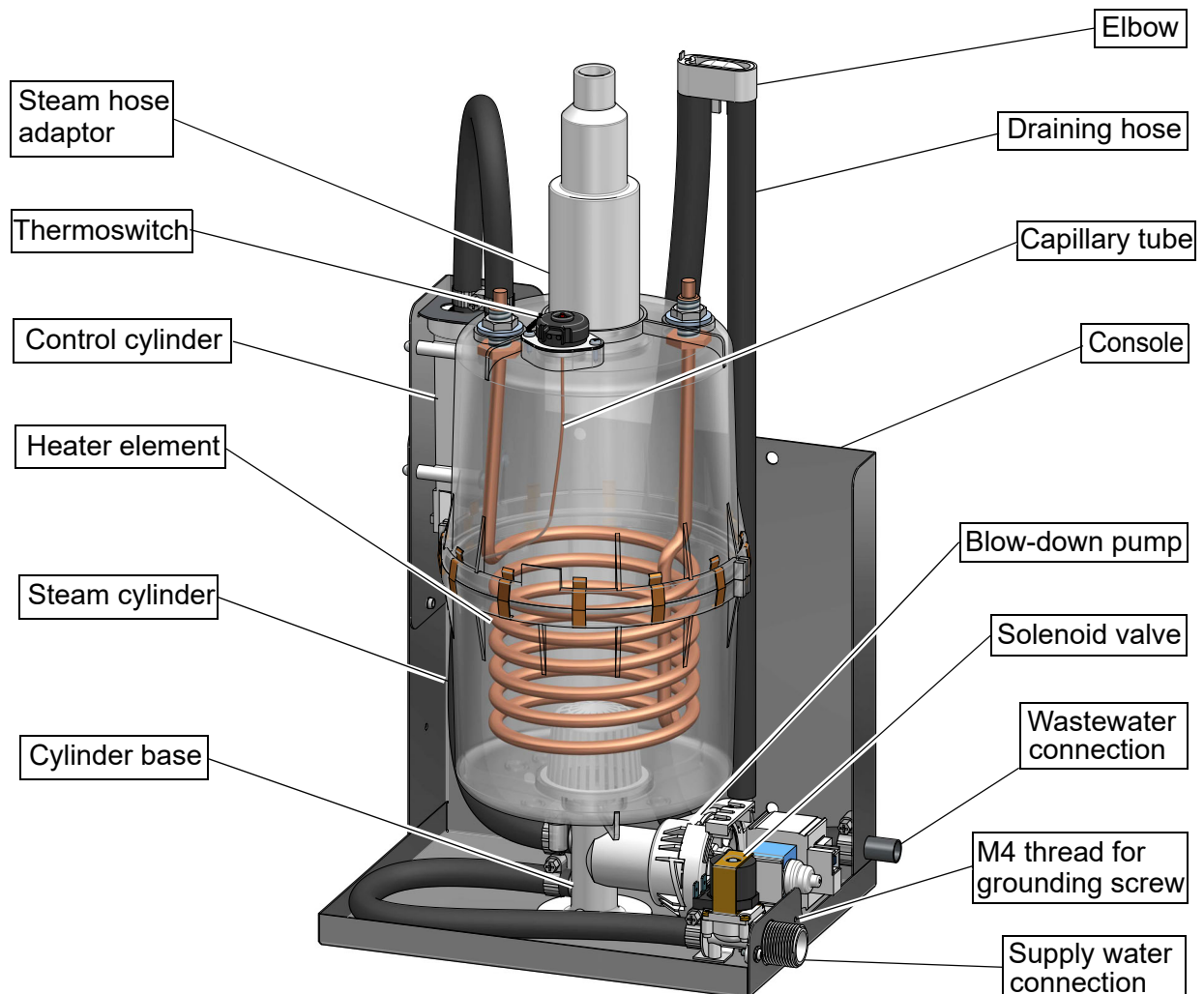

4.3 Operational Sequence

The operational sequence depends on the electrical interconnection and control of the kit. Following hereafter, the typical operational sequence is described for a setting of the kit with the HygroMatik control „Standard“:

The steam humidifier is switched on by pressing the control switch on the front panel to the „I“ position. When the controller generates a demand for humidification, the inlet solenoid valve (25)* opens and water is fed into the steam cylinder.

Filling level in the cylinder is controlled by a level control device (27)*. In a plastic cylinder, connected to the steam cylinder via hoses in the way communicating tubes are connected, a sensor for continuous proportional water level survey is located.

The cylinder water is periodically blown down. For usage of the unit with fully desaturated water, the blow-down function may be blocked.

Water blow-down is achieved by means of the blow-down pump (32)* that is continuously monitored during unit operation. In case of pump disruption, the kit is shut off.

With normal water quality, blow-down loss is in the range of 7 to 15 % of the steam amount produced. Depending on water quality, a full steam cylinder blow-down is run every 3 to 8 days.

Mineral deposits settle in the open area below the heater element(s) and are removed through periodic maintenance. The blow-down pump itself has wide openings and can flush out smaller pieces of mineral deposit. This extends the service life of the unit and reduces the required maintenance interval.

On blow-down, water flows from the pump into the drain hose system.

For maintenance purposes, the cylinder water may be pumped out by pressing and holding the control switch in the „II“ position.

*) numbers indicated correspond with those in the exploded view in the „Exploded view“ chapter.

4.4 Internal Output Setting

The description following hereafter relates to the usage of the steam humidifier kit with the HygroMatik controls „Basic“ and „Standard“.

Continuous control is achieved by proportional driving (pulse width modulation) of the heater element(s). In this way the steam humidifier kit can be proportionally operated across the entire output range of 10 % - 100 % of the nominal capacity.

5. Mechanical installation

⚠ WARNING

Risk of foot injuries!

Prevent unit from dropping during installation! Helping hand of a second person is advisable.

⚠ WARNING

Risk of electrical shock!

Hazardous electrical voltage. During installation, the unit must be disconnected from power supply and secured against being switched on again. The absence of voltage must be ensured by a measurement.

5.1 Environment parameters to be met

- By design, the kits are not qualified for outdoor installation since electrical/electro-mechanical/electronic components (depending on configuration variant) and water-bearing parts may be damaged
- Ambient temperature must lie between +5 and +40 °C (+41 and +104 °F) ; frost may damage the steam cylinder, the solenoid valve and pump, as well as make hoses burst
- Relative humidity must not exceed 80 % r.h., since values beyond may lead to electronic malfunction or damage
- Installation in a closed room requires aeration and, eventually, temperature conditioning in order to meet the a.m. environmental conditions

5.2 Mounting recommendations

When selecting the installation site for the steam humidifier, take the following into account:

- The kit should be installed as close as possible to the steam manifold. Optimum performance is only guaranteed when steam and condensate hoses are kept short
- Make use of existing water connections for supply and draining
- Hoses must be laid at a consistent 5 to 10 % incline/decline; sagging and kinking prevention is a must
- Mount the unit on a stable, preferably solid wall offering the bearing capacity required (s. unit technical specifications) or standing on a horizontal, level surface. If such a wall is not at hand, the unit may be attached to a stand bracket firmly bolted to the floor.
- The steam humidifier console heats up during operation. Take care that the construction on which the unit is to be mounted is not made of temperature-sensitive material.
- The elbow is to be attached to a suitable vertical surface by means of a screw

When selecting the mounting material to be supplied by the customer, attention must be paid to adequate strength. For the correct functioning of the steam humidifier it is required that the device is mounted level and plumb.

After mounting the kit make sure that it sits firmly.

NOTICE

To fulfil all safety requirements, ensure sufficient ventilation of the installation kit in the housing.

5.3 Dimensions of the unit

Table of dimensions

Model	A [mm]	B [mm]	C [mm]	E1 [mm]	E2 [mm]	H1 [mm]	H2 [mm]	H3 [mm]	H4 [mm]	L1 [mm]	L2 [mm]
KIT E02 / KIT H02	300	220	400	157,5	125	30	25	42	226	15	185
KIT E06	300	220	530	157,5	125	30	25	42	226	15	185
KIT E10 / KIT H03/06/09	300	220	550	157,5	125	30	25	42	226	15	185
KIT E15 /20/30/ KIT H15/25	350	285	700	270	270	35	25	80	160	15	250
KIT E45/65 / KIT H30/40/50	420	400	785	280	280	35	25	100	200	15	365

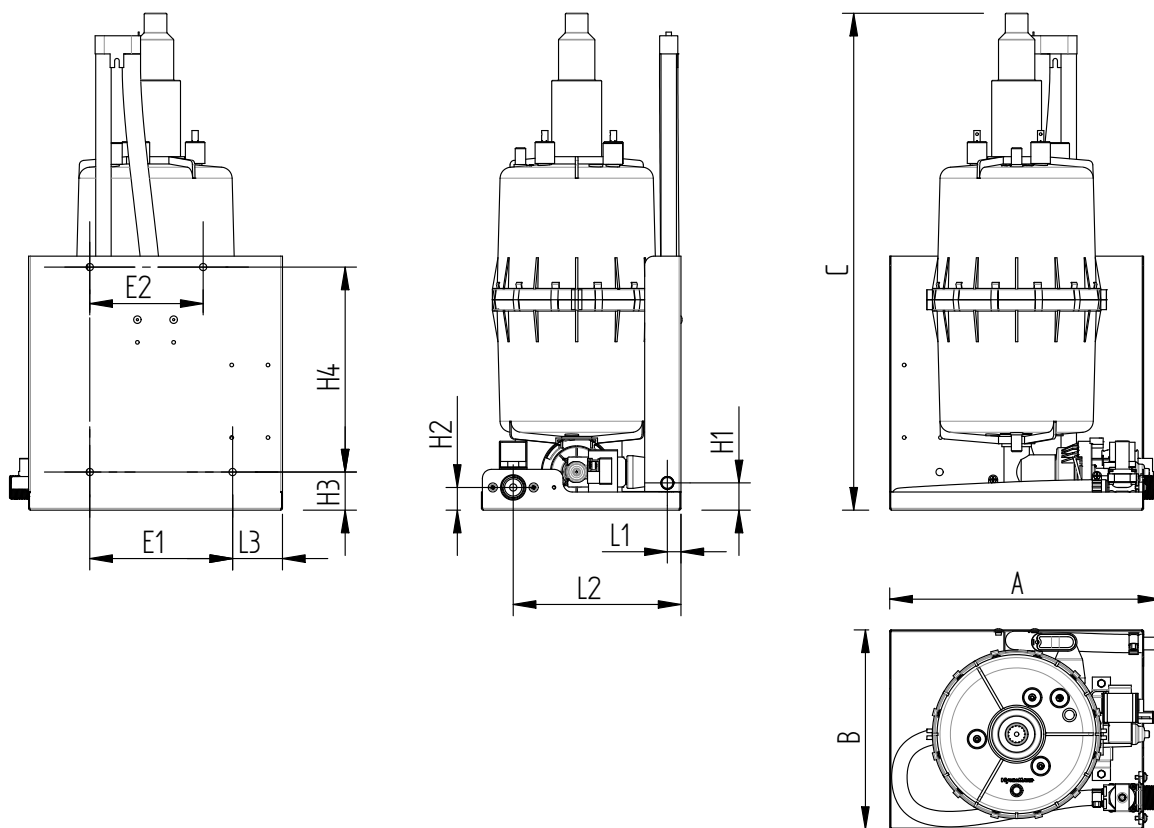

5.4 Dimensions of the board

FlexLine / StandardLine

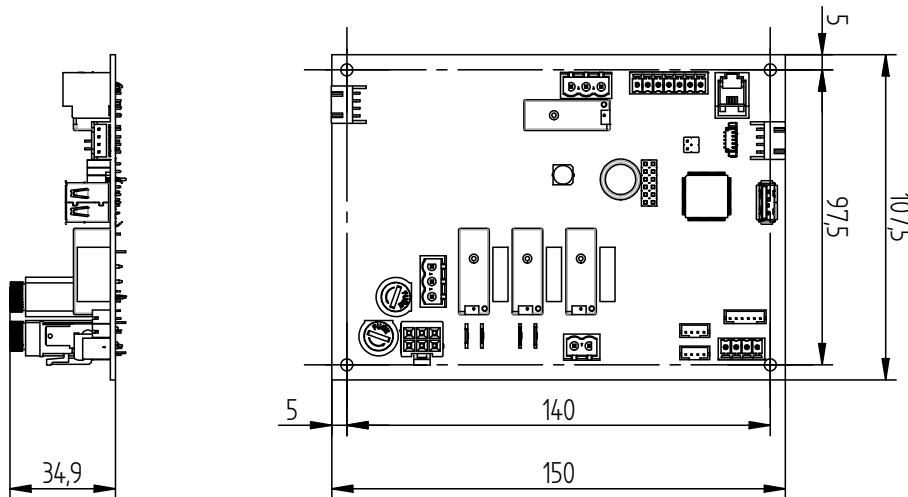

5.5 Unit Installation Check

Before start-up, pls. check proper unit installation following the list below:

- Kit perpendicularly aligned in both the vertical and horizontal axis ?
- Steam hose installed with a 5 - 10 % minimum incline/decline (see chapter "Steam line") ?
- Condensate hose features a loop functioning as a steam barrier (see chapter „Condensate hose“) ?
- Steam manifold(s) properly positioned?
- All bolts and clamps properly tightened?
- Steam manifold(s) horizontally mounted and suspended on the free end, if required ?
- All seals (o-rings) in place?

5.6 Absorption Distance B_N

The "absorption distance" (B_N) is defined as the distance from the steam feed to where the steam is completely absorbed in the treated air. Within the absorption distance, steam is visible as mist in the air stream.

Condensation may occur on anything installed within the absorption distance.

Although steam outside the absorption distance (B_N) is completely absorbed, it is not yet evenly diffused in the duct. If you plan to install any parts or devices inside the absorption distance, such as sensors or elbows, we recommend increasing the absorption distance using the formulae below. The absorption distances required for certain installed fittings are distinguished by separate symbols and calculated as a multiplier of the absorption distance B_N .

Absorption Distance	
B_N	for normal obstructions such as sensors, ventilators, outlets
$B_C = (1.5...2) \times B_N$	for fine filters, heat registers
$B_S = (2.5...3) \times B_N$	for particle filters
$B_d = (3...5) \times B_N$	for humidity sensors, duct humidistats

The absorption distance has no fixed value, but depends on many factors. These are depicted in the absorption distance nomogram below.

5.6.1 Determining the Absorption Distance

To determine the absorption distance, the following parameters are required:

- Air humidity before humidification x_1 in g/kg
- Air temperature after humidification t_2 in °C (with steam humidifiers the change in air temperature due to humidification may be disregarded t_1 or t_2)
- Specific increase in humidity Δx in g/kg (can be determined in the h,x diagram)
- quantity of steam introduced $\overset{o}{m}_D$ in kg/h.
- air speed w_L in m/s in air duct
- Total length l_D of the steam manifold installed in the air duct

Length l_D of the usable steam manifold depends on the dimensions of the air duct. The length of the absorption distance can be reduced by using multiple steam manifolds (also see section on the steam manifold).

Method:

Graphically determine absorption distance B_N using the absorption distance nomogram (also see Section „Absorption Distance Nomogramm“). Enter the value of the parameters enumerated above into the respective quadrants. The resulting point of intersection indicates the value of the desired absorption distance B_N .

Notes:

Air humidity before humidification x_1 :.....[g/kg]

Air temperature after humidification t_2 :.....[°C]

Specific increase in humidity Δx :.....[g/kg]

Quantity of steam introduced $\overset{o}{m}_D$:.....[kg/h]

Air speed w_L :.....[m/s]

Total length of steam manifold l_D :.....[mm]

5.6.2 Absorption Distance Nomogram

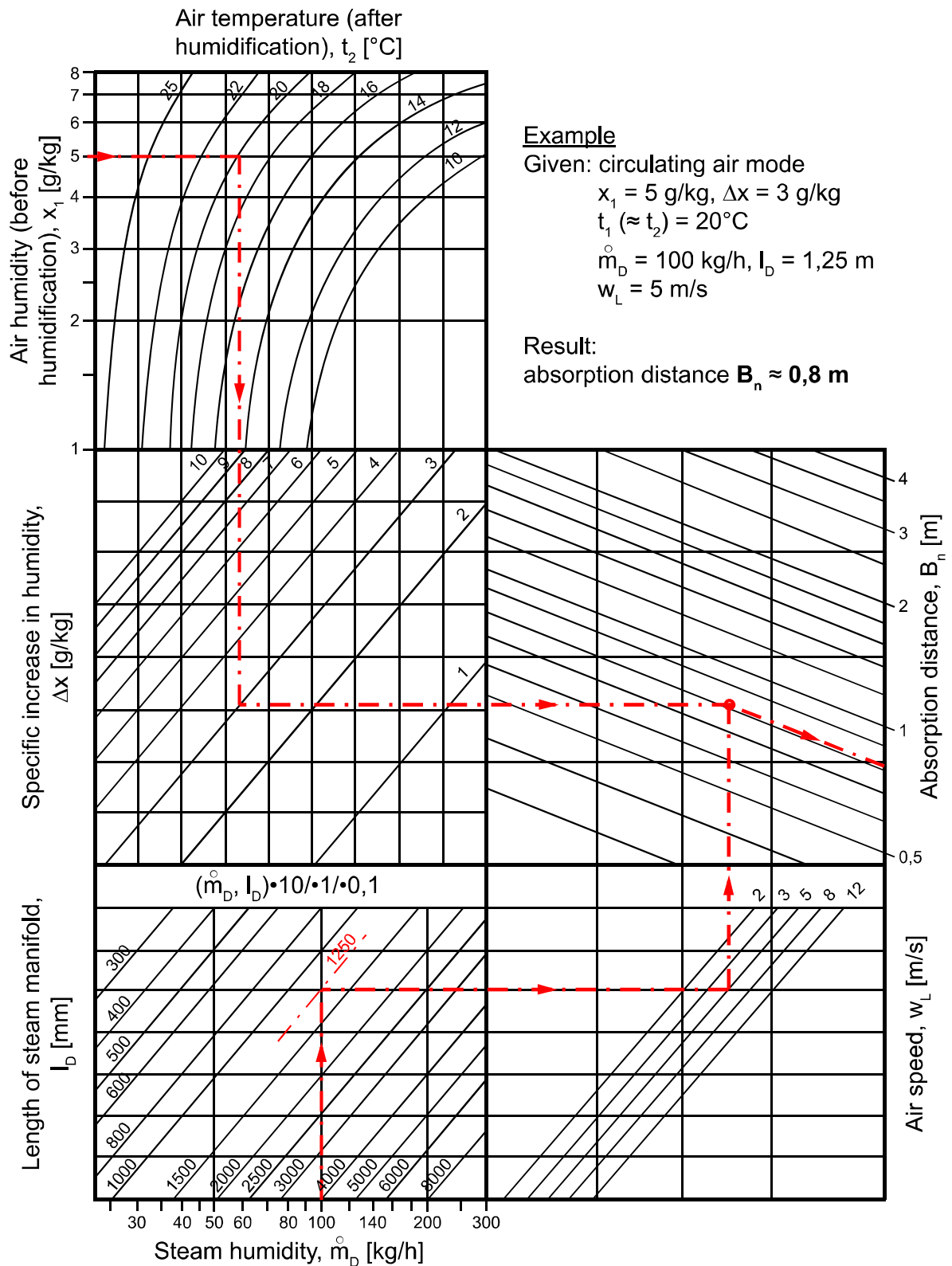

Source: Henne, Erich: Luftbefeuchtung (Air Humidification), 3rd Edition 1984 (Page 101), Oldenbourg Industrieverlag, Munich

5.7 Steam line and condensate hose layout

Please note

Because of the high requirements on hose material under the operating conditions given, it is recommended to use genuine HygroMatik hoses only.

5.7.1 Guide lines for steam line design

- Steam hose nominal diameter must not be smaller than the steam outlet of the HygroMatik steam humidifier (do not restrict the cross-section, otherwise back pressure will increase)
- Steam hoses must be laid without sags and kinks and with a continuous slope of 5-10% (otherwise sags may result).
- Steam hoses must be supported every 500 mm (20 inches) by clamp brackets
- Steam hoses should be kept as short as possible. Implement lengths beyond 5 m (16 ft.) as insulated fixed piping to keep energy loss and condensate generation to a minimum. Beyond 10 m (32 ft.) insulated installation is a must. Fixed piping is generally recommended for straight steam line segments
- When 2 steam manifolds are in use (other than with a standard implementation), place steam Y piece as close as possible to the steam manifolds. Such, for the main part of the piping just one steam hose is required and condensate loss is minimized
- Allow easy access to the steam pipe/ steam hose installation
- Pressure conditions within the duct are influenced by device steam output, steam line layout and the duct composition itself. In some rare situations it may become necessary to optimize steam line layout for achieving the results intended
- Respect minimum bending radii:
 DN 25 Steam hose: $R_{min} = 200 \text{ mm}/8''$
 DN 40 Steam hose: $R_{min} = 400 \text{ mm}/16''$

5.7.2 Condensate hose layout (only for electrode steam humidifiers)

The condensate hose may be run from the steam manifold back to the steam cylinder, as depicted in the schematic drawing below with concern to installation type 1. Alternatively, the condensate hose may be fed directly in a wastewater pipe or a drain (s. installation type 2).

Please note

Should condensate return into the steam cylinder be intended, the connection stub on the cylinder upper part must be drilled out first with a ANSI drill size „O“ drill. To do so, the steam cylinder must be removed from the housing (s. maintenance chapter, section „Steam cylinder removal and reinstallation“). In case of a console instead of a housing, the cylinder is to be lifted off the cylinder base for drilling the stub or may even remain in place.

Drill out condensate hose connection stub with an 8 mm (ANSI drill size „O“) drill, if required

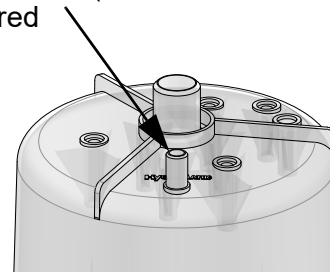

Steam cylinder top view

For heater element humidifiers:

If condensate return is necessary, please contact the HygroMatik hotline.

5.7.3 Steam line and condensate hose installation types

Installation type 1

Steam manifold is positioned more than 500 mm above device upper edge:

- » Run steam hose to a height of 400 mm/16 inch minimum above the steam humidifier and then to the steam manifold with a continuous incline of 5 to 10 %.
- » Feed condensate hose from steam manifold with a decline into waste-water pipe or drain.
- » As a steam barrier, lay out a 200 mm/8 inch min. loop (s. schematic representation below). Minimum distance from steam manifold to loop must be 500 mm/20 inch. Fill loop with water prior to steam humidifier commissioning.

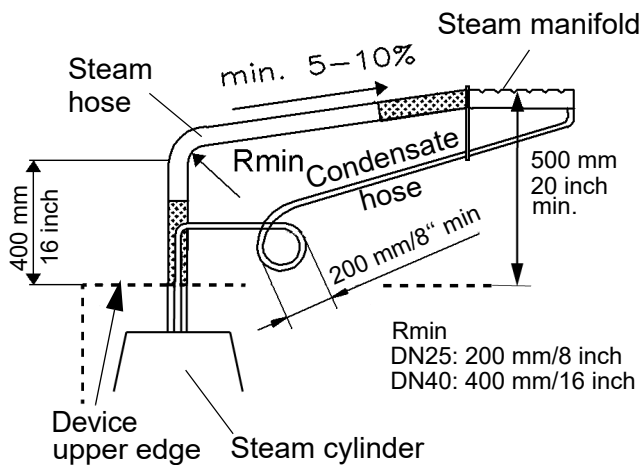

**Installation type 1,
schematic representation**

Installation type 2

Steam manifold is positioned less than 500 mm above or below device upper edge:

Please note

In this arrangement the condensate hose cannot be fed back to the steam humidifier.

- » Run steam hose to a height of 400 mm/16 mm minimum above the steam humidifier and then to the steam manifold with a continuous decline of 5 to 10 %.
- » Feed condensate hose to a waste-water pipe/drain with a 200 mm/8 inch diameter loop as a steam barrier. Minimum distance from steam manifold to loop must be 500 mm/20 inch. Fill loop with water.

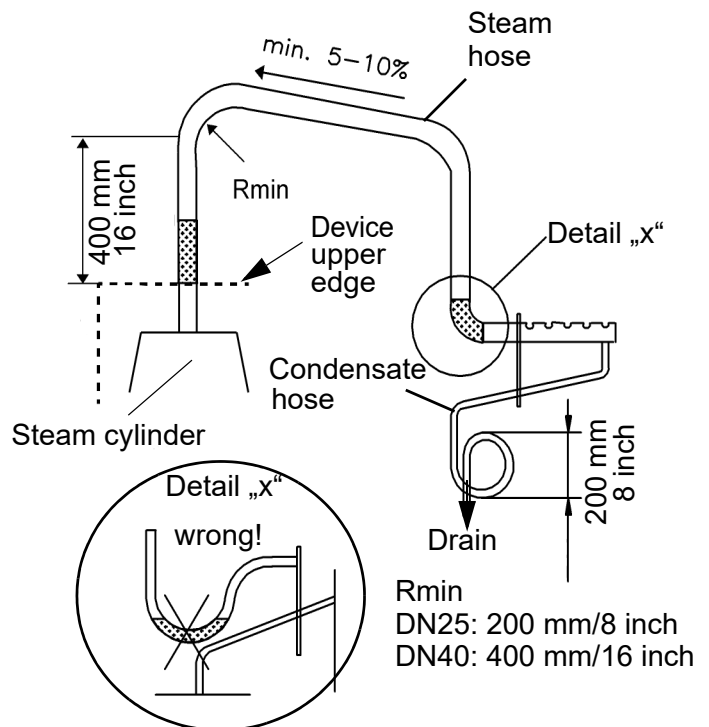

**Installation type 2,
schematic representation**

5.8 Steam Manifold

5.8.1 General installation guidelines

When installing steam manifolds, pls. follow these guidelines:

Positioning within duct

- Install the steam manifold as close as possible to the steam humidifier in order to minimize steam loss through condensation
- Steam manifold placement on the supply side of the air duct is preferable
- Install steam manifold strictly horizontal in order to ensure proper condensate drain
- Shown installation and positioning dimensions are based on empiric values. Special environmental conditions may require adjustments. Pay special attention to avoid condensate generation in air duct

Allowable pressures

- Max. allowable pressure in air duct is 1500 Pa/.218 PSI (exemption: SLE02, SLH02, KIT E02 and KIT H02 only allow for 1200 Pa/.174 PSI)
- On suction side, max. -500 Pa (.07 PSI) is tolerable
- With high-pressure air conditioning systems, modifications of the unit's drain hose system may possibly be required depending on the overall pressure situation. These modifications must be **coordinated with your expert dealer.**

Water drain

- We point out that according to the German Association of engineers (VDI) guideline VDI 6022, a water drain must be provided within the absorption distance inside the air duct

When increased airflow speed is encountered

- Air flow rates beyond 3m/s (9.84 ft/s) may lead to condensate drainage problems at the steam manifolds due to vacuum built-up. A possible remedy is twisting the steam manifold in its horizontal axis by few angular degrees. In case of problems, pls. consult your expert dealer.

5.8.2 Recommendations for dimensioning

The recommendations given below are based on homogenous air flow in the duct.

Horizontal installation of steam manifold

Standard steam manifold arrangement:

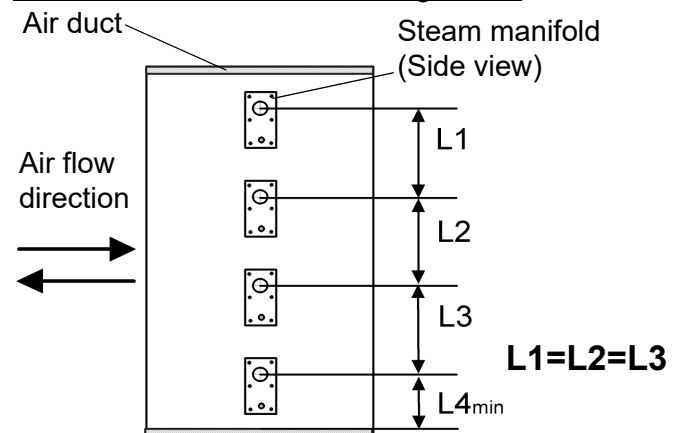

An even distribution of steam manifolds ensures a uniform steam distribution.

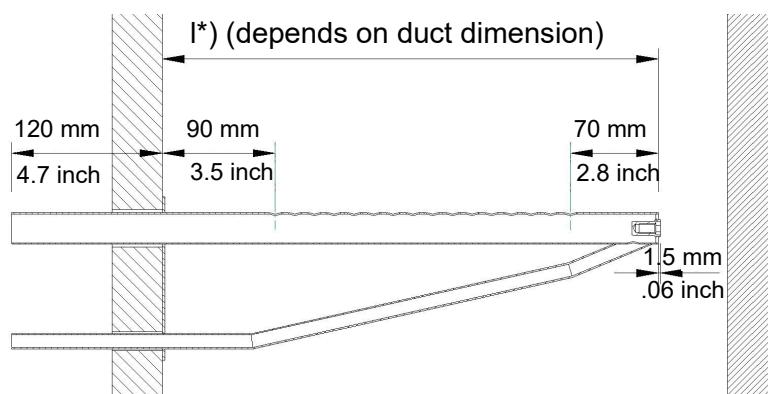

Please use the total height of the duct!

*) s. table of manifold lengths **Horizontal assembly position in duct**

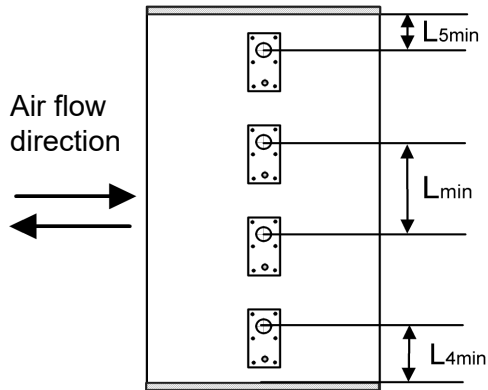

Minimum distance for condensation avoidance:

L_{min} = 210mm/8.3 inch: „Steam manifold - Next steam manifold“ distance

L_{4min} = 120mm/4.7 inch: „Lowest steam manifold - Duct bottom plane“ distance

L_{5min} = 120mm/4.7 inch: „Highest steam manifold - Duct ceiling plane“ distance

Steam manifold arrangement for special air duct shapings

flat	steam manifold laterally staggered (with respect to air flow direction) in case of L _{min} (s. above) not to be met	<p>A diagram showing three steam manifolds in a flat duct, staggered laterally. Dimensions include 200mm/7.9inch between manifolds, 100mm/3.9inch from the first manifold to the duct wall, and vertical clearances of 120mm/4.7inch, 270mm/10.6inch, and 430mm/16.9inch from the duct floor.</p>																
very flat	<p>by tilting the steam manifold 30 - 45° towards the air flow direction, the minimum upper clearance can be reduced to 70 mm/2.8 inch.</p> <table border="1" data-bbox="384 1429 906 1617"> <thead> <tr> <th>Min[mm/inch]</th> <th colspan="2">H1</th> <th>H2</th> </tr> <tr> <td></td> <th>30°</th> <th>45°</th> <td></td> </tr> </thead> <tbody> <tr> <td>DN25/1"</td> <td>182/7.2</td> <td>168/6.6</td> <td>225/8.6</td> </tr> <tr> <td>DN40/1 1/2"</td> <td>193/7.6</td> <td>179/7.2</td> <td>230/9.1</td> </tr> </tbody> </table>	Min[mm/inch]	H1		H2		30°	45°		DN25/1"	182/7.2	168/6.6	225/8.6	DN40/1 1/2"	193/7.6	179/7.2	230/9.1	<p>narrow channel</p> <p>A diagram showing a steam manifold tilted at 30-45 degrees in a narrow channel. The channel height is 120mm. The minimum clearance from the top wall is 70mm. Dimensions H1 and H2 are also indicated.</p>
Min[mm/inch]	H1		H2															
	30°	45°																
DN25/1"	182/7.2	168/6.6	225/8.6															
DN40/1 1/2"	193/7.6	179/7.2	230/9.1															
narrow, high	identical lengths one on top of the other, staggered laterally if possible																	
square	identical lengths, staggered vertically and laterally																	
low, very wide	facing each other																	

Vertical steam manifold installation

Steam manifold arrangement

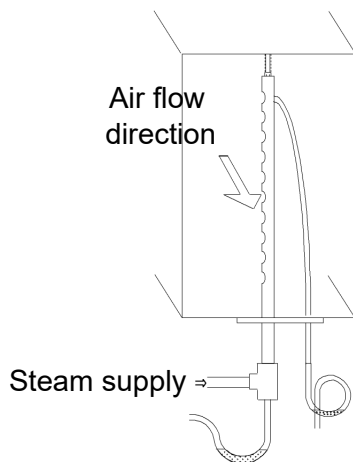

Horizontal installation of the steam manifolds is preferable. However, vertical installation into the air duct from below is also possible.

Standard manifold dimensions [mm]/ [inch]:**

220/ 8.7	400/ 15.7	600/ 23.6	900/ 35.4	1200/ 47.2	1450/ 57.1
---------------------	----------------------	----------------------	----------------------	-----------------------	-----------------------

*** Special lengths on demand.

Number and size of the steam manifolds available as well as the nominal diameter of the respective steam and condensate hoses may be taken from the tables shown in chapter „Technical Data“.

6. Water connection

▲ WARNING

Risk of scalding!

Very hot water to be found in and around the kit during and after operation.

Have all installation work done by expert staff in order to avoid scalding hazards due to improper water guidance.

▲ WARNING

Risk of electrical shock!

Hazardous electrical high voltage!

Before starting installation work ensure that the unit is not yet connected to the power supply.

General Rules

- Obey local water utility regulations
- Verify that necessary safety measures have been taken – in compliance with either German Technical and Scientific Association for Gas and Water (DVGW) guidelines (DIN EN1717) or local regulations – to eliminate backflow of polluted water into drinking water treatment facilities. This may require the installation of a system separator and free discharge into the drainage system
- Supply water must not exceed 40 °C (104 °F)
- Allowable range of water pressure: 100000 to 1000000 Pa (14.5 to 145 psi)
- For connection to the water supply pipe, make use of a water hose
- Blow-down water must drain freely
- Min. conductivity of the supply water must be 3 S/cm

6.1 Water supply

NOTICE

Foreign material in water supply pipe may cause premature wear of the solenoid valve.

Flush the water supply pipe before making connection to the solenoid valve. This is of particular importance in case of a newly installed pipe.

On-site, a shut-off valve and - if required by the water quality - a water filter in the supply line is to be installed. Use a connection hose with a 3/4" cap nut für connection to the water inlet (solenoid valve) of the kit.

Water pressure of the supply line is allowable from 1 to 10 bar (100×10^3 to 100×10^4 Pascal, 14.5 to 145 psi).

Please note

Strainer must be placed inside the solenoid valve.

6.2 Water discharge

▲ WARNING

Risk of scalding!

During blow down up to 0.3 l/sec (.08 gal./sec) are being drained with a temperature of about 95 °C (203 °F).

Ensure that the drain hose is reliably fastened and wastewater can drain freely and pressureless.

Please note

Humidifier kit installation location and wastewater discharge must be on the same pressure level.

Guidelines for water discharge composition

- Do not buckle drain hose
- Discharge line and drain pipe material must be temperature resistant up to 95 °C (203 °F)

How to proceed

- » Fit 14 mm (.55 inch) drain hose with a clamp to the wastewater connection and run into a pressure-free outlet according to DIN EN 1717.

6.3 Water connections final check

Go down the following water installation checklist:

- All screws and clamps properly tightened?
- Water supply line flushed before making connections?
- Water connection properly installed?
- Water discharge properly installed?
- Does blow-down water drain freely?
- Water supply line and water discharge leakage-free?

7. Electrical connection

⚠ WARNING

Danger of electrical shock!

Dangerous electrical voltage!

All work relating to the electrical installation may only be carried out by designated specialist personnel (electrician or qualified person with equivalent training).

Do not connect the steam humidifier to the live power supply before all installation work has been completed.

Please note

The customer is responsible for monitoring the qualifications of the specialist personnel.

General installation rules

- All local rules concerning the implementation of electrical installations must be obeyed
- Install the electrical connections according to the wiring diagram

NOTICE

Possible electronic components destruction through electrostatic discharge!

Prior to commencing electrical installation work, steps must be taken to guard the sensitive electronic components of the unit control against damage from electrostatic discharge.

7.1 Electrical installation approach

- » Provide fuses with a contact gap of at least 3mm per pole.
- » Make main connection according to the table below.

Main connections

Please refer to the table of technical data (see chapter at the end of this manual) for the connection values of the installation kits.

Fusing

HygroMatik recommends the use of slow blowing up to middle time-lag main fuses (only applies to the a.m. mains supply voltages).

Please note

The kit installation should incorporate an individual residual current device (Type A-RCD).

Maximum current draw of the kit models and the required fusing resulting from that can be found in the technical data (see chapter at the end of the manual).

7.2 Safety interlock

The descriptions following hereafter relate to the usage of a kit in combination **with a HygroMatik control**. If the kit is used without a control „Basic“ or „Standard“, it is the responsibility of the kit operator to implement a safety (interlock) system.

⚠ WARNING

Risk of electrical shock!

Hazardous electrical voltage!

When standard wiring was made, terminal 1 shows 208 - 240 VAC after commissioning.

Across terminal 1 and 2 the so-called safety interlock is wired. This wiring allows for integration of safety devices. In case of an open safety interlock the steam humidifier does not operate.

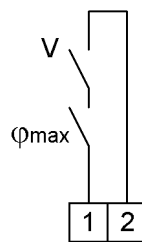

Safety interlock terminals 1/2

Please note

Factory setting leaves the safety interlock open!

Install contact interlocks, e.g. a max. hygrosat in series across terminal 1 and 2.

Please note

Contacts across terminals 1 and 2 must be potential free and rated for 240 VAC.

Best practice implies the integration of a max. hygrosat in the safety interlock wiring to protect against over-humidification due to a r.h. sensor malfunction.

7.3 Internal electrical connection

7.3.1 Overview

The customer is generally responsible for the electrical wiring of the kit. Three variants of setting-up a control are possible:

SteamKit H kit w/o HygroMatik control

Without a control logic, operation of the steam humidifier kit is possible by means of a simple control circuit. Section 7.4.1 depicts proposals for the wiring of such a circuit.

When unit enabling is present (e.g. via the S1b switch in combination with the simple control), the control of the steam production is achieved in a 1-step mode by the water level in the steam cylinder as signalled by the float switch. The float switch is part of the control cylinder included in the kit delivery scope.

SteamKit H kit in combination with the HygroMatik Control Standard

The control „Standard“ operates with all of the common control signals. It controls the steam production as well as the filling and blow-down processes. Continuous water level control is through evaluation of the water level sensor that is included in the control „Standard“ delivery scope as part of the control cylinder.

The control logic also comprises the error detection for the various functional areas.

7.3.2 Internal electrical connection w/ o HygroMatik control

Blow-down

For blowing-down the cylinder water, the blow-down interval should be set in a way that after 60 mins of steam production the pump runs for 7 secs.

When running the kit with tap water, increasing the number of blow-down cycles may enlarge the specific maintenance interval.

If required, pls. contact your expert dealer or HygroMatik for advice.

Control cylinder

The Steamkit-H kit is delivered with a control cylinder that holds a floating switch array consisting of reed switches for the stepped monitoring of the water level. Three levels are discriminated. The wire colours are assigned as follows:

Red - max. level

Orange - refilling

Black - dry level

Brown - phase L1

Please note

Included in the delivery scope is a varistor the usage of which is recommended for the smooth operation of the kit.

The varistor smoothes the load peaks impacting on the reed switches. The wiring (across the solenoid valve connections) is depicted in the interconnection diagram (s. section 7.4.1).

7.3.3 Internal Electrical Connection when the kit is delivered with a HygroMatik control

Use of Control Standard

Part of the delivery scope of the control is a level control for the continuous monitoring of the water level in the steam cylinder. Connection diagrams for the electrical interconnection of the kit with the Control Standard can be found in section 3.1.1 („Wiring diagrams“) of the respective manual.

7.4 Connection diagrams

In case of a HygroMatik Control Basic or Control Standard to be used with the kit, the device-specific wiring diagrams are included in the scope of delivery. Please use them for the installation and keep them in a safe place.

For all other types of application, the connection of the electrical components is the responsibility of the customer.

Following hereafter, pls. find 2 recommendations for setting up a simple control making use of the control cylinder supplied with the kits that are delivered without a HygroMatik control.

8. Commissioning

The descriptions given hereafter particularly relate to the usage of a kit with the Control Standard and - with the exemption of step 3 - Control Basic.

▲WARNING

Risk of operating error!

Start-up of the unit is restricted to expert staff only (electricians or expert personnel with equivalent training).

Step 1: Check of mechanical integrity and wiring

- » Check cylinder seating.
- » Check steam, condensate and drainhose clamps.
- » Check that all electrical wire connections (including steam cylinder wiring) are tight and secure.

Step 2: Switching on the steam humidifier

- » Switch on main breaker.
- » Open water supply stopcock (operating pressure should be 1bar min., 10bar max.).
- » Switch on unit by setting control switch to "I".

Step 3: The unit performs a self-test and, then, commences normal operation

- During self-test, the display flashes for a couple of seconds (only with Control Standard)
- On completion of the test, the software version is displayed for a short moment (only with Control Standard). Consequently, normal operation is commenced. However, steam is not produced

Step 4: Trigger steam demand

- » Set control to 1-step operation, i.e. permanent steam demand, and close safety interlock.
- The water inlet solenoid valve opens and feeds water into the steam cylinder

Step 5: Monitor unit function and check for leakage

- » Let unit operate for 15 to 30 minutes.
- » If leaks appear, switch off the unit.

▲WARNING

Risk of electrical shock!

Hazardous electrical voltage!

Follow safety instructions for work on live components.

Step 6: Repair leaks

- » Find leaks and eliminate.
- » Check again for leaks.

9. Maintenance

9.1 General

For the achievement of a long unit life span, regular maintenance is a must. Maintenance works to be performed refer to unit assemblies that underlie either mechanical or electrical wear and tear, or may be impeded by residues in their proper functioning.

The steam humidifier's performance and maintenance intervals primarily depend on the water quality encountered and the amount of steam produced. A particular water quality may shorten or lengthen maintenance intervals. The amount of residues found in the steam cylinder allows for a hint on future maintenance intervals.

As part of the maintenance work, screw terminals and plug connections must be checked every time. If required, retightening the terminal screws is a must as well as ensuring tight fit of all of the plug connections.

Since steam and condensate hoses are subject to wear as well, hoses must also be checked regularly.

Seals are wear parts. As such, seal integrity checks and replacement if required, is also a part of the regular maintenance work (s. spare parts section -> O-ring sets).

9.1.1 Safety instructions for maintenance

▲ WARNING

Risk of electrical shock!

Hazardous electrical voltage. Unit must be switched off and protected against restart by expert staff (electricians or expert personnel with equivalent training) before any maintenance work is commenced.

▲ WARNING

Risk of skin burning!

Hot steam cylinder during operation and for some time afterwards.

Drain steam cylinder before any maintenance work is commenced. After that, wait approx. 10 mins before starting maintenance work.

Check steam cylinder temperature by cautious approximation with hand (do not touch!).

▲ WARNING

Risk of scalding!

Water pumped or drained from the steam cylinder may have a temperature of up to 95 °C (203 °F).

Wear proper PPE (Personal Protection Equipment)!

The notice following hereafter is of particular significance when a HygroMatik control is used. It is a general rule, however, whenever electronic components are in use.

NOTICE

Take care of ESD protection!

The electronic components of the humidifier control are very sensitive to electrostatic discharges. In order to protect these components during maintenance, steps must be taken to guard against damage from electrostatic discharge.

9.2 Maintenance frame work when unit is operated with fully demin. water and condensate

Instructions on maintenance and cleaning intervals are entirely based on empirical data.

Cycle time	Maintenance work
<p>4 weeks after commissioning (also after installation of a new steam cylinder)</p>	<ul style="list-style-type: none"> • Visual inspection of electrical and mechanical connections • Remove mineral deposits from steam cylinder, water drain hose and blow-down pump • Visual inspection of level control. • Visual inspection of the steam cylinder interior.
<p>annually</p>	<ul style="list-style-type: none"> • Visual inspection of electrical and mechanical connections • Remove mineral deposits from steam cylinder, water drain hose and blow-down pump. • Visual inspection of level control. • Visual inspection of the steam cylinder interior. • Removal of used O-rings between the cylinder halves, in the base and in the steam hose adapter • Cleaning the vent hole in the pipe bend • Cleaning the fine filter of the solenoid valve • Checking the hoses

9.3 Maintenance when unit is operated with tap water or partially softened water

No precise maintenance intervals can be specified because these always depend on water quality and the amount of steam generated. It is advisable to adjust the frequency of maintenance to the specific operational experience. HygroMatik recommends to check the opened steam cylinder 1 or 2 weeks after initial commissioning in order to quantify the amount of residue produced so far, allowing for determining future maintenance intervals and/or the adjustment of blow-down cycles possibly required.

Blow-down cycles

The vaporisation process causes hardness builders (calcium) in form of solids of various compositions to fall out within the steam cylinder. Cyclic blow-down by means of a powerful blow-down pump followed by fresh water refills remove parts of this solid built-up.

Water quality

When tap water is used, it must be taken into account that cleaning intervals shorten as the carbonate hardness level increases. As a general rule, it is preferable to operate the unit with fully demineralized water since operation will not be affected by mineral deposits and flushing loss will be minimized.

Please note

Possibly, maintenance intervals may be extended by moderately increasing the blow-down cycle rate. Please consult your expert dealer.

9.4 Maintenance steps

9.4.1 Removal of the steam cylinder

- » Drain cylinder water making use of blow-down pump.
- » Disconnect unit from power supply and secure against reconnection.
- » Shut off the water supply.

- » Wait 10 minutes so that the possibly hot cylinder can cool down.

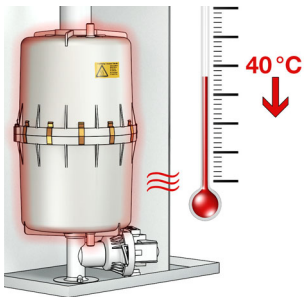

- » Check the temperature by carefully approaching it with your hand, do not touch the cylinder if the rest heat should be too strong.

- » Remove the steam hose from the steam hose adapter.

- » Separate connector halves.

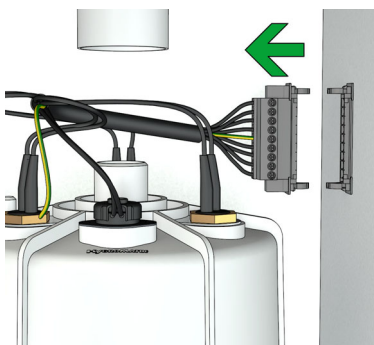

- » Lift steam the cylinder from the cylinder base.

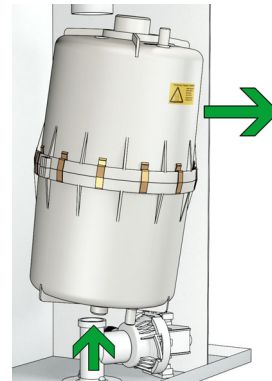

9.4.2 Cylinder cleaning / O-ring replacement

For cleaning, mechanical removal of the deposits is usually sufficient.

CAUTION

Risk of eye injuries!

The clips that fix the steam cylinder halves have sharp edges and can jump off during dismantling.

Eye injuries are possible.

Wear proper PPE (Personal Protection Equipment)!

- » Remove the cylinder flange clamps.

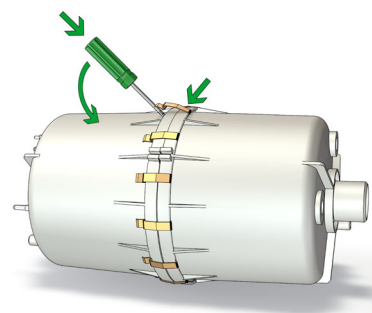

- » Separate cylinder halves.

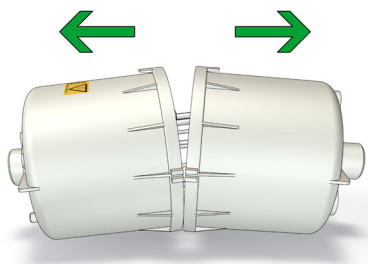

- » Remove the used O-rings between the cylinder halves, in the base and in the steam hose adapter.

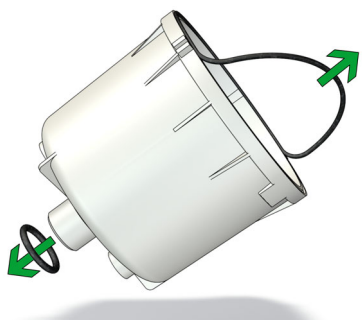

- » Clean the cylinder inside.



- » Clean the heating element(s) by scraping or scrubbing. A small amount of scale hardener is harmless.

- » Clean both strainer.

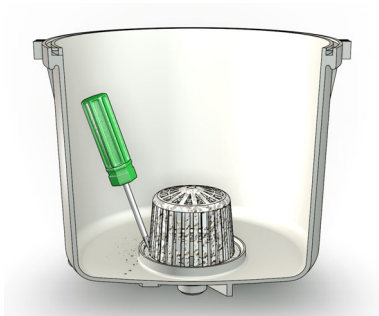

- » Check the base and its connections for limescale deposits and clean if necessary.

- » Insert new O-rings between the cylinder halves, in the base and in the steam hose adapter.

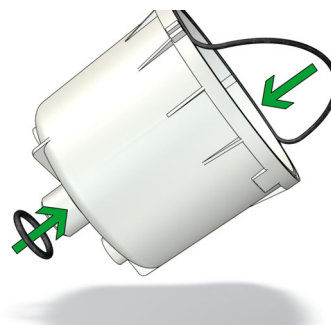

- » Put the cylinder halves together and reconnect them with the flange clamps.

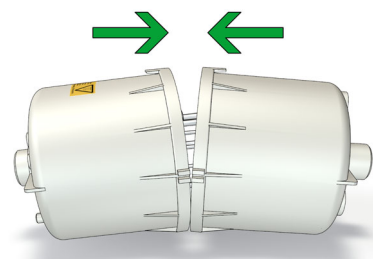

- » When assembling the cylinder, make sure that the brackets and reinforcements are on top of each other.

NOTICE

Risk of functional disruption!

Use descaler or cleaning detergents only for cylinder and heater element cleaning. Do not introduce in cylinder base or apply to hoses!

Prior to restarting the unit, make sure that the device assemblies in question are thoroughly flushed or rinsed.

Possible damage to the unit!

Excessive use of force during mechanical cleaning of the cylinder or heating element can damage these parts of the unit.

9.4.3 Cleaning the connecting hoses, base connections, fine filter and drain pump

- » Check the connection hoses for condition and free passage.
- » Check all connections of the cylinder base for free passage.
- » Clean the hoses and connections if necessary.
- » Remove the fine filter on the water connection side from the solenoid valve and clean it under running water.
- » Clean the drain pump as described in the section of the same name.

NOTICE

When operating with partially softened water or tap water, scale may be discharged with the steam flow and may settle in the nozzle positioned in steam hose adapter. Therefore, this nozzle should be inspected regularly as part of the general maintenance review and cleaned if necessary.

9.4.4 Level control device cleaning

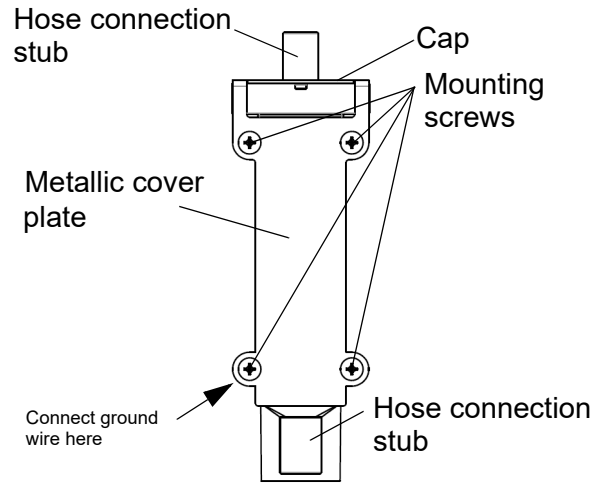

Water sensor

The level control device is accessible only after removal of the steam cylinder.

- » Disconnect hoses from level control device connection stubs on upper and lower side
- » Remove the 4 screws securing the metallic cover plate of the level control device and the device as such against the unit rear wall. Memorize ground wire attachment position (under lower left hand side screw).
- » Unclip level control device enclosure cap with a flick of the thumb and remove.
- » Take out o-ring and dispose of.
- » Make visual inspection of level control device enclosure interior and clean, if required. Scratch out any deposits, if present.
- » Inspect both level control connection hoses and clean, if required.
- » Insert new o-ring.
- » Re-attach enclosure cap.
- » Align metallic plate with level control device enclosure mounting holes and insert screws in upper left and lower right position. Reintroduce level control device into humidifier housing and loosely affix to unit rear wall with the 2 screws.

9.4.5 Cleaning the vent hole on the pipe elbow

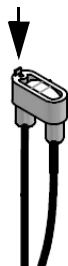

- » Check the small opening on the top of the pipe elbow for dirt.
- » Remove any dirt, e.g. with a small screwdriver.
- » Follow the handling instructions in the section **Leakage test**.

Please note

The vent hole should be checked for free circulation during every maintenance. A blocked vent hole has a negative effect on the drainage process (see also chapter "Trouble shooting" in the manual of the control).

9.4.6 Reinstallation of the steam cylinder

- » Place the cylinder vertically in cylinder base.

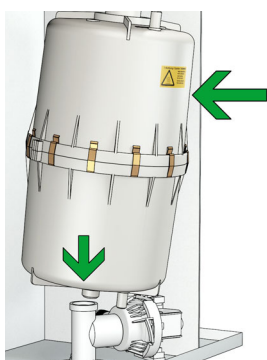

- » Reconnect connector halves.

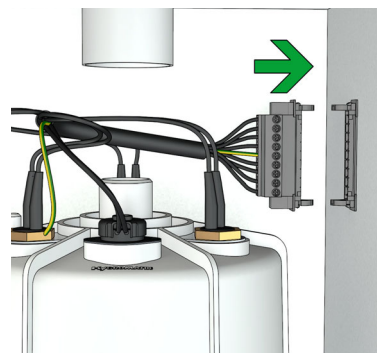

Please note

The colour of the respective connection cable must match the colour of the respective electrode hand nut.

- » Check all cabling screw terminals and plugs for tight seating. Plugs must sit on their respective contacts as far as they will go.
- » Check electrode plugs for corrosion. Replace, if stained.

NOTICE

Risk of functional disruption!
Risk of material damage!

Loose cable connections may result in increased transition resistance and contact area overheating.

- » Check all cabling terminals and plugs for tight seating. Plugs must sit on their respective contacts as far as they will go.
- » Check heater element wiring for damaged insulation

- » Reattach Super Flush solenoid hose (if applicable) to steam cylinder bottom stub.
- » Attach steam hose adapter to cylinder.
- » Follow the handling instructions in the section **Leakage test**.

9.5 Removal and installation of unit components

- » Refit electrical cable to pump connector (no polarisation).
- » Follow the handling instructions in the section **Leakage test**.

9.6 Blow-down pump (removal, cleaning, reinstallation)

Removal and cleaning

- » Remove steam cylinder as described in „Removal of steam cylinder“ section.
- » Detach adapter (30) from pump (32).
- » Detach electrical cable from pump.
- » Remove nuts securing pump on console bottom plate.
- » Remove cap nuts securing cylinder base ((37) in exploded view).
- » Remove pump and cylinder base from console and separate.
- » Open pump bayonet lock.
- » Remove residues from pump and drain hoses (replace O-ring (34) if required).

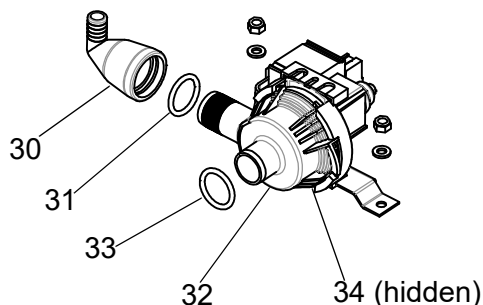

Reinstallation

- » Moisten O-ring (33) and insert into cylinder base (37) horizontal stub.
- » Push pump back into cylinder base and position the combination of pump and base on the stud bolts of the console.
- » Reattach cap nuts (cylinder base) and nuts (pump).
- » Moisten O-ring (31) and insert into adapter.
- » Slide adapter (30) onto pump stub.

9.6.1 Solenoid valve (removal, reinstallation)

Removal

- » Shut off water supply and disconnect tap water hose cap screw connection.
- » Remove connecting hose (20*) from cylinder base.
- » Detach electrical cable connector from solenoid valve (25*).
- » Unscrew solenoid valve mounting screws.
- » Remove solenoid valve from housing bore.

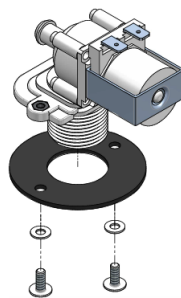

Reinstallation

- » Reinsert fine filter into solenoid valve.
- » Reinsert solenoid valve with seal in unit housing bore.
- » Bolt-down solenoid valve.
- » Re-establish tap water connection.
- » Reconnect electrical cable to solenoid valve.
- » Reattach connecting hose (20) to cylinder base using clamp.
- » Follow the handling instructions in the section **Leakage test**.

*) the numbers refer to the exploded view in the same named chapter

9.7 Leak test

⚠ WARNING

Risk of electrical shock!

Hazardous electrical voltage!

Follow safety instruction for work on live components.

Leakages may invoke leak currents.

The leak test described below must be done after all maintenance work that affects the water circuit inside the unit. If work has been done at several points, the final leak test is enough, although this work step is listed for all parts of the work.

The leak test must be done with the unit open, paying particular attention to the warning above.

- » Open the water supply.
- » Switch on the unit and check the inside for leaks (hose connections, O-rings, seals) after 15-30 minutes of operation.
- » In case of leakage turn off power supply and secure against being switched on again.
- » Find leakage and eliminate.
- » Check again.
- » Follow the instructions in the section **funktional check**.

9.8 Functional check

- » Run the system with maximum output for a couple of minutes
- » Check hose connections and seals for leakage.

10. Dismantling

Once the steam humidifier will no longer be used, dismantle (demolish or scrap) it by following the installation procedures in reverse order.

▲ WARNING

Dismantling of the unit may only be performed by qualified personnel. Electrical dismantling may only be performed by trained electricians.

Disposal after dismantling

The humidifier is made up of metal parts and plastic parts. In reference to European Union directive 2012/19/EU issued on 4 July 2012 and the related national legislation, please note that:

The components of the electrical and electronic devices must not be disposed of as municipal waste, and therefore the method of waste separation must be applied. The public or private waste collection systems defined by local legislation must be used.

NOTICE

The operator is responsible for the disposal of unit components as required by law.

11. Spare parts

*	KitH02	KitH03	KitH06	KitH09	KitH15	KitH25	KitH30	KitH40	KitH50	Article No.	Description
Steam generation 208 - 240 V											
16	1									SP-01-01010	Steam cylinder KitH02 CY08 208-240V, compl. incl. O-ringset
16		1								SP-03-01010	Steam cylinder KitH03 CY08 208-240V, compl. incl. O-ringset
16			1							SP-03-01040	Steam cylinder KitH06 CY08 208-240V, compl. incl. O-ringset
16					1					SP-04-01010	Steam cylinder KitH15 CY08 208-240 V, compl. incl. O-ringset
							1			SP-06-01070	Steam cylinder KitH30 CY08 208-240 V, compl. incl. O-ringset
4	1									B-2209031	Heating element CY02 2kg 208-240 V, incl. gaskets
4		1								SP-03-01100	Heating element CY08 3kg 230V, incl. gaskets
4			1							SP-03-01101	Heating element CY08 6kg 230V, incl. gaskets
4					3		6			SP-07-01100	Heating element CY17 5kg 208-240 V, incl. gasket
Steam generation 380 - 480 V											
16			1							SP-03-01041	Steam cylinder KitH06 CY08 380-415V, compl. incl. O-ringset
16				1						SP-03-01070	Steam cylinder KitH09 CY08 380-415V, compl. incl. O-ringset
16					1					SP-04-01011	Steam cylinder KitH15 CY17 380-415V, compl. incl. O-ringset
16						1				SP-04-01040	Steam cylinder KitH25 CY17 380-415V, compl. incl. O-ringset
							1			SP-06-01071	Steam cylinder KitH30 CY17 380-415V, compl. incl. O-ringset
								1		SP-06-01010	Steam cylinder KitH40 CY17 380-415V, compl. incl. O-ringset
									1	SP-06-01040	Steam cylinder KitH50 CY17 380-415V, compl. incl. O-ringset
4			1							SP-03-01102	Heating element CY08 6kg 400V, incl. gaskets
4				1						SP-03-01105	Heating element CY08 9kg 400V, incl. gaskets
4					3		6	3		SP-07-01101	Heating element CY17 5kg 400V, incl. gasket
4						3		3	6	SP-07-01104	Heating element CY17 8,4kg 400V, incl. gasket
Steam generation 440 - 480 V											
16			1							SP-03-01042	Steam cylinder KitH06 CY08 440-480 V, compl. incl. O-ringset
16				1						SP-03-01071	Steam cylinder KitH09 CY08 440-480 V, compl. incl. O-ringset
16					1					SP-04-01012	Steam cylinder KitH15 CY08 440-480 V, compl. incl. O-ringset
16						1				SP-04-01041	Steam cylinder KitH25 CY08 440-480 V, compl. incl. O-ringset
							1			SP-06-01072	Steam cylinder KitH30 CY08 440-480 V, compl. incl. O-ringset
								1		SP-06-01011	Steam cylinder KitH40 CY08 440-480 V, compl. incl. O-ringset
									1	SP-06-01041	Steam cylinder KitH50 CY08 440-480 V, compl. incl. O-ringset
4			1							SP-03-01103	Heating element CY08 6kg 440-480 V, incl. Gaskets
4				1						SP-03-01107	Heating element CY08 9kg 440-480 V, incl. Gaskets
4					3		6	3		SP-07-01102	Heating element CY17 5kg 440-480 V, incl. Gaskets
4						3		3	6	SP-07-01105	Heating element CY17 8,4kg 440-480 V, incl. Gaskets
Steam generation general											
	1									AC-01-01000	O-ringset (pos. 3, 17, 31, 18, 33, 34, 35)
		1	1	1						AC-03-01000	O-ringset (pos. 3, 17, 18, 31, 33, 34, 35)
					1	1				AC-04-01000	O-ringset (pos. 3, 17, 18, 31, 33, 34, 35)
							1	1	1	AC-06-01000	O-ringset (pos. 3, 17, 18, 31, 33, 34, 35)
18	1	1	1	1	1	1	1	1	1	B-3216021	Cylinder flange clamps, set=24pcs
5	1	1	1	1	1	1	2	2	2	B-2205031	Thermal circuit breaker steam cylinder incl. incl. gasket, clips
	1									B-2209035	Protective tube incl. melting fuse
27	1	1	1	1	1	1	1	1	1	CN-07-01010	Water level sensor complete for Control Standard
60	1	1	1	1	1	1	1	1	1	B-2504171	Float switch w/o housing for Control Basic
60	1	1	1	1	1	1	1	1	1	B-2504173	Float switch w/o housing for simple control
1	1									E-3221002	Adaptor for steam hose for cylinder CY08 DN25
1		1	1	1	1	1				E-2209018	Adapter for Steam hose for cylinder CY08 DN40-25
1							2	2	2	E-2209008	Adapter for Steam hose for cylinder CY17/45 DN40-40
37	1	1	1	1						E-3220000	Cylinder base
37					1	1	1	1	1	E-2206086	Cylinder base
Water feed											
25	1	1	1	1						B-2304251	Solenoid valve KitH03-09 208-240V 0.2 - 10bar with mounting set
25					1	1				B-2304253	Solenoid valve KitH15-25 208-240V 0.2 - 10bar with mounting set
							1	1	1	B-2304257	Solenoid valve KitH15-25 208-240V 0.2 - 10bar with mounting set
	1	1	1	1	1	1				auf Anfrage	Water feed group incl. clamps (pos. 21, 22, 24, 37)
Water drain											
	1	1	1	1						B-2425005	Pump-drain-hose-system (pos. 6, 14, 15, 30, 31)
					1	1	1	1	1	B-2425009	Pump-drain-hose-system (pos. 6, 14, 15, 30, 31)
	1	1	1	1	1	1	1	1	1	B-2404027	Drain pump without mounting set, with 2 o-rings

*) relates to position no. in exploded view

Spare Parts (continued)

*)	KitH02	KitH03	KitH06	KitH09	KitH15	KitH25	KitH30	KitH40	KitH50	Article No.	Description
											Electrics
	1	1	1	1						CN-03-01000	Solid state relay incl. heatsink
					1	1	1	1	1	CN-07-01000	Solid state relay incl. heatsink
	1	1	1							WR-03-01000	Connector e-compartment - water compartment, plug + socket
				1	1	1	2	2	2	WR-07-01000	Connector e-compartment - water compartment, plug + socket
	1	1	1	1	1	1	1	1	1	CN-07-00000	Control Standard Mainboard
	1	1	1	1	1	1	1	1	1	E-0510010	Display
	2	2	2	2	2	2	2	2	2	E-0510012	Clip for display
	1	1	1	1	1	1	1	1	1	E-2502412	Control switch, double pole, middle position = "0"
											Accessories
										E-2604012	Steam hose DN25, per m
										E-2604013	Steam hose DN40, per m
										E-2604002	Condensate hose DN12, per m
										E-2604004	Condensate hose DN14, per m
										E-2404004	Steam hose clamp DN25
										E-2604016	Steam hose clamp DN40
										E-2304015	Condensate hose clamp DN12
										E-8501064	Condensate hose clamp DN14
										E-2604042	Connectors for steam distribution T-piece DN25, stainless steel
										E-2604023	Connectors for steam distribution T-piece DN40, stainless steel
										E-2604021	Connectors for condensate T-piece DN12

*) relates to position no. in exploded view

For ordering spare parts, a template can be found on the www.hygromatik.com website under the „Contact“ tab. Your spare parts order may as well be directed per e-mail to the HygroMatik main office using the address hy@hygromatik.de.

Please make sure to specify your unit model and serial number.

12. Exploded view

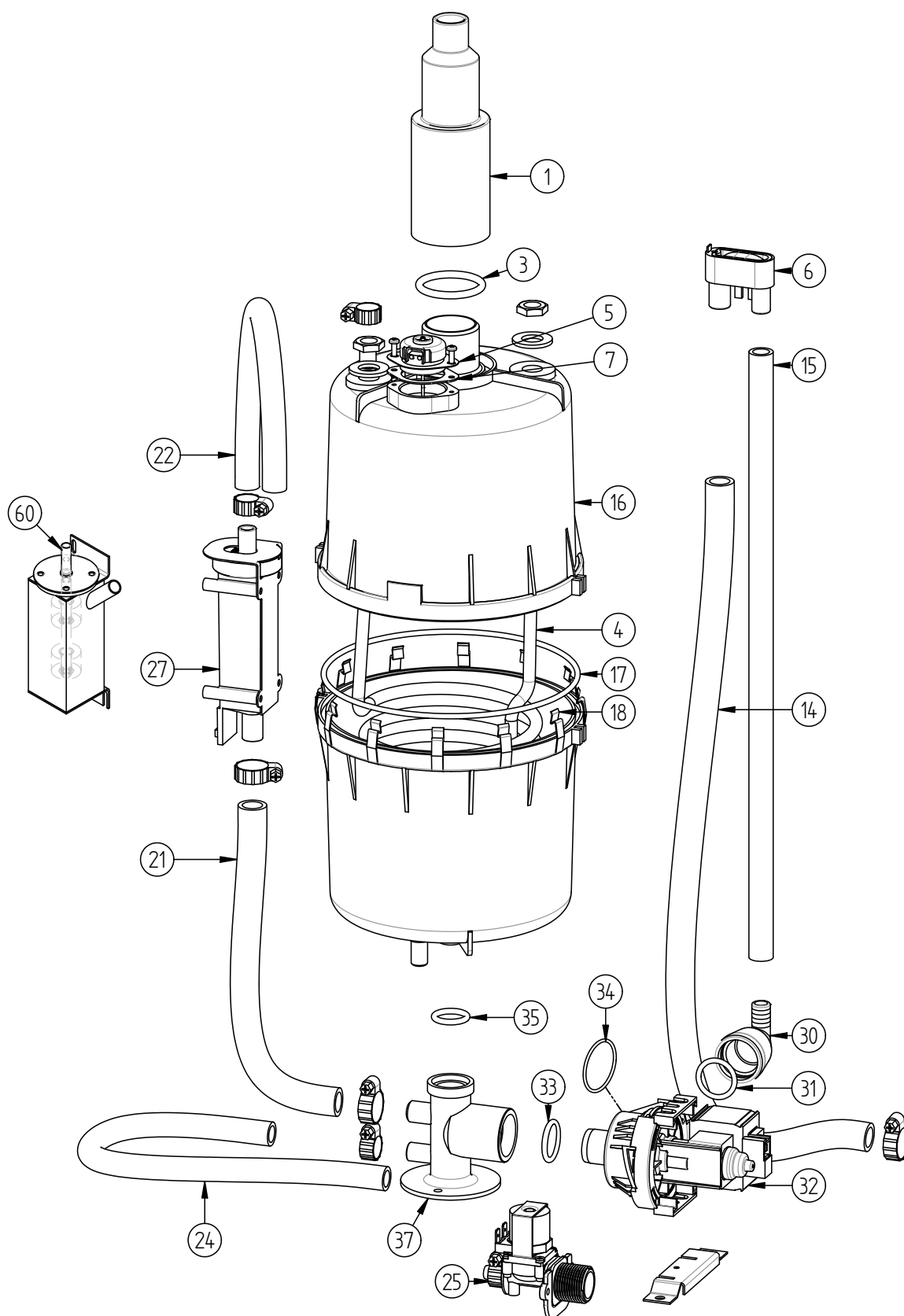

This page intentionally left blank

This page intentionally left blank

This page intentionally left blank

13. Technical specifications

Technical data SteamKit H (Heater)					
Unit type	KIT H02	KIT H03	KIT H06		KIT H09
Steam output [kg/h]	1,8 - 2,2	2,7 - 3,3	5,5 - 6,5	5,4 - 6,5	8,1 - 9,7
Electrical connection ⁽¹⁾	220 - 240V / 1Ph / N / 50-60Hz			380 - 415V / 3Ph / N / 50-60Hz	
Rated power [kW]	1,4 - 1,6	2,1 - 2,4	4,1 - 4,9	4,1 - 4,8	6,1 - 7,3
Nominal current [A]	6,2 - 6,8	9,4 - 10,2	18,7 - 20,4	10,7 - 11,7	16 - 17,5
Fuse [A]	1 x 10	1 x 16	1 x 25	3 x 16	3 x 20
Control	optional: Standard				
Control voltage	220 - 240V / 1,6A				
Steam hose connection [mm]	1 x 25				
Water consumption ⁽⁷⁾ [l/h]	2,6	4	7,8		11,7
Water flow rate ⁽⁸⁾ [l/min]	1,3				
Max. filling capacity [l]	3,1				4,8
Empty weight [kg]	4,5				5,4
Operation weight [kg]	9				11
Width [mm]	300				
Height [mm]	400				550
Depth [mm]	220				
Water connection	fully demineralised water / cleaned condensate / partially softened tap water of varying qualities / 1 to 10 bar, 3/4" external thread				
Drain water connection	Connection Ø 1 1/4"				

Technical data SteamKit H (Heater)					
Unit type	KIT H15	KIT H25	KIT H30	KIT H40	KIT H50
Steam output [kg/h]	13,7 - 16,4	22,7 - 27,1	27,4 - 32,7	36,5 - 43,5	45,5 - 54,3
Electrical connection ⁽¹⁾					
Rated power [kW]	10,3 - 12,3	17,1 - 20,3	20,6 - 24,5	27,3 - 32,6	34,1 - 40,7
Nominal current [A]	15,6 - 17,1	25,9 - 28,3	31,2 - 34,1	41,5 - 45,4	51,8 - 56,6
Fuse [A]		3 x 32	3 x 35	3 x 50	3 x 63
Control	optional: Standard				
Control voltage	220 - 240V / 1,6A				
Steam hose connection [mm]		1 x 40	2 x 40		
Water consumption ⁽⁷⁾ [l/h]	19,5	32,5	39	52	65
Water flow rate ⁽⁸⁾ [l/min]	2,8		4,1		
Max. filling capacity [l]	14		36		
Empty weight [kg]	9		16		
Operation weight [kg]	24		52		
Width [mm]	350		420		
Height [mm]	700		785		
Depth [mm]	285		400		
Water connection	fully demineralised water / cleaned condensate / partially softened tap water of varying qualities / 1 to 10 bar, 3/4" external thread				
Drain water connection	Connection Ø 1 1/4"				

⁽¹⁾ Other voltages on request

⁽⁸⁾ Flow rate of feed water during refilling.

⁽⁷⁾ Maximum water consumption at 100% demand plus blow down losses.
Water consumption depends on the water quality and options installed.

HygroMATIK®

Lise-Meitner-Str.3 • D-24558 Henstedt-Ulzburg
TelefonPhone +49(0)04193/ 895-0 • Fax -33
eMail hy@hygromatik.de • www.hygromatik.de
member of **CAREL group**

