

Hygromatik Electric Actuator E - 4111680 for Spirax Sarco Valves

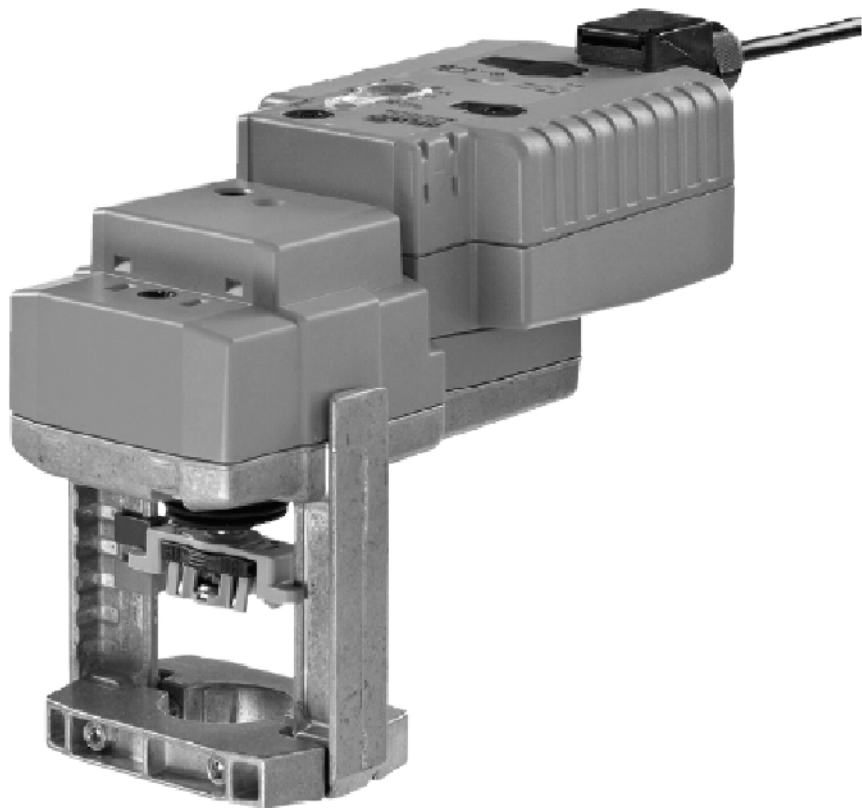

- Safety Instructions
- Composition/Setting up
- Electrical wiring
- Functional elements
- Dimensions
- Technical specifications

Safety instructions

The device is a CE product. Requirements according to 2004/108/EG are met.

The device is not safe against electromagnetic radiation according to EN 50082-1 in case of:

- the device or its wiring located close to transmission equipment.
- mains supply subject to extremely high interference
- a mobile broadcast receiver operated within a 3 m distance from the device or its wiring. Minimum distance heavily depends on the power output of the equipment in question.

Main supply rails featuring heavy noise must be supplied with protective gear such as filters, suppressor elements, surge limiters and peak noise limiters.

Mounting, repair and disposal instructions

- Mounting the device may only be carried out by trained expert staff. Legal and regulatory instructions must be obeyed.
- The device does not include any parts that may be changed or repaired by the user.
- The device includes electrical and electronic components and must not be disposed of as household garbage. Valid regional law must be obeyed.

Instructions for electrical wiring

The actuator design guarantees a high degree of safety for the user. Nevertheless, the following safety regulations must always be taken into account:

- Service staff must be trained for working with equipment that incorporates danger-to-life voltages.
- Correct wiring is a must. Safety must be ensured even when the actual wiring diverges from this mounting and operating manual.
- Before opening the housing it must be made sure that no supply voltage is present.

The actuator is a protection class III device. Excess current and isolation protection guarantee a reliable usage in building installations.

All external circuits must meet the IEC 364 requirements.

The actuator system must be supplied with a shut-off device located in the close proximity of the actuator. Service staff must be in the position of shutting-off the system without delay.

The following is to be considered:

- contact distance must be at least 3 mm
- the actuator shut-off device must be labeled as such
- protection ground must not be intersected
- the shut-off device must not be installed within the mains supply
- for shut-off device requirements see IEC 947-1 and IEC 947-3 or equivalent

The actuator must be located in a way that it is easily accessible.

Composition/Setting up

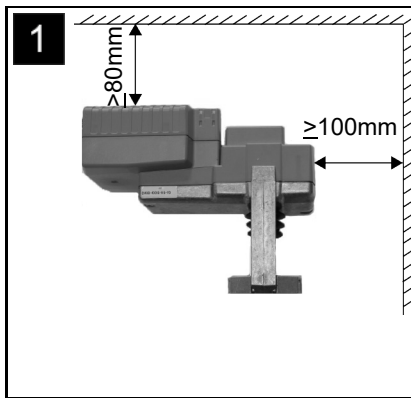

Observe minimum distance to surrounding objects. In case of disregard a built-up in temperature may occur. Also, dismantling of the device may be obstructed.

The steps described below for mechanical composition are only required in case of e.g. a valve to be exchanged. When ordering a complete DDS steam injection humidifier the valve and the actuator are already connected to each other.

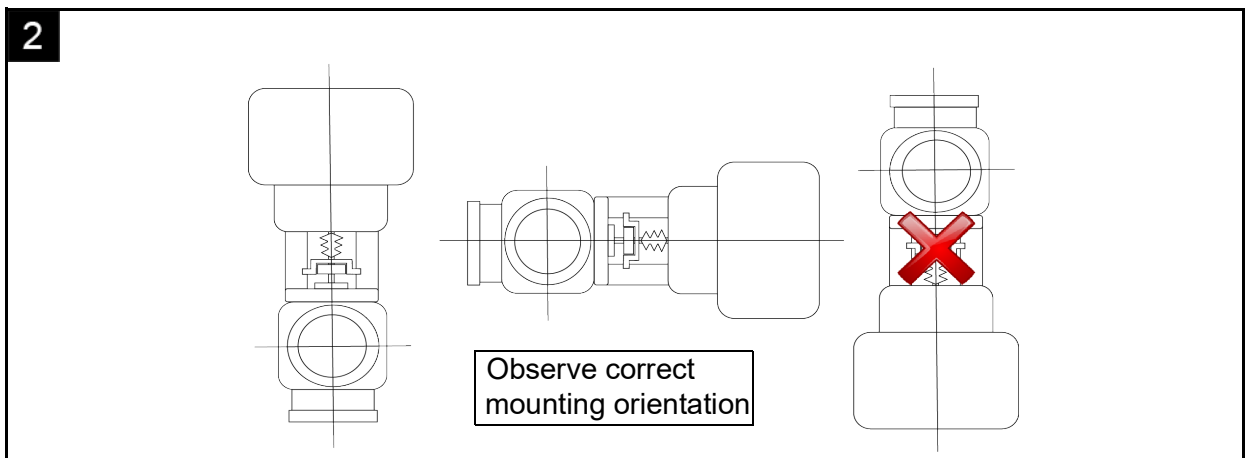

Before mounting the bonnet adapter on the valve neck any bonnet nut in place must be dismantled. Clean the thread but do not grease.

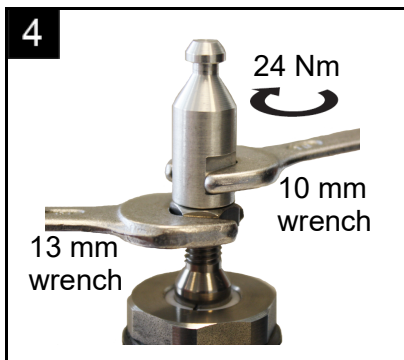

The adapter plunger is to be screwed onto the valve lifting rod and secured with a nut (24 Nm torque). The adjustment measure is given in the figure below (showing a valve lifting rod with a bonnet adapter already in place). Before making the adjustment the valve lifting rod must be fully pushed into the valve housing. For securing the plunger and the counter nut wrenches with 10 mm and 13 mm width across flats are required.

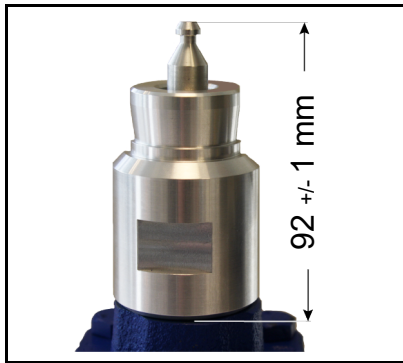

Adjustment measure for setting the adapter plunger (shown with bonnet adapter already in place).

Pls note: valve lifting rod with adapter plunger must be fully pushed into valve housing before making measurement



» Screw on adapter on valve bonnet and fasten with a 41 mm width across flats wrench (set torque to 40 Nm).

Mounting the actuator on the valve bonnet adapter

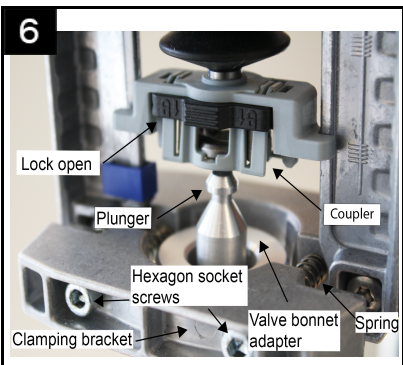

» Loosen the two hexagon socket screws using a 4 mm key until the clamping bracket has opened to an extent that allows for sliding it onto the valve bonnet adapter.

» Gently push the actuator onto the valve bonnet adapter until it comes to a rest on the stop.

» Tighten the hexagon socket screws with 10 Nm torque for clamping the mounting bracket on the valve bonnet adapter.

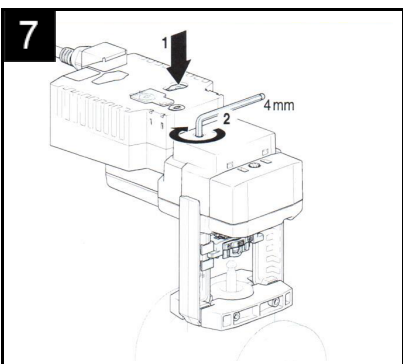

» Press key (7) on the control panel (see page 7) in order to achieve gear disengagement (step 1).

» While holding key (7) extend the lifting rod until the plunger latches in the coupler. Extending the rod is achieved by turning the manual override hexagon socket with a 4 mm hexagon socket key (step 2). In case of the lock not fully open push it up towards the stop before sliding the coupler over the plunger.

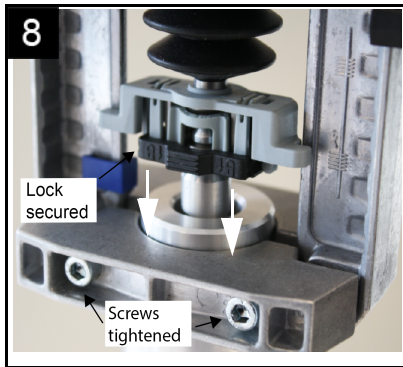

» Push the coupler lock downwards in the direction of the arrows in order to secure the connection.

Electrical wiring



Warning: When making electrical connections be sure that all cabling is fully de-energized.

AC/DC 24V continuous

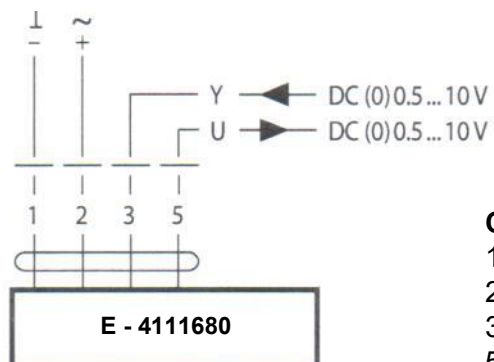

Cable colours:

- 1 = black
- 2 = red
- 3 = white
- 5 = orange

Use appropriate tools for making connections. Cable cross section required is 0.75 mm².

- Terminal 1: 0V
- Terminal 2: 24 V AC/DC
- Terminal 3: (0) 0.5...10V control signal
- Terminal 5: (0) 0.5...10V position feedback

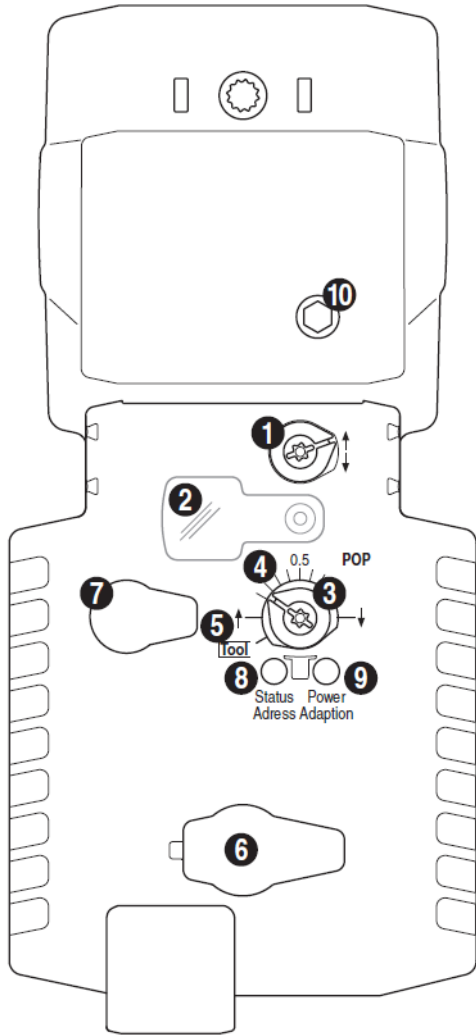

Display and control elements

- (1) **Direction of stroke switch**
Switch over: Direction of stroke changes
- (2) **Cover, POP button**
- (3) **POP button** (POP = Power-Off-Position)
- (4) **Scale for manual adjustment**
- (5) **Position for adjustment with tool**
- (6) **Service plug**
for parameterisation and service tools
- (7) **Gear disengagement button**
Press button: Gear disengaged, motor stops, manual override possible
Release button: Gear engaged, standard mode
- (8) **Push-button (LED yellow)**
Press button: Confirmation of addressing
- (9) **Push-button (LED green)**
Press button:
Triggers stroke adaption, followed by standard mode
- (10) **Manual Override**
Clockwise:
Actuator spindle extends
Counterclockwise:
Actuator spindle retracts

Meaning/function of LED displays

LED yellow (8)	LED green (9)	Meaning/function
Off	On	Operation OK
Off	Flashing	POP-Funktion aktiv
On	Off	Pre-charging time SuperCap Fault SuperCap wiring error in supply
Off	Off	Not in operation
On	On	Adaption process active
Flickering	On	Communication active

Explanation of the functions and control elements

Delivery condition

Delivery of the unit is with fully retracted lifting rod. The capacitors implemented for power interruption bridging require approximately 20 s of pre-charging time. The direction of stroke may be changed with the according switch on the control panel.

When start-up (first-time power-on) is carried out the actuator will perform a stroke adaptation cycle (see below) during which operating range and position feedback will adapt to the mechanical setting range.

The actuator is overload protected, requires no limit switches and automatically stops when the end stop is reached.

Direction of stroke switch

When actuated, the direction of stroke switch (1) changes the running direction in normal operation. It has no influence on the emergency setting position (POP) which has been set.

Emergency setting (POP button)

The turning knob „POP button“ (3) allows the manual setting of the emergency position desired (Power-off-Position, POP) in 10 percent steps in the range from 0 to 100 percent (scale see (4)).

The percentage refers to the height of stroke set. The emergency position is moved to when an electricity interruption of more than 2 s occurs (setting may be changed to up to 10 s using the MFT-P service tool). Any interruption shorter than the value set will cause the actuator to stop at the current position.

Please note: In the „Tool“ position (5) of the turning knob the emergency position setting made with the MFT-P service tool will be effective.

Manual override (gear disengagement)

For a temporarily manual operation of the stroke spindle the „Gear disengagement“ button (7) must be depressed and hold. The gear is then disengaged and the actuator is decoupled as long as the button is pressed. The motor stops. The stroke can be adjusted by using a hexagon socket screw key (4 mm) which is inserted into the top of the actuator. The stroke spindle extends when the key is rotated clockwise and vice versa.

On release of the gear disengagement button (7) normal operation is re-assumed.

Confirmation of addressing

This function is not used here. For LED (yellow) status explanation pls. refer to the table below.

Stroke adaption

A automatic adaption of the stroke spindle to the valve plunger mechanical displacement can be triggered manually by pressing the „Adaption“ button (9) (or with the PC-tool). Both mechanical end stops (blue and red) are detected during the adaption.

Following the adaption the actuator will return to normal operation, i.e. the spindle position is determined by the control signal.

For LED (green) status explanation pls. refer to the table below.

Dimensions

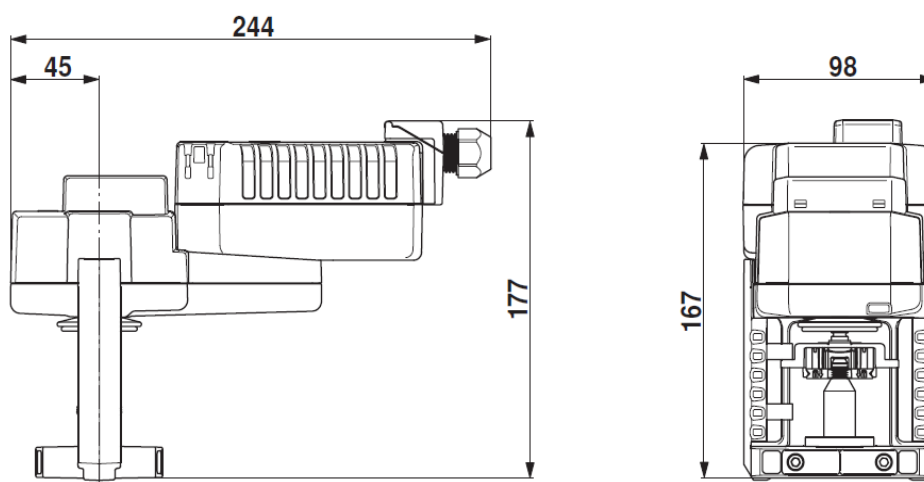

All measures in mm

Technical specifications

	Technical Data
Electrical data	
Nominal voltage	AC/DC 24
Nominal voltage frequency [Hz]	50/60 H
Nominal voltage range [V]	AC 19.2 ... 28.8 / DC 21.6 ... 28,8
Power consumption in operation [W]	2,5
Power consumption in rest position [W]	1,5
Power consumption for wire sizing [VA]	6
Connection supply / control [mm ²]	Terminal: 4 / cable: 4 x 0,75
Parallel operation	Ja
Functional data	
actuating force [N]	1000 N
Positioning signal Y [V]	DC 0...10
Positioning signal Y note [kΩ]	Input impedance 100
Operation range Y [V]	DC 0,5...10
Operation range Y variable [V]	Start point DC 0,5...30 / end point DC 2,5...32
Position feedback U [V]	DC 0,5...10
Position feedback U note [mA]	max. 0,5
Position feedback U variable [V]	Start point DC 0,5...8 / end point DC 2,5...10
Setting emergency position [%]	Actuator spindle 0...100 , adjustable (POP-rotary button)
Bridging time (PF) variable[s]	1...10
Position accuracy [%]	5 absolute
Manual override	Gear disengagement with push-button
Nominal stroke [mm]	20
Actuating time [s/mm]	150/20
Actuating time emergency control function [s/mm]	35/20
Override control MAX (max. position) [%]	100
Override control MIN (min. position) [%]	0
Override control ZS (intermediate position only AC) [%]	50
Override control ZS variable	ZS= MIN ...MAX
Sound power level motor max. [dB(A)]	55
Sound power level motor note [dB(A)]	55 bei 90s Laufzeit
Sound power level emergency control function [dB(A)]	60
Position indication [mm Hub]	mechanically 5...20
Safety	
Protection class IEC/EN	III Safety extra-low voltage
Degree of protection IEC/EN	IP54
EMV	CE according to 2004/108/EG
Certification IEC/EN	tested according to: IEC/EN 60730-1 und IEC/EN 60730-2-14
Mode of operation	Type 1.AA
Rated surge voltage supply/control [kV]	0,8
Pollution degree of the environment	3
Ambient temperature [°C]	0...50
Storage temperature [°C]	- 40...80
Ambient humidity [% RH]	Max. 95, not condensing